



WOODMASTER **FIREMAX**

DUAL FUEL READY
OUTDOOR COAL FURNACES

OWNER'S MANUAL



FIREMAX 5000
TITANIUM SERIES

FIREMAX 6000
TITANIUM SERIES

WARNING: If the information in this manual is not followed exactly, a fire or explosion may result causing property damage, personal injury or loss of life.

- Do not store or use gasoline or other flammable vapors and liquids in the vicinity of this or any other appliance.
- **WHAT TO DO IF YOU SMELL GAS**
 - Do not try to light any appliance.
 - Do not touch any electrical switch.
 - Immediately call your gas supplier. Follow the supplier's instructions.
 - If you cannot reach your gas supplier, call the fire department.
- Installation and service must be performed by a qualified installer, service agency or the gas supplier.



0117WH046S

The use of wood in this furnace, except for coal ignition purposes, is prohibited by law in the U.S.

SAVE THESE INSTRUCTIONS

p/n 9001256 - REV. B



WoodMaster, Inc. • 20502 160th Street • Greenbush, MN 56726 • WoodMaster.com

WoodMaster FireMax Titanium models 5000 and 6000 outdoor hydronic heaters by WoodMaster are listed by OMNI-Test Laboratories to the following standards: UL 2523 "Solid Fuel-Fired Hydronic Heating Appliances, Water Heaters, and Boilers" (ANSI/UL 2523-2018); CSA B366.1-11 "Solid fuel-fired central heating appliances"; ANSI Z21.13-2017 • CSA 4.9-2017 "Gas-fired low pressure steam and hot water boilers"; UL 726 "Oil-Fire Boiler Assemblies"; CSA B140.3-1962 (R2020) "Oil burning stoves and water heaters"; Also certified to add to an existing heating system.

FIREMAX 5000 – Water Capacity: 171 gal. (647 liters) – Weight: est. 1,300 lbs (590 kg)
FIREMAX 6000 – Water Capacity: 350 gal. (1,325 liters) – Weight: est. 2,000 lbs (907 kg)

French Owner's Manual and decal set available upon request from your dealer.
(Manuel d'installation en français et décalcomanies disponible sur demande auprès de votre revendeur)

- Register at time of purchase for 25 Year Limited Warranty -

Verify your warranty and check status of water samples at: WoodMaster.com/w25

For parts and accessories, service or repairs, call your authorized WoodMaster dealer or heating contractor. Record the information below for future reference.

Model	Serial Number	Installation Date
Dealership Name		Phone Number
Owner Name		

Contents

WoodMaster Online Resources	Iv
Labeling and Terminology	1
Important Precautionary Information	2
Foundation	4
Access to Ports on Outdoor Furnace	5
Ground Rod Kit	7
Furnace Installation - Connecting to Your Existing System	7
Outdoor Furnace Best Burn Practices	9
Chimney Recommendations	9
Chimney Installation	9
WATER QUALITY AND MAINTENANCE	12
1. Test Supply Water	12
2. Check the Vent Cap	12
3. Check Heating System for Leaks	12
4. Cover Supply and Return Lines	13
5. Add MolyArmor through Vent Pipe	13
6. Fill Outdoor Furnace with Water and Purge Air	13
7. Immediately Start the Pump(s); then Heat the System Water to 185°F (85°C) ..	14
8. Test the Treated System Water	15
Send in Initial Water Sample	16
Initial Water Sample	16
Deferred Installation	16
Check Status of Water Sample	16
Annual Water Sample	16
System Maintenance	17
Water Test Kits and Test Results	17
Flushing the System	19
Adding Antifreeze to Outdoor Furnace System	20
Coal Selection and Characteristics	21
Starting and Maintaining a Coal Fire	21
Operating Efficiency Tips	21
Operating Instructions	22
Adjusting Water Temperature	22
Initial Fire Up - Start of Heating Season	23
Modes of Operation	24
Operating Optional Burner	25
Filling the Firebox	26
Adding Heat Load	27
Electronic Temperature Controller	28
Electric Controller Reference	29
Changing Settings	34
Maintenance Schedule	35
Control Locations	36
Routine Maintenance	36
Maintenance Sections	37
Serviceable Items	41
Firebox Door Cam Loc Adjustment	41
Firebox Door Seal Rope	42
Ash Removal Door Seal	43
Light Bulb	44
Temperature Controller	44
Water Temperature Sensor	45
Replacing Swinging Baffles	46
Troubleshooting	47
General Information	50
Furnace Measurements	51
Wiring Diagrams	52
Water Sample Information - Titanium Series Models	53

How to Use This Guide

The guide is divided into sections to help with the operation and maintenance of the outdoor furnace. If questions arise that are not answered with this manual, consult with your authorized WoodMaster dealer.

WOODMASTER ONLINE RESOURCES

Enter **WoodMaster.com** in your browser or scan the code using any QR code reader app on your smartphone to access WoodMaster's library of information to help with installation, operation and maintenance of your WoodMaster outdoor furnace.

Detailed Furnace Installation Variations - <https://www.woodmaster.com/furnace-installation/>

View and/or download PDFs to assist in installation of your outdoor furnace. Information and examples regarding pumps, foundations, chimneys and support structures, ThermoPEX piping, and example configurations for a variety of heating configurations.



Online Support Center

<https://support.woodmaster.com>

Enter your furnace serial number and find articles, answers, parts and more information.



Online Support Center

[support.WoodMaster.com](https://support.woodmaster.com)
Enter your serial number for information specific to your furnace.

Write your *serial number* here for future reference.



Videos to supplement the Owner's Manual are available at www.youtube.com/@Wmfurnaces
Watch tips on initial startup, testing system water and more.

INSTALLATIONS IN MASSACHUSETTS:

1. All installation components must be products approved in the Commonwealth of Massachusetts by the Gas and Plumbing Board.
2. The maximum run of tubing from the water heater to a fan coil is 50 linear feet.
3. Persons operating this hydronic heater are responsible for operation of the hydronic heater so as not to cause a condition of air pollution as defined in 310 CMR 7.01(1).

Labeling and Terminology

The outdoor furnace and this guide use the following terms and symbols to bring attention to the presence of hazards of various risk levels and important information concerning the use and maintenance of the outdoor furnace.

DANGER

This symbol and text indicate an imminently hazardous situation which, if ignored, will result in death or serious injury.

WARNING

This symbol and text indicate the presence of a hazard which can cause severe personal injury or death to an operator or bystander, or substantial property damage if ignored.

CAUTION

This symbol and text indicate the presence of a hazard which can cause minor personal injury or property damage if ignored.

NOTE: Indicates supplementary information worthy of particular attention relating to installation, operation, or maintenance of the outdoor furnace but is not related to a hazardous condition.

Be sure to follow all instructions and related precautions as they are meant for your safety and protection. Store this manual in a readily accessible location for future reference.

Important Precautionary Information

Be sure to read carefully and understand these precautions before, during and after the installation, operation and maintenance of the furnace.

NOTE: All operations must be in accordance with local and state codes which may differ from the information in this manual.

⚠ CAUTION

This outdoor furnace is not intended to be the only source of heat. In the event of a prolonged power failure, a generator may be used to prevent lines from freezing. Should the outdoor furnace be left unattended, run out of fuel or require service, an alternate heating source in the building being heated should be in place to prevent damage caused by freezing.

⚠ WARNING

This outdoor furnace and/or chimney is not intended or safety tested to be used or installed in a building where contents of that building could be damaged or where a financial loss could occur from smoke, soot, fire or water.

⚠ WARNING

The outdoor furnace vent cap must fit loosely on the vent opening. Do not force the cap down or try to seal it tightly onto the vent pipe. Do not extend or restrict the vent pipe or opening. **DO NOT ALLOW THE OUTDOOR FURNACE TO BE PRESSURIZED.**



⚠ WARNING

Be sure the outdoor furnace is filled with water before firing. Never fire the outdoor furnace when the water level is more than 1" (2.5 cm) below the FULL mark on the sight gauge. MolyArmor 350 must be added before the initial fill (see Water Quality and Maintenance).

⚠ WARNING

Disconnect the electrical power to the outdoor furnace before replacing an electrical component.

⚠ WARNING

Do not attempt service inside the electrical control panel without first disconnecting the electrical power at the main power source.

NOTE: Any electrical installation should be done by a qualified installer in accordance with applicable codes.

⚠ WARNING

Allow the outdoor furnace to thoroughly cool and completely clean out the firebox before draining water from the outdoor furnace. If the water in the outdoor furnace ever boils, be sure to check the water level and restore to full. If water is added, the proper level of MolyArmor 350 Corrosion Inhibitor (p/n 2900631) must be maintained.

⚠ WARNING

When cleaning the outdoor furnace, be careful not to spill any coals.

⚠ WARNING

ALWAYS store ash in a covered non-combustible container.

⚠ WARNING

⚠ WARNING

Maintain the following clearances from combustibles for the furnace installation:

- 44" (112 cm) from the back
- 12" (30.5 cm) from the sides
- 48" (122 cm) from the front
- 18" (46 cm) from chimney inspection cover
- The foundation must be noncombustible

⚠ WARNING

Do not allow combustible materials (straw, hay or wood) near the outdoor furnace. Keep the perimeter of the outdoor furnace clear and clean.

⚠ WARNING

For fire safety, keep all combustible materials at least six feet (two meters) away from the outdoor furnace, especially around the door area. Debris of wood chips and other combustibles in the area may be easily ignited if a hot coal is spilled out of the firebox and left unnoticed.

⚠ WARNING

The firebox door must be closed and latched at all times except when filling the firebox. Leaving the firebox door open may lead to a runaway fire. In the event of a runaway fire, close the firebox door. In the event of a chimney or soot fire, close the firebox door and make sure power is off to the outdoor furnace.

⚠ WARNING

The ash removal door must be closed and secured at all times except when removing ash or a runaway fire may result. The ash removal door should never be opened when the outdoor furnace is in idle or standby mode. Combustible gases can collect and ignite when exposed to air, causing a flashback.

⚠ WARNING

All covers must be maintained at all times except during maintenance, inspection and service.

NOTE: Do not use chemicals or fluids to start the fire. Use kindling or a small amount of paper to start an initial fire.

NOTE: The sight gauge valve should always be closed, except when checking water level. Water will automatically drain from the sight gauge tube when the valve is closed. Remember that this type of valve requires only 1/4 turn to open or close.

⚠ WARNING

This heater is designed to burn coal only. Follow all applicable codes and laws.

NOTE: The prohibition against burning these materials does not prohibit the use of fire starters made from paper, cardboard, saw dust, wax and similar substances for the purpose of starting a fire in an affected heater.

NOTE: Chloride or sulfurous gases can be generated if plastic or rubber is burned and will mix with moisture and form hydrochloric or sulfuric acids in the firebox, creating corrosion.

NOTE: This outdoor furnace is not to be used with an automatic stoker.

⚠ CAUTION

This outdoor furnace is not to be connected to a chimney flue serving another appliance.

NOTE: At least one circulation pump must run continuously to ensure proper operation of the outdoor furnace.

NOTE: A 40-watt appliance light bulb is recommended if replacement is necessary. Do not install a bulb in excess of 60 watts.

NOTE: In case of a power outage, either a generator or 12V battery with a power inverter can be used to provide electricity to operate the outdoor furnace.

Foundation

The outdoor furnace may be installed directly on stable, level ground without the necessity of a foundation, although installing the outdoor furnace on a foundation offers many advantages. The outdoor furnace is less likely to move due to frost heaving. A foundation keeps the area directly around the outdoor furnace free of standing water and can help to keep unwanted pests out. It can also raise the furnace up to provide a more comfortable height of the firebox door opening.

If the ground is unstable, one option is to use patio blocks under the perimeter of the base. Another option is to pour a concrete foundation.

To install the outdoor furnace on a concrete foundation, refer to the illustration for dimensions and for the location of the hollowed-out area for each model. A 4" to 6" (10 to 15 cm) thick concrete slab works well; however, a thicker slab may be used to obtain the desired door opening height.

If the area for the concrete slab is unstable and/or affected by frost heaving, consider installing 2" closed-cell insulation beneath the front portion of the slab and under the area of the ground used for walking.

⚠ CAUTION

Do not use any combustible materials for the foundation.

NOTE: The installation surface or foundation must be noncombustible. The hot supply and return lines must also be protected from possible exposure to sunlight, fire or physical damage that may be caused by an occurrence outside the outdoor furnace enclosure. Foundations may consist of concrete, crushed rock or patio blocks.

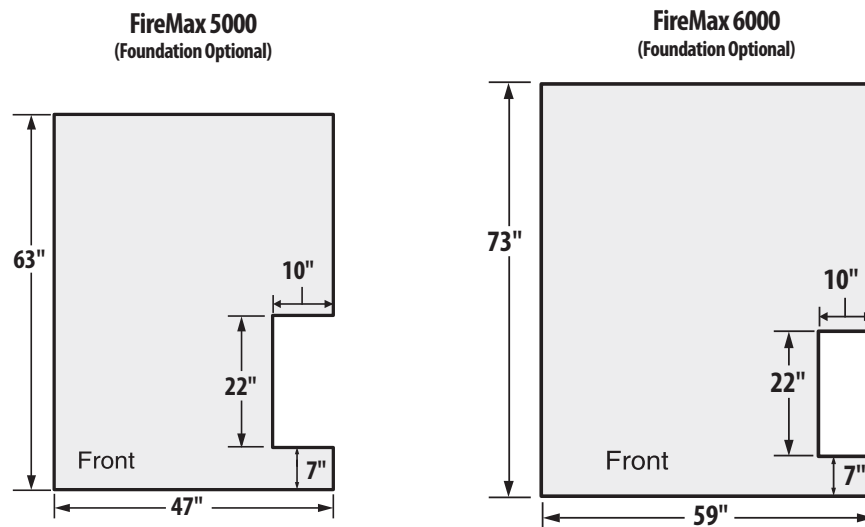

⚠ CAUTION

Do not use any combustible materials for the foundation.

Outdoor furnace must be installed on a noncombustible surface or foundation that incorporates an enclosure that will prevent supply and return lines from possible exposure to sunlight, fire, or physical damage that may be caused by an occurrence outside the outdoor furnace enclosure. Foundation may consist of concrete, crushed rock, or patio blocks.

Access to Ports on Outdoor Furnace

Ports are provided that allow mounting circulation pumps on the outdoor furnace. Refer to the illustrations in this section for proper supply and return line and pump installations for your model.

NOTE: The Installation Guide provides more information on pump selection. For even more detailed information, see the Hydronic Component Selection Guide (p/n 2482), available from your WoodMaster dealer.

NOTE: At least one circulation pump must run continuously to ensure proper operation of the outdoor furnace.

FireMax 5000 – 1-Pump Configuration

1 - Pump Parts List*		
Qty	p/n	Description
1	5800055	Circulator Pump, 20-58
1	5800019	Pump Flange Kit, 1-1/4"
1	409	Nipple, 1-1/4" x Close
1	5000898	Ball Valve, Brass, 1-1/4"
2	1324	PEX Adapter, 1"
2	5926	PEX Clamp Crimp Ring, 1"
2	5000978	Reducer, 1-1/4" x 1"
1	0020-250	Nipple, 1" x 2"
1	0020-403	Swing Check Valve, 1"
-	5700082	1" Central PEX Tube

*Additional suggested plumbing components. Circled fittings (shown in side views) are included with furnace.

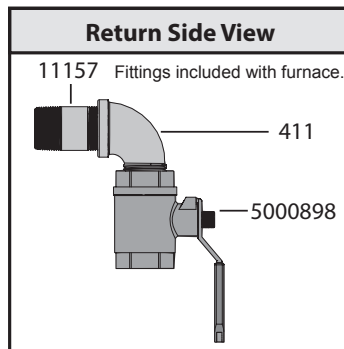
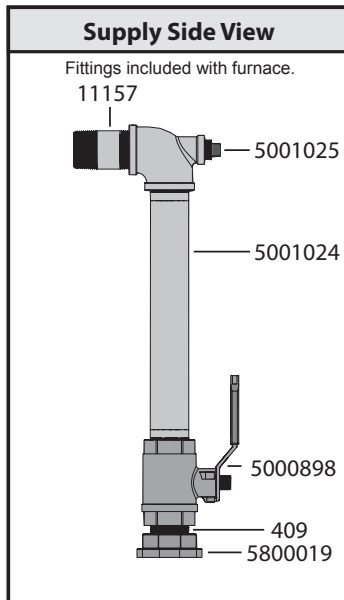

For illustration purposes only.

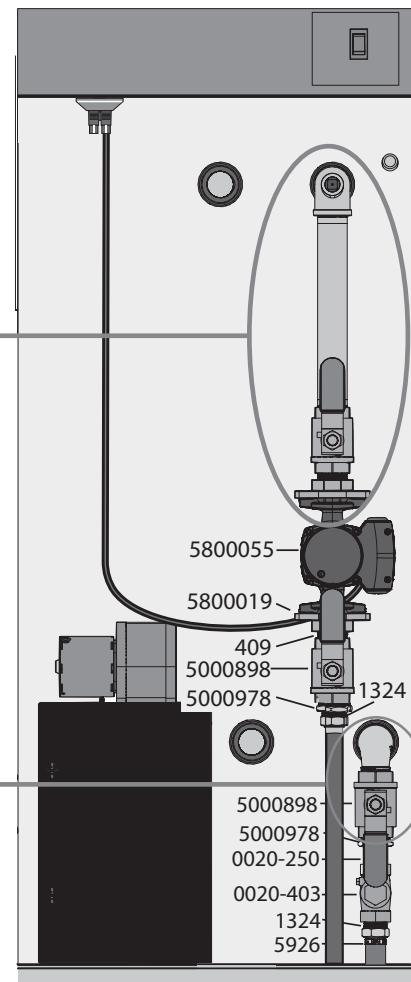

FireMax 6000 – 2-Pump Configuration

1 - Pump Parts List*		
Qty	p/n	Description
2	5800055	Circulator Pump, 20-58
2	5800019	Pump Flange Kit, 1-1/4"
2	409	Nipple, 1-1/4" x Close
2	5000898	Ball Valve, Brass, 1-1/4"
4	1324	PEX Adapter, 1"
4	5926	PEX Clamp Crimp Ring, 1"
4	5000978	Reducer, 1-1/4" x 1"
2	11157	Nipple, 1-1/4" x 3"
1	411	Street Elbow, 90°, 1-1/4"
1	5001025	Reducing Tee, 1-1/4" x 1/2"
1	5001024	Nipple, 1-1/4" x 12"
2	0020-250	Nipple, 1" x 2"
2	0020-403	Swing Check Valve, 1"
-	5700082	1" Central PEX Tube

*Additional suggested plumbing components. Circled fittings (shown in side views) are included with furnace.

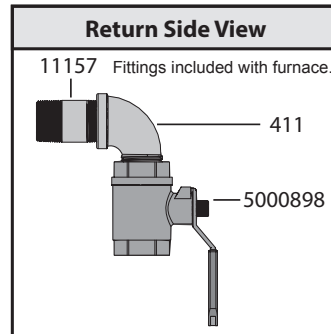
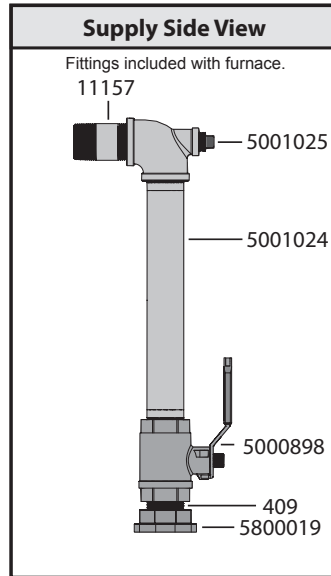

For illustration purposes only.

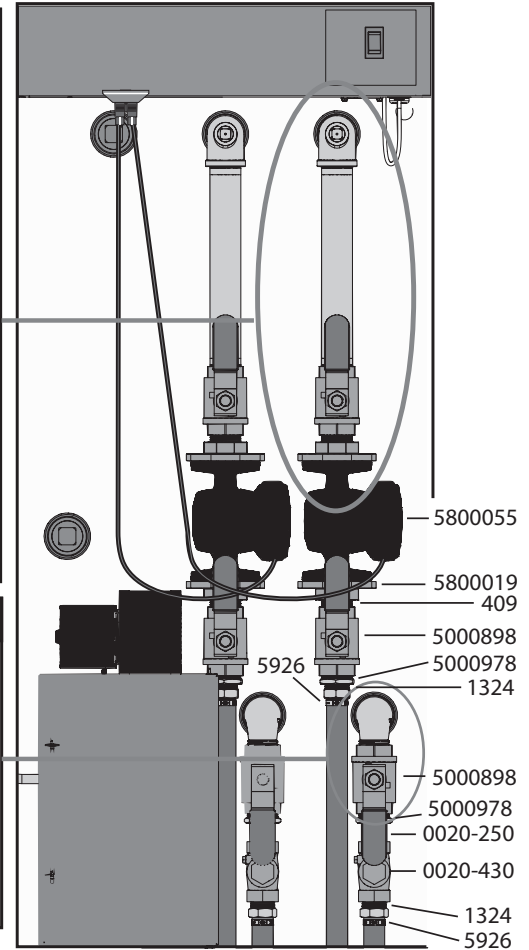

Ground Rod Kit

The outdoor furnace must be electrically bonded to ground in accordance with the requirements of the authority having jurisdiction or, in absence of such requirements, with the National Electrical Code, ANSI/NFPA 70 and/or the Canadian Electrical Code Part 1, CSA C22.1 Electrical Code.

Install a Ground Rod Kit (p/n 6593) and connect it to the outdoor furnace.

1. In the water line trench near the outdoor furnace, drive the ground rod into the ground until the top of the ground rod is below the ground surface.
2. Route the ground wire from the ground rod under the outdoor furnace base and over to the frame of the outdoor furnace.
3. Secure the ground terminal with a cap screw (1/4" x 3/4"), star washer and nut. Secure the ground wire to the terminal; then secure the ground wire to the ground rod with the clamp. Tighten all hardware securely.

NOTE: A hole for the ground terminal has been pre-punched in the outdoor furnace base near the pumps.

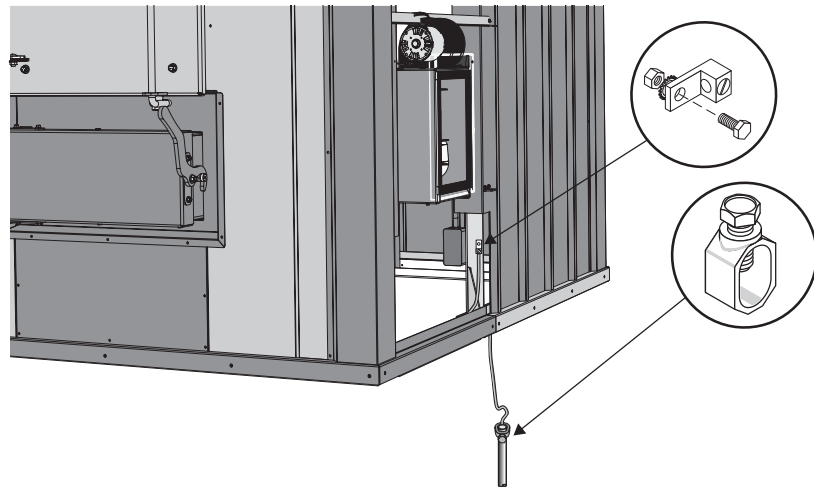

Furnace Installation - Connecting to Your Existing System

A common installation is to connect the outdoor furnace to an existing water heater and then to an existing forced air system. A water-to-air heat exchanger is mounted in the plenum or duct work of the existing furnace. Heated water from the outdoor furnace either continuously flows through the water-to-air heat exchanger or is diverted through a 3-way zone valve. When the thermostat senses the need for heat, the fan on the existing furnace forces air through the heat exchanger, transferring heat throughout the existing ductwork.

NOTE: There are numerous ways to connect to your heating system. Refer to the Outdoor Furnace Installation Guide for other installations.

Detailed Furnace Installation Variations

Visit WoodMaster.com to access a library of detailed illustrations for connecting to a wide variety of existing heating systems and for other heating options.

Typical Installation Connecting to Water Heater and Forced Air Furnace

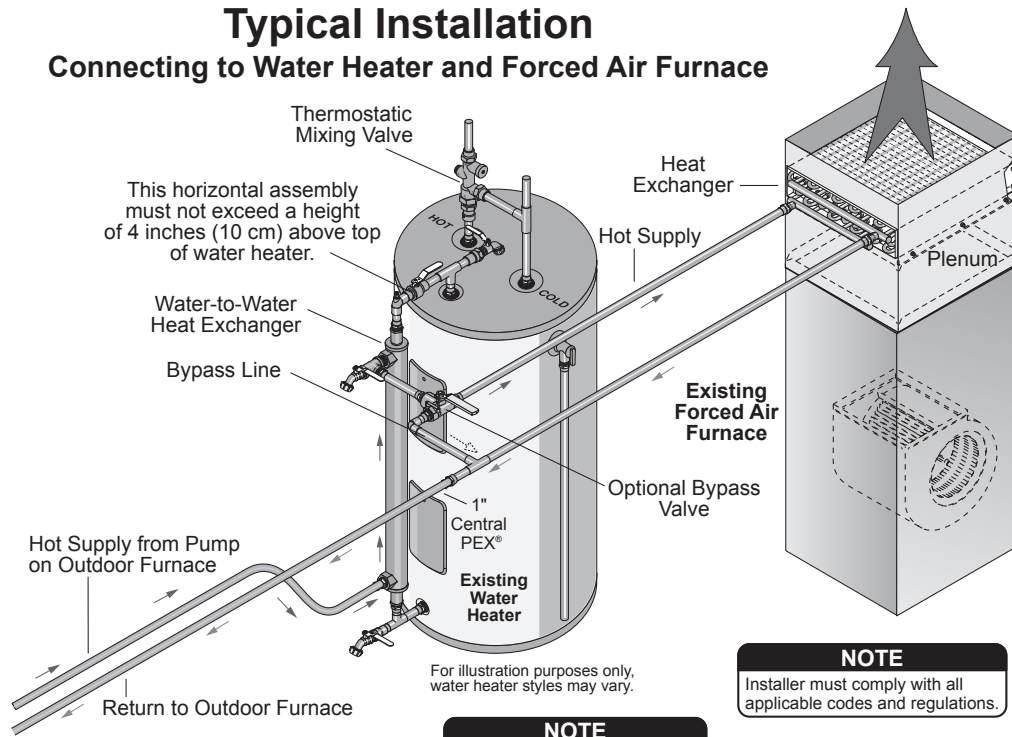

NOTE: A certified electrician must do the electrical installation.

NOTE
Any electrical installation should be done by a qualified installer in accordance with applicable codes.

NOTE
Installer must comply with all applicable codes and regulations.

For illustration purposes only, water heater styles may vary.

Remote Thermal Storage Installation Connecting to Remote Thermal Storage Tank

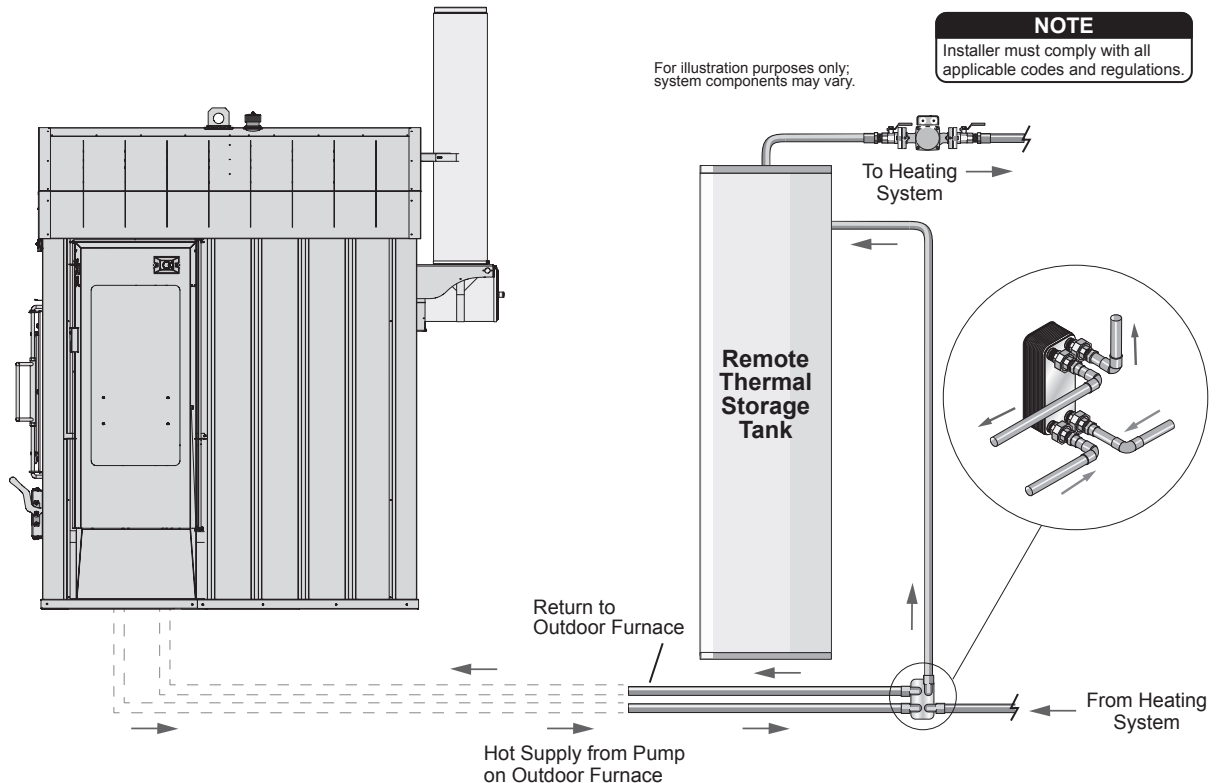

NOTE
Installer must comply with all applicable codes and regulations.

For illustration purposes only; system components may vary.

Outdoor Furnace Best Burn Practices

1. Read and follow all operating instructions supplied by the manufacturer.
2. FUEL USED: Only those listed fuels recommended by the manufacturer of your unit. Never use the following: trash, plastics, gasoline, rubber, naphtha, household garbage, material treated with petroleum products (particle board, railroad ties and pressure treated wood), leaves, paper products, and cardboard.
3. LOADING FUEL: For a more efficient burn, pay careful attention to loading times and amounts. Follow the manufacturer's written instructions for recommended loading times and amounts.
4. STARTERS: Do not use lighter fluids, gasoline, or chemicals.
5. CHIMNEY RECOMMENDATIONS: In higher populated areas, extend the chimney to a height above the roofs of surrounding buildings.
6. Always remember to comply with all applicable state and local codes.

Be considerate of neighbors when operating your furnace. If you use your furnace in the summer months, be certain your chimney exhaust is not adversely affecting neighbors with open windows.

Chimney Recommendations

In higher populated areas, extend the chimney to a height above the roofs of surrounding buildings. Use WoodMaster Chimney Extensions when extending the chimney. When eight feet (2.4 m), or two sections of chimney are used, the sections must be secured at the connection joint with four (4) screws to stabilize the extension.

Chimney Installation

NOTE: Instructions for installing chimney sections and the chimney brace assembly are also provided with the furnace.

1. Remove the two Slotted Hex Screws (p/n 4283) securing the Shipping Plate to the Chimney Brace Assembly.
2. Discard the Shipping Plate and remove the three Self-Tapping Screws (p/n 4278) from the slot in the chimney brace assembly. These screws are used to assemble the chimney sections.
3. Assemble the Chimney Brace Slide (p/n 10854-011) to the Chimney Rafter Brace (p/n 10853-011) with the two Slotted Hex Screws removed in step 1. Do not tighten the screws.
4. Remove the single Slotted Hex Screw securing the Chimney Strap (p/n 10792) to the Chimney Brace Slide.
5. Assemble the chimney as shown.
6. Push the chimney against the Chimney Brace Slide; then wrap the Chimney Strap (p/n 10792) around the chimney and secure with the Slotted Hex Screw.
7. Level the chimney front to back; then tighten the screws on the Chimney Brace Slide.
8. Secure the base of the chimney with three Self-Tapping Screws (p/n 4278).

If more than eight feet (2.4 m) of chimney are added, the chimney should be reinforced appropriately. The illustration shows chimney support recommendations when three or more sections are used. When adding sections of chimney, make sure that there is nothing within the fall zone of the chimney that could be damaged. If something is located within the fall zone and cannot be removed, guy wires or braces may need to be installed to prevent a falling chimney from causing damage.

NOTE: If more than three 4-foot (1.2-m) sections of chimney are used, a support (e.g., a pole, pipe or other structural support) may be installed from the ground that can withstand wind. Other reinforcement recommendations are shown.

NOTE: For chimney extensions or chimney replacement, use only genuine WoodMaster chimney components. Parts are available from an authorized WoodMaster dealer.

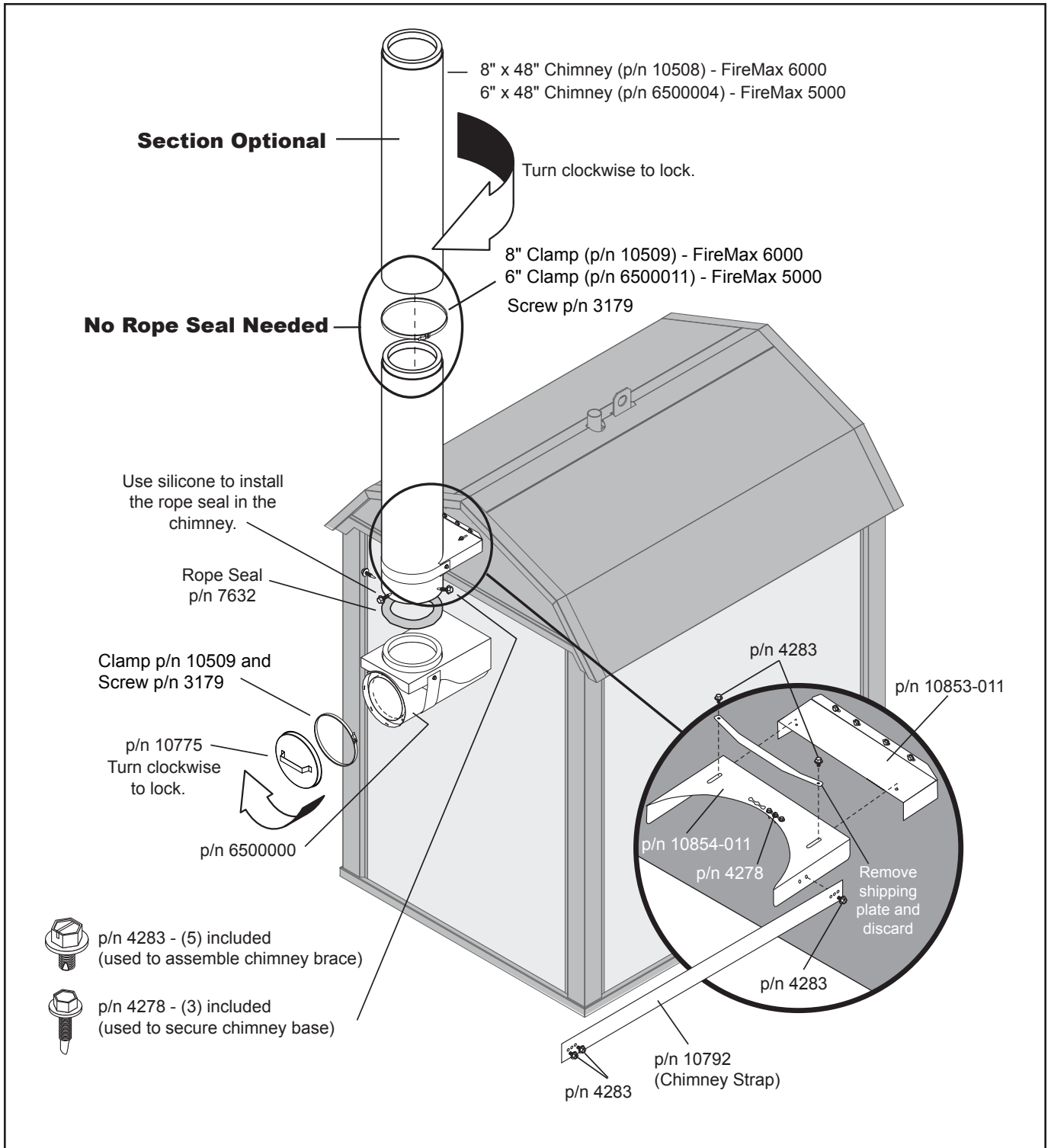

The installation of a spark arrestor is recommended, particularly where there are dry conditions or where there is combustible material near the unit, unless the installation of a spark arrestor is prohibited by local requirements.

NOTE: If the screen is left on the chimney cap, the spark arrestor should be inspected and cleaned as needed.

Use common sense to avoid potential fires, including exercising caution when disposing of ashes, cleaning and refueling. Keep all highly combustible materials (e.g., gasoline, propane, leaves, pine needles, etc.) away from an operating unit at all times. Take special precautions in windy conditions.

NOTE: You may need to increase the chimney height if conditions occur that force exhaust to low levels.

Chimney Reinforcement Recommendations

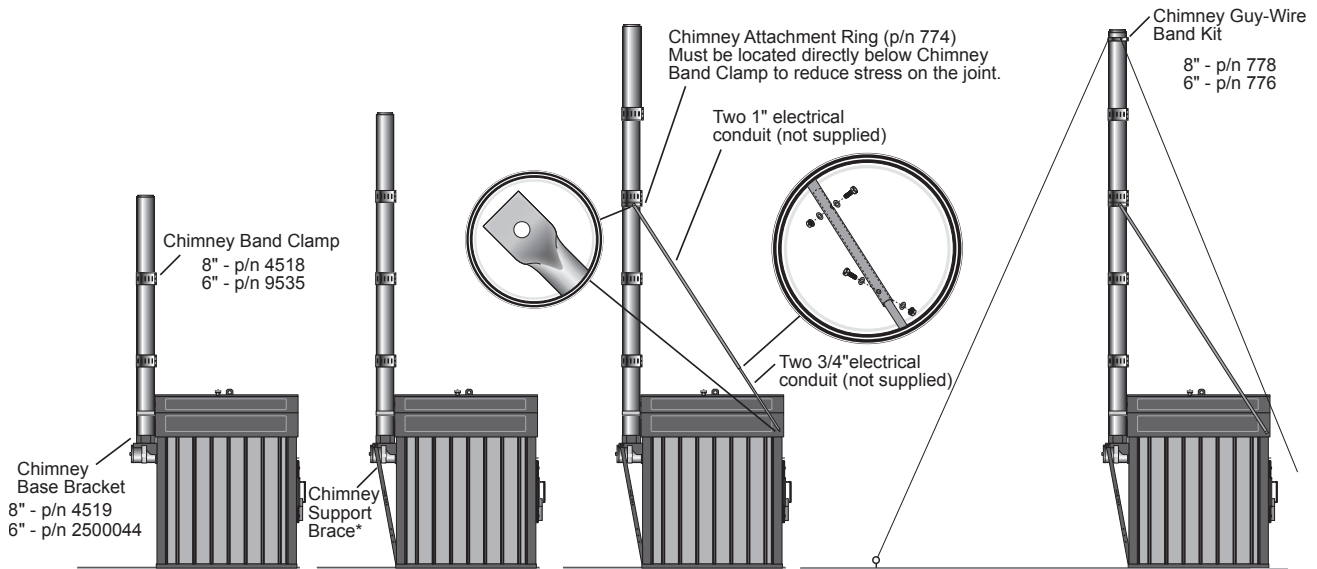

Three Sections
When three sections of chimney are being used a Chimney Band Clamp Kit for each joint and a Chimney Base Bracket Kit are recommended.

Four Sections
When four sections of chimney are being used a Chimney Band Clamp Kit for each joint, a Chimney Base Bracket Kit and a Chimney Support Brace Kit* are recommended.

Five or More Sections
When five or more sections of chimney are being used a Chimney Band Clamp Kit for each joint, a Chimney Base Bracket Kit, a Chimney Support Brace Kit and a Chimney Attachment Ring (p/n 774) are recommended.

Fall Zone
If objects are placed in the fall zone of the chimney, a Chimney Guy-Wire Band Kit or additional bracing is recommended.

*Chimney Support Brace Chart	
p/n	Models
4554	ALL

NOTE

- Additional bracing may be necessary in certain areas such as those subject to severe weather, winds, freezing rain, etc.
- Inspect all bracing bi-annually for integrity.

WATER QUALITY AND MAINTENANCE

Follow the steps provided here to add MolyArmor 350 and to fill the outdoor furnace system for the first time, or any time the system has been completely drained and needs to be refilled.

Before you fire the outdoor furnace for the first time, it is very important to perform the following important steps in order.

1. Test Supply Water

Test a sample of the supply water (makeup water) that will be used to fill the outdoor furnace (softened water is recommended). Test strips for testing pH are included in the water test kit which is provided with the outdoor furnace.

1. Collect a small sample of the water to be used to fill the outdoor furnace in a clean container.
2. Dip a test strip from the test kit in the water sample for **1 second** and remove. Shake off excess liquid (very important to prevent water bleed from one pad to the other). Compare the pH test pad to the color chart at **30 seconds**.
3. If the pH level is between 6.5 and 8.0 and there are no other known water quality problems, then the outdoor furnace may be filled with this water.
4. Water that has a pH level of less than 6.5 or greater than 8.0, or that has other known water quality problems, should not be used to fill the furnace. Instead, water should be supplied from a different source.

2. Check the Vent Cap

If the vent cap has been secured with a wire tie-down, the wire tie-down **MUST** be removed before operating the furnace. If the vent cap is held in place by a spring retainer, the spring retainer can be left in place. The vent cap must fit loosely over the outdoor furnace vent.

3. Check Heating System for Leaks

Close the valves on the outdoor furnace before checking the heating system for leaks.

CAUTION

Do not pressurize the outdoor furnace or damage could occur. Isolate the furnace when pressure testing by closing all of the valves on the outdoor furnace.

Pressure-test the entire plumbing heating system. Apply 50 psi (3.5 kg/cm²) of air pressure for thirty minutes and closely monitor for any pressure loss. Inspect all fittings and hose ends for any signs of leakage using leak detection solution (leak soap); repair as necessary.

Release the pressure from the entire plumbing heating system and open the valves on the outdoor furnace.

4. Cover Supply and Return Lines

Backfill the trench for the supply and return lines. Enclose the area where the supply and return lines enter the outdoor furnace. Do not leave the PEX hot supply and return lines exposed to sunlight as exposure to UV rays will damage them.

5. Add MolyArmor through Vent Pipe

CAUTION

Avoid damaging your furnace and voiding your warranty. Add water treatment BEFORE adding water to the system. Water treatment in your outdoor furnace is just as important as the oil in a car's engine.

MolyArmor 350 Corrosion Inhibitor (p/n 2900631) gives optimum protection for the furnace water jacket and system parts when it is used to initially treat the water and is maintained at a minimum of 350 ppm of moly and pH level between 8.0 and 9.5.

NOTE: The recommended minimal treatment amounts are based on an average heating system with less than 50 feet of ThermoPEX, one heat exchanger in a forced-air furnace and a heat exchanger on a domestic water heater.

NOTE: If the system has a larger than normal water capacity, more MolyArmor 350 should be added at a recommended rate of 6.5 oz. (190 ml) per 10 gallons (37.8 liters) of system water. One gallon (3.78 liters) of MolyArmor 350 Corrosion Inhibitor will treat 200 gallons (757 liters) of system water.

MOLYARMOR 350 MINIMAL TREATMENT AMOUNTS	
FireMax 6000	2.5 gallons
FireMax 5000	1.5 gallons

1. Add the recommended amount of MolyArmor 350 Corrosion Inhibitor (or more depending on the water capacity of the heating system) through the vent pipe on the outdoor furnace.

NOTE: Be sure to add enough MolyArmor 350 to obtain at least 350 ppm moly. There are no negative effects from adding more than the recommended amount of MolyArmor 350.

6. Fill Outdoor Furnace with Water and Purge Air

NOTE: If adding antifreeze to the system, refer to Adding Antifreeze to Outdoor Furnace System section for important information.

⚠ CAUTION

If using antifreeze, use **ONLY** uninhibited, undyed, "raw" propylene glycol industrial grade with softened water and add the correct amount of MolyArmor 350 to achieve 350 ppm moly and 8.0 to 9.5 pH levels. Some distributors call this type of antifreeze PGI (shorthand for Propylene Glycol Industrial grade).

NOTE: If the outdoor furnace is being filled with water when the temperature is below freezing, circulate the water immediately after filling to prevent freezing the water lines.

NOTE: The circulation pump(s) must be installed in the hot supply line(s).

NOTE: All air must be purged from the water lines when filling the system. Be sure to purge the air from each pump circuit from the outdoor furnace.

NOTE: All valves in the outdoor furnace system should be opened before starting this procedure.

1. Connect a garden hose to the water source to be used to fill the outdoor furnace. Purge the garden hose of any impurities by running water through it until the water is clear.
2. Connect the hose to the drain valve on the outdoor furnace. Open the drain valve and fill with water to thoroughly mix the MolyArmor 350, which is heavier than water.

7. Immediately Start the Pump(s); then Heat the System Water to 185°F (85°C)

⚠ CAUTION

Be sure the outdoor furnace is filled with water before firing. Never fire the outdoor furnace when the water level is more than 1" (2.5 cm) below the FULL mark on the sight gauge.

NOTE: The sight gauge valve should always be closed except when checking water level. Water will automatically drain from the sight gauge tube. Remember that this type of valve requires only 1/4 turn to open or close.

1. Start the pump(s). Refer to Initial Fire Up - Start of Heating Season in the Owner's Manual to start the outdoor furnace. Bring the water temperature up to operating temperature (185°F or 85°C) for 24 hours with the system circulating; then add water to the full mark. Continue to run the pump and circulate the water for 24 hours. If a multi-speed pump is used, set the pump on high.

NOTE: It is important to bring the water in the system up to operating temperature (i.e., 185°F or 85°C) immediately after filling the system and to circulate for at least 24 hours to kill bacteria. This also applies any time water is added to the system.

⚠ CAUTION

The water in the system may be hot. Use caution and the appropriate personal protective equipment (PPE) when checking for leaks.

2. Check the system for leaks. Inspect all fittings and hose ends for any signs of leakage.

NOTE: After a week of operating, use the procedure in step 2 to check the system for leaks again.

NOTE: If water is ever added, it is important to bring the water in the system up to operating temperature (i.e., 185°F or 85°C) immediately. Refer to Water Quality and Maintenance in the Owner's Manual for water testing procedures. If indicated by test results, add MolyArmor 350 as required. Deterioration due to improper operation and/or maintenance is not covered by warranty.

8. Test the Treated System Water

After circulating the heated water in the system for 24 hours, test the treated system water for the recommended moly (at least 350 ppm) and pH level (between 8.0 and 9.5).

CAUTION

The water in the sight gauge may be hot. Use caution when obtaining a sample.

1. To obtain a system water sample, bend the sight gauge tube away from the outdoor furnace. Before collecting the sample, open the valve and drain about a quart of water from the sight gauge tube; then carefully fill the sample container without contaminating the sample. **Be sure to properly install the sight gauge tube and close the valve when finished.** The water in the sight gauge valve and tube will drain when the valve is closed.
2. Dip a test strip from the test kit in the water sample for **1 second** and remove. Shake off excess liquid (very important to prevent water bleed from one pad to the other). Compare moly test pad to the color chart within 10 seconds. The moly level must be **350 ppm or more**.
3. Compare pH test pad to the color chart at **30 seconds**. The pH of the treated water should be **between 8.0 and 9.5**. If the pH is higher than 10.0, dilute the water in the furnace by draining approximately 1/4 of the water from the furnace. Add MolyArmor 350 and refill with water that has a pH between 6.5 and 8.0. After refilling, circulate the water with furnace at operating temperature for at least 24 hours and test to confirm the moly is **350 ppm or more and the pH is between 8.0 and 9.5**.

Send in Initial Water Sample

NOTE: It is your responsibility as owner to ensure that your water sample information is accurate and that you submit your samples on a timely basis as required by the warranty for your stainless steel outdoor furnace. Failure to do so will result in a one year warranty.

Your owner's packet contains a Water Sample Kit for submitting an initial water test and an informational sheet entitled Submitting Water Samples for Your Titanium Series Outdoor Furnace. Follow the instructions to collect and submit your initial water sample. Additional Water Samples Kits are available from your WoodMaster dealer.

NOTE: Your water sample will be tested and must indicate acceptable levels of water treatment to qualify for the 25 year warranty.

Initial Water Sample

You are required to submit an initial water sample within 30 days of purchase of your outdoor furnace.

Deferred Installation

If your outdoor furnace is not being installed within 30 days of purchase, you must email service@woodmaster.com with your name and your furnace serial number. When the furnace installation is complete, send the water sample **within 10 days of the initial fill**.

Check Status of Water Sample

If you have provided an email address, you will receive an email with the results of your water test.

If you did not provide an email address, you will be notified by mail **ONLY** if your water sample test is **NOT ACCEPTABLE**. If your water sample test is acceptable, you will **NOT** be notified with a mailed letter. You can however check the status of your water test online.

Check the status of your water sample at:

WoodMaster.com/w25

You will need your serial number and postal code. Please allow 2-3 weeks for results to be available. For a deferred installation, your status will be available approximately 10 days after you email the deferred installation message.

Annual Water Sample

You are required to submit a water sample yearly prior to the anniversary date of your initial installation. Record the anniversary date below:

DATE OF INSTALLATION

System Maintenance

Maintaining the corrosion inhibitor at a proper level is imperative to preventing corrosion failures. To qualify for the 25 year warranty, you must follow the instructions in the Owner's Manual concerning initial water treatment and maintenance. When the outdoor furnace is initially put into service, and once a year after that, you are required to submit a water sample to confirm proper maintenance and water treatment. No warranty claim can be approved unless the outdoor furnace registration and the acceptable levels of water treatment are on file at WoodMaster.

Test the pH and moly levels after the first three months and every six months thereafter, and after adding water to furnace.

NOTE: If using antifreeze, test the pH and Moly levels once each month. If the bacterial issues occur, the pH will decrease.

Water Test Kits and Test Results

DATE	pH LEVEL	MOLY LEVEL

Record the results of pH and Moly level tests in the table above.
If additional space is needed, record on a separate sheet of paper.

It is very important to keep record of water test results (including the date, pH and Moly level). The pH and Moly test strips and indicator have a shelf life of approximately two years that can affect their accuracy. Test kits should be stored in a dry area at room temperature to obtain maximum accuracy over a longer period of time.

Biological contamination can occur if the furnace is not heated up to 185°F immediately after filling it with inhibitor and water as directed.

NOTE: It should not be necessary to add water to the outdoor furnace more frequently than once every twelve months. If it is more frequent, either there is a leak in the system or the outdoor furnace is boiling because of improper operation or maintenance (see Troubleshooting Section in the Owner's Manual). Be sure to locate and repair the problem immediately. Frequently adding water can cause deterioration in the water jacket. ANY time water is added to the system, it is extremely important to bring the water temperature up to operating temperature (185°F) as soon as possible, even if it is during the off-season. Failure to bring the water in the system up to operating temperature immediately after filling the system can allow bacteria present in the water to multiply and may increase the potential for corrosion in the system.

If the test indicates a significantly lower-than-recommended pH level (below 8.0), add MolyArmor to increase the pH level.

POST HEATING SEASON MAINTENANCE

The water should be left in the outdoor furnace if the outdoor furnace is not being used for an extended period of time.

1. Refer to the Preventive Maintenance Schedule for a list of operations to perform.
2. Shut off the power supply to the outdoor furnace.
3. Place a cover over the chimney to keep rain from entering the outdoor furnace. Clean and oil the chimney flue to the firebox.

Draining Treated System Water

MolyArmor 350 is composed of common materials. Molybdenum compounds characterized as nontoxic in US Public Health Bulletin 293, by the Federal Hazardous Substances Labeling Act, and by the Occupational Safety and Health Act. However, in keeping with good safety and environmental practices, dispose furnace water in accordance with federal, state and local regulation. Unless regulation prohibits, you may drain the outdoor furnace to a home septic system. If doing so, however, be careful not to overflow the septic system.

Do not drain the outdoor furnace in such a manner that the drain water could in any way contact surface water, stream, river, estuary (where a river meets a sea), lake, pond, ocean or other types of waters.

Do not drain to any location within 50 feet (15 meters) of any water well.

Flushing the System

If the system water is brown or orange, it is an indication that the corrosion inhibitor level has not been maintained correctly and corrosion is present in the water jacket. Sludge Conditioner (p/n 166) can be used by circulating the recommended amount through the furnace **for one week** to help clean some of the corrosion from inside the water jacket before flushing, draining and refilling with water and the correct amount of MolyArmor 350.

NOTE: Use one unit of Sludge Conditioner per 200 gallons of system water.

1. De-energize the pump(s) and close the supply and return valves on the outdoor furnace. Remove the inspection panel and insulation covering the drain to gain access to the drain valve. Remove the cap and connect a hose to the drain.
2. Open the drain to drain the system; then flush the top of the firebox and bottom of the water jacket beneath the firebox using a wand placed in the vent.

CAUTION

Completely clean out the firebox before draining water from the outdoor furnace.

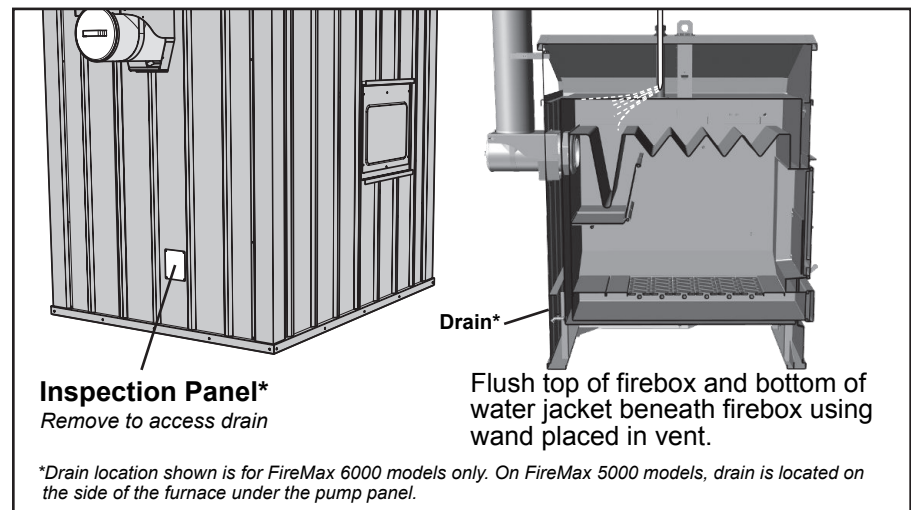

3. Close the drain valve securely and replace the cap on drain after flushing the outdoor furnace.
4. Add recommended amount of MolyArmor 350.
5. Fill the outdoor furnace following the procedure in Finalizing the Installation in the Installation Guide. Start the pump(s) and bring the water temperature up to operating temperature (185°F) for 24 hours with the system circulating to thoroughly mix the MolyArmor 350.

NOTE: ANY time water is added to the system, it is extremely important to bring the water temperature up to operating temperature (185°F) as soon as possible, even if it is during the off-season. Failure to bring the water in the system up to operating temperature immediately after filling the system can allow bacteria present in the water to multiply, which may increase the potential for corrosion in the system.

6. Insulate the area using a mat of fiberglass insulation.
7. Install the inspection panel and secure with self-tapping screws.

Adding Antifreeze to Outdoor Furnace System

If using other antifreeze, use ONLY uninhibited, undyed, "raw" propylene glycol industrial grade with softened water and add the correct amount of MolyArmor 350 to achieve 350 ppm moly and 8.0 to 9.5 pH levels. Some distributors call this type of antifreeze PGI (shorthand for Propylene Glycol Industrial grade).

Most outdoor furnaces are installed **without** antifreeze when an existing heating system is in place and there is no anticipation of leaving the outdoor furnace unattended for extended periods of time (10 days or more). If the building being heated has an alternate heat source, system water may be kept from freezing by running the circulating pump(s) and drawing heat from the existing furnace or boiler in the home or building.

To prevent freezing if the outdoor furnace is not fired for extended time periods or if lengthy power outages are anticipated during cold weather, a nontoxic propylene glycol may be used in the system. Some types of antifreeze that contain various inhibitors have been known to create problems like coagulation and jelling. To prevent potential problems, **do not use propylene glycol that is premixed with inhibitors.** MolyArmor 350 is compatible with (raw) propylene glycol. It is important to use MolyArmor 350 with straight propylene glycol for corrosion protection. If adding antifreeze to the system, it is imperative that the entire system contain **at least 30% antifreeze concentration mixed with water that is 6.5 to 8.0 pH. Softened water is recommended, if available. Do not use reverse osmosis or deionized water that has very low pH.** Bacterial growth is likely to occur with low antifreeze concentrations and can cause corrosion in the furnace water jacket and/or clogging of heat exchangers. To confirm the antifreeze solution is adequate and to kill bacteria, immediately heat the system up to 185° F, allow the pumps to circulate for at least 24 hours and then obtain a sample of the system water. Using an antifreeze tester, the solution must be protected to 10°F (-12°C) or below.

NOTE: If using antifreeze, test the pH and Moly levels once each month. If the bacterial issues occur, the pH will decrease.

NOTE: Be sure to adhere to all warnings and precautions on the antifreeze label.

NOTE: Do not use automotive or RV types of antifreeze.

Before You Start Operating Your FireMax Outdoor Coal Furnace

Be sure to read carefully and observe all of the information in the entire Owner's Manual.

If any questions arise that cannot be answered by the information in this manual, be sure to contact your dealer.

Coal Selection and Characteristics

Coal is a dense, high-energy fuel that provides long burn times and consistent heat output when properly selected and managed. Because coal properties vary by type and source, understanding its characteristics and using correct firing practices are essential for safe, efficient furnace operation.

Coal Characteristics

Coal quality differs depending on where and how it is mined. Factors such as heat value (Btu output), ash content, clinkering tendency and particle size all influence how coal burns. These variations may require adjustments in loading frequency, coal placement or airflow settings. If performance is inconsistent or unsatisfactory after making reasonable adjustments, it may be beneficial to try coal from a different supplier.

Coal smaller than pea size is not recommended, as fine coal may fall through the grates, restrict airflow and negatively affect combustion efficiency. Proper airflow through the fuel bed is critical for maintaining a stable fire.

Starting and Maintaining a Coal Fire

When lighting a coal fire, begin by using a small amount of paper and dry wood kindling to establish an initial fire. This creates the necessary heat to develop a bed of hot embers. Once a sufficient coal bed has formed, add coal gradually until the fire is well established. Avoid adding large amounts of coal at once during startup.

NOTE: Do not load coal above the bottom door frame.

For normal operation, the furnace should typically be loaded twice daily, depending on heat demand and coal type. Smaller, more frequent fuel loads promote hotter and cleaner combustion. This approach helps burn off combustible gases more completely, improving heat transfer to the water jacket and increasing overall system efficiency.

Operating Efficiency Tips

- Avoid filling the firebox to maximum capacity. Don't load coal above the bottom door frame.
- Use moderate fuel loads at regular intervals.
- Maintain proper airflow through the grates and fuel bed.
- Remove ash as required to prevent airflow restriction.

Consistent firing practices and proper coal selection will help achieve dependable performance and longer equipment life.

Operating Instructions

NOTE: These procedures apply to initial firing at the start of the heating season.

CAUTION

Do not burn plastic, garbage, treated wood or fuels not listed for this outdoor furnace.

NOTE: Before firing the outdoor furnace for the first time, make sure the proper amount of MolyArmor 350 has been added and the water level is 1" below the full mark on the sight gauge, as the water will expand when heated.

The temperature controller monitors and controls the water temperature by controlling the actuator and fan. During normal operation (i.e., adequate coal supply), the controller will close the actuator and turn off the fan when the water reaches 185°F (Set). It will open the actuator and turn on the fan when the water falls 2°F (Hy). During shut down (i.e., low coal supply) or when the water temperature falls to 120°F (ALL), the controller will close the actuator and turn off the fan. At this time, the furnace will need to be filled with fuel and the controller will need to be reset (see Initial Fire Up).

Adjusting Water Temperature

The high water temperature setting can be adjusted between 150°F and 195°F.

At 2°F less than the temperature setting (2°F being the thermostatic differential), the controller will start the combustion cycle.

The controller has been preset at the factory to 185°F. To change the setting (because of a higher than normal heat load or cooler weather) use the following procedure.

NOTE: To reduce condensation in the firebox, it is not recommended to set the temperature below 185°F.

To Change the Setpoint

Push and hold the SET button until °F flashes and the setpoint is displayed. Change the value using the UP and DOWN Arrow buttons; then press the SET button. The setpoint will flash a few times and then the display will return to water temperature.

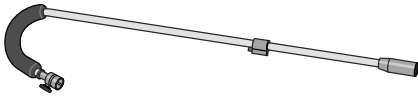

Outdoor Torch

The optional Outdoor Torch (p/n 2900325) is an excellent tool for starting a fire. Attaches quickly to an external propane tank and can be directed at the bottom of the fuel pile for quicker, easier combustion.

Initial Fire Up - Start of Heating Season

1. To start the furnace, press the SET button one time. The display will indicate "rSt" (reset) and after one or two seconds, the actuator will open and the fan will turn on (the fan icon on the controller will display).
2. Place dry kindling wood near the front of the firebox. Use a **small** amount of paper to light fire.
3. Add coal gradually to the fire but do not fill the firebox completely.
4. When the water temperature reaches the controller setting (185°F) and the actuator closes and the fan turns off, let the outdoor furnace cycle a few times to be sure it is operating properly; then add more coal.
5. After a few days of operation you will begin to learn how much coal is needed each day. If you only add the amount needed, it is easier to stir the ashes along the sides of the firebox and then to pull them over the grates (see Firebox Maintenance).

NOTE: Be sure to clean and inspect the firebox as outlined in Section 3.

CAUTION

Failure to clean the firebox as indicated will result in excessive corrosion.

Periodically during the normal operation of the outdoor furnace, look at the water temperature display. It should indicate a reading that is within 10°F of the controller setting.

A reading of 212°F or above indicates either a low-water condition or a malfunctioning temperature controller or snap disc (unless the door is open or not sealing properly). If the condition persists and the water level is correct, call your dealer for service.

CAUTION

If the water in the outdoor furnace boils, be sure to check the water level and restore to full. Add MolyArmor 350 (p/n 2900631) as needed (see Water Quality and Maintenance).

MODES OF OPERATION

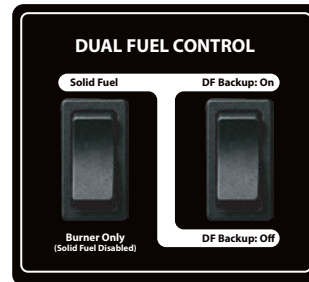

FireMax Dual Fuel outdoor furnaces with the optional burner kit installed are equipped with two rocker switches (located inside the pump access panel) for selecting the operational mode of the outdoor furnace. The first switch position can be set to Solid Fuel or Burner Only. The second switch is only enabled when the first switch is in the Solid Fuel position. It determines if the dual fuel backup burner operates as a backup to burning coal, or is disabled. If the power burner is not installed, the right switch is disabled completely.

NOTE: The first switch must stay in the Solid Fuel position until the power burner is installed. The actuator opens the combustion damper in the Solid Fuel mode whether or not the backup burner is enabled. When the Burner Only mode is used, the coal combustion damper stays closed.

A safety interlock switch is built into the firebox door so that if the firebox door is opened when the burner is operating, the burner will immediately shut down.

Solid Fuel

In Solid Fuel mode (first switch set to Solid Fuel, second switch set to DF Backup: Off), the outdoor furnace operates burning coal only in the firebox. The fire must be maintained in the firebox in order for the outdoor furnace to heat. On a call for heat, the actuator opens and the draft inducer fan turns on. Maintain adequate coals in the firebox for restarting the fire when loading the outdoor furnace with coal.

Dual Fuel Backup

If the Dual Fuel Backup mode is enabled (first switch set to Solid Fuel, second switch set to DF Backup: On), the outdoor furnace will operate by burning coal in the firebox. However, if there is a call for heat and the coal load is depleted, the outdoor furnace will activate the auxiliary burner until the firebox is reloaded with coal to sufficiently maintain heat. The Dual Fuel Backup mode will engage when the system water temperature drops to 145°F and will shut off once the water temperature reaches 160°F.

Burner Only

In this mode (first switch set to Burner Only), the outdoor furnace will operate the auxiliary burner to burn the backup fuel only. Operating temperatures are set with the digital controller.

OPERATING OPTIONAL BURNER

The dual fuel burner manufacturer's installation and operation manual is included with each type of burner supplied by WoodMaster. For specific operating instructions not included in this manual, refer to those instructions. All burner service work must be provided by a qualified serviceman according to the specifications and schedule in the burner manual.

Use only the fuel designated on the burner rating plate and stated in the gas or oil burner Operator's Manual. Also, if restarting after an ignition failure, purge the firebox of any excess fuel (or LP or NG) prior to attempting to restart the burner. If using fuel oil, use heating oil (either #1 or #2) of the proper viscosity for the coldest anticipated operating temperatures.

WARNING

DO NOT USE GASOLINE, CRANKCASE OIL OR ANY OIL CONTAINING GASOLINE. DO NOT ATTEMPT TO START THE BURNER WHEN EXCESS OIL HAS ACCUMULATED OR WHEN THE BURNER IS HOT.

Flue Draft Requirements

It is important to adjust the flue draft, by adding chimney height as needed, to between -0.01 and -0.03 inch of water column. Proper draft is essential for better, cleaner burning and is very important in a Dual Fuel model because switching between fuels can create varying combustion conditions.

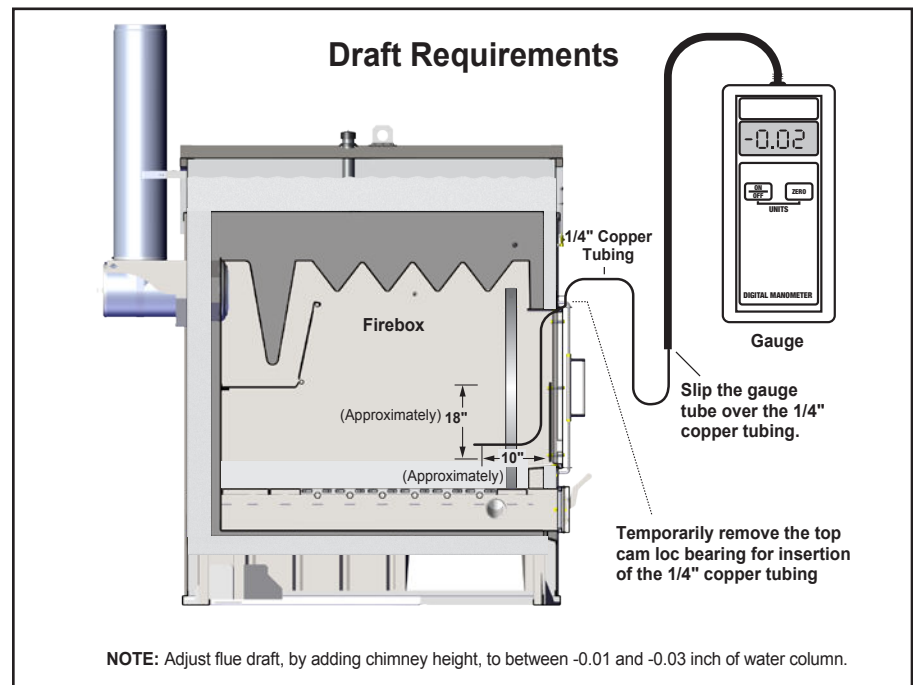

Filling the Firebox

Prior to loading the firebox with coal, **always** level the hot coals evenly over the grates. With the hot coals covering the grates, added coal ignites faster because combustion air is forced through the hot coals and into the newly added coal. If the coals are pushed to the back, a less efficient burn will result.

1. Before reloading, turn off power to the furnace; then open the ash clean out door. Place the extension tube over the shaker grate handle and move the shaker grates a few times until live coals fall into the ash pan. This helps to ensure proper airflow to the coal load in the firebox.
2. Unlatch the door; then stand behind the door and stay as far away as possible as the firebox door is opened as smoke and hot gases escaping through the firebox door opening could ignite. From a safe distance, observe the fuel load.

WARNING

Use extreme care if adding coal when coals are already present. Very hot gases may be coming out of the firebox door opening.

WARNING

Keep your face away and stay as far away as possible from the firebox door area when opening the door.

3. If necessary, clean the firebox of excess ashes and/or crusty deposits.
4. Pull and level the hot coals to evenly cover the shaker grates.

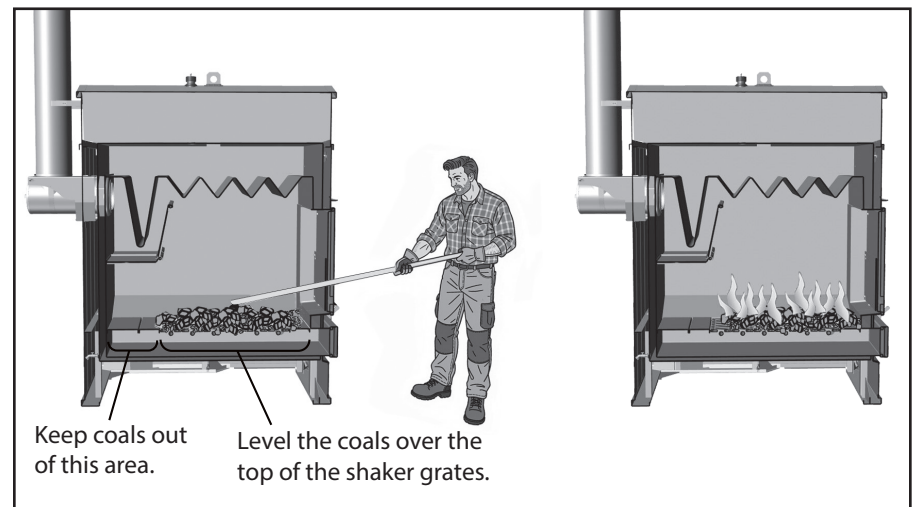

5. Add coal to the firebox making sure not to load past the bottom door frame.

NOTE: When adding coal, add the coal above the shaker grates. Do not add coal under the swinging baffle where there are no shaker grates.

6. Close and secure the firebox door. **Do not operate the outdoor furnace with the firebox door open.** Combustion in the firebox cannot be controlled if the firebox door is left open or unsecured. If the firebox door is left open, an uncontrolled burn will result. To return to a controlled burn, close and secure the door.

Adding Heat Load

NOTE: During initial start-up, a considerable amount of moisture from condensation will collect inside the firebox. This is normal and the moisture will evaporate after the first couple of fuel loads.

1. With no heat load draw in the system, monitor the operation of the outdoor furnace until the water temperature reaches the water temperature setpoint.
2. Turn on the pump(s); then start a heat load draw in the system by turning up the thermostat in the house. Monitor the outdoor furnace for one hour or until another cycle occurs (i.e., outdoor furnace goes from combustion to idle mode). If the water temperature drops and does not recover to the water temperature setpoint within one hour of starting the heat load draw, the heat load draw should be shut off, allowing the furnace to cycle to the idle mode again.

NOTE: The outdoor furnace will not operate satisfactorily if the heat load is higher than the output capacity of the outdoor furnace.

3. At this point, there should be glowing coals established in the bottom of the firebox. The firebox can be filled with coal making sure not to load past the bottom door frame.

Electronic Temperature Controller

Energy Start Shut-Down:

This function closes the actuator and turns off the fan when not in use and the back-up system is operating (e.g., if gone for the weekend, the furnace runs out of coal and the backup system takes over). To restart, simply push the SET button.

Start Up / Reset:

The first time the furnace is powered up or when it has shut down, the controller display will flash "LA (Low Alarm)" two times, display the water temperature for two seconds and then start over. This is normal and indicates the system has shut down because the water is at or below 120°F.

To start up (or reset) your furnace, press the SET button one time. The display will indicate "rSt" (reset) and after one to two seconds, the actuator will open and the fan will turn on (the fan icon on the controller will display). The display will continue to flash "LA" and the water temperature will be displayed until the water temperature reaches 140° (ALL + 20). After the water temperature reaches 140°F, only the water temperature will be displayed until the water temperature falls to 120°F.

NOTE: The power switch must be in the ON position.

NOTE: The power switch can be shut off when loading or for servicing.

Parameter Description and Factory Settings:

- Set (setpoint) - 185°F
- Hy (Differential) - 2°F
- ALL (Low Alarm) - 120°F

How To:

- **View Setpoint** — Push and immediately release the SET button. The display will indicate setpoint and will return to water temperature after five seconds.
- **Change the Setpoint** — Push and hold the SET button until °F is flashing and the setpoint is displayed. Change the value using the UP and DOWN Arrow buttons, and press the SET button. The setpoint will flash a few times and then the display will return to water temperature.
- **Change Hy or ALL** — Push and hold the SET and DOWN Arrow buttons at the same time until HY is displayed. Using the UP and DOWN Arrow buttons, select the parameter to be changed (Hy or ALL), push the SET button once (value of parameter should be displayed), use UP and DOWN arrow buttons to change the value, and push the SET button (value should flash a few times). After 10-15 seconds the display will change back to water temperature.

Electric Controller Reference

1. GENERAL WARNING

1.1 PLEASE READ BEFORE USING THIS REFERENCE MATERIAL

- This information should be kept near the controller for easy and quick reference.
- The controller shall not be used for purposes different from those described in this manual. It cannot be used as a safety device.
- Check the application limits before proceeding.

1.2 SAFETY PRECAUTIONS

- Check the supply voltage is correct before connecting the controller.
- Do not expose to water or moisture; use the controller only within the operating limits, avoiding sudden temperature changes with high atmospheric humidity, to prevent formation of condensation.

WARNING

WARNING: disconnect all electrical connections before any kind of maintenance.

- The controller must not be opened.
- In case of failure or faulty operation, contact your dealer with a detailed description of the fault.
- Ensure that the wires for probes, loads and the power supply are separated and far enough from each other, without crossing or intertwining.

2. GENERAL DESCRIPTION

The controller is designed to control the furnace water temperatures between factory settings or between the parameters that are selected by the operator.

3. CONTROLLING LOADS

3.1 THE REGULATION OUTPUT

The regulation is performed according to the temperature measured by the probe.

When the appropriate temperature, SP or HY, is reached the controller will respond and control the actuator and fan accordingly.

The Hy value is automatically set under the Setpoint. If the temperature decreases and reaches the setpoint minus the differential, the regulation output is activated and then turned off when the temperature reaches the setpoint value again.

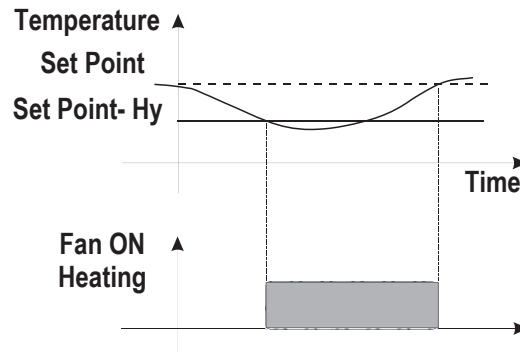

4. FRONT PANEL COMMANDS



SET: Displays the target setpoint; selects and confirms a parameter in the programming mode. Also used in conjunction with the UP and DOWN Arrow buttons to view the Min and Max recorded temperatures and to reset the stored temperatures.

UP Arrow Button: To see HI temperature since last reset; in programming mode it browses the parameter codes or increases the displayed value.

DOWN Arrow Button: To see LO temperature since last reset; in programming mode it browses the parameter codes or decreases the displayed value.

KEY COMBINATIONS:





UP Arrow Button + DOWN Arrow Button - To lock and unlock the keyboard.

SET Button + DOWN Arrow Button - To enter in programming mode.

SET Button + UP Arrow Button - To return to the temperature display.

4.1 USE OF LEDS

Each LED function is described in the following table.

LED	MODE	FUNCTION
	ON	Output enabled.
	Flashing	Alarm (Push SET).
	Flashing	Programming Phase.
	ON	Temperature Alarm. Stays on until reset and temperature is 20° more than ALL.

5.1 HOW TO SEE MAX/MIN TEMPERATURES

If the alarm LED is on, an alarm has taken place. To see the kind of alarm (the max/min reached temperatures):

1. Push the UP or DOWN Arrow button.
2. The controller displays the temperature once again.

6. MAIN FUNCTIONS

6.1 HOW TO SEE THE SETPOINT

Push and immediately release the SET button. The display will show the Setpoint value. Push and immediately release the SET button or wait for five seconds to display the probe value again.

6.2 HOW TO CHANGE THE SETPOINT

1. Push the SET button for more than two seconds to change the Setpoint value.
2. The value of the setpoint will be displayed and the °F starts blinking.
3. To change the SET value, push the UP or DOWN Arrow button within 10 seconds.
4. To memorize the new Setpoint value, push the SET button again or wait 10 seconds.

6.3 HOW TO CHANGE A PARAMETER VALUE

1. Enter the Programming mode by pressing the SET button and the DOWN button for three seconds (the °F LED starts blinking).
2. Select the required parameter. Press the SET button to display its value.
3. Use the UP or DOWN Arrow button to change its value.
4. Press the SET button to store the new value and move to the following parameter.

To exit: Press the SET button + the UP Arrow button or wait 15 seconds without pressing a key.

NOTE: The SET value is stored even when the procedure is exited by waiting for the time-out to expire.

6.4 HOW TO LOCK THE KEYBOARD

1. Press and hold the UP and DOWN Arrow buttons for more than three seconds.
2. The "POF" message will be displayed and the keypad will be locked. At this point it will be possible only to see the setpoint or the MAX (and) MIN temperature stored.
3. If a button is pressed for more than three seconds, the "POF" message will be displayed.

6.5 TO UNLOCK THE KEYBOARD

Press and hold the UP and DOWN Arrow buttons for more than three seconds until the "Pon" message is displayed.

7. PARAMETERS

REGULATION

Hy Differential: (1 ÷ 255 °F) Intervention differential for setpoint. Fan Cut IN is Setpoint Minus Differential (Hy). Fan Cut OUT is when the temperature reaches the setpoint.

ALARM

ALL Minimum temperature alarm: (120°F) when this temperature is reached, the alarm is enabled and fan will shut off.

8. ALARM SIGNALS

Message	Cause	Outputs
"LA"	Minimum temperature alarm	Outputs unchanged

8.1 ALARM RECOVERY

Probe alarm "P1" starts several seconds after the fault in the related probe; it automatically stops several seconds after the probe restarts normal operation. Check connections before replacing the probe.

Temperature alarms "DA" and "LA" automatically stop as soon as the thermostat temperature returns to normal values.

9. DEFAULT SETTING VALUES

Label	Name	Range	°F
Set	Setpoint	150°F - 195°F	185
Hy	Differential	1°F - 45°F	2
ALL	Minimum temperature alarm	120°F - 140°F	120

Fig. 1



Fig. 2



Fig. 3



Fig. 4



Fig. 5



Fig. 6



Changing Settings

Changing the Setpoint

1. Press and hold the SET button for three seconds or until the °F is flashing. The number that appears is the Setpoint (Fig. 1).
2. Use the UP or DOWN Arrow button to adjust the setting.
3. Press the SET button to lock in the settings.

Changing the Hy

1. Press and hold the DOWN Arrow button and SET button until the display reads Hy (Fig. 2).
2. Release the DOWN Arrow button and SET button.
3. Press the SET button. The number displayed is the differential (Fig. 3).
4. Press the UP Arrow or DOWN Arrow button to adjust (Fig. 4).
5. Press the SET button (Fig. 5).
6. The display will read ALL for approximately 30 seconds (Fig. 5). It will then return to the water temperature reading (Fig. 6).

Changing the ALL

1. When the controller reads ALL, press the SET button. The number that appears is the Low Alarm temperature.
2. To adjust the number, press the UP or DOWN Arrow button.
3. Press the SET button to lock in the setting.

Definitions

Setpoint - The temperature at which the fan will shut off, until hysteresis (i.e., the temperature "gap") is achieved.

Hy, aka Differential - The amount in degrees the temperature has to drop in order to start the fan.

ALL, aka Low Alarm - The temperature at which the furnace will shut down. The furnace should be reloaded and the controller be reset.

CAUTION: Do not set your SP value lower than your ALL value.

Digital Aquastat Factory Settings	Settings Minimum/Maximum
Setpoint (SP)	185°F / 150°F - 195°F
Differential (HY)	2°F / 1°F - 45°F
Low Alarm (ALL)	120°F / 12-°F - 140°F

Maintenance Schedule

PREVENTIVE MAINTENANCE SCHEDULE

Regular maintenance and inspections can help extend the life of your outdoor furnace and prevent high-cost repairs. This table is meant to serve as a general guideline until you become acquainted with how the outdoor furnace operates with your specific application.

OPERATION	SERVICE INTERVAL							See Section Number
	Before first operation of season	Daily	Weekly	Monthly	Semi-Annually	Post Season		
Check water level.	●	●						1
Completely remove ash.						C	●	6
Inspect firebox door seal.			D				●	4
Inspect chimney.	●	A	●				●	5
Check vent cap.	●	A						2
Stir firebox ash and remove ash from cleanout.			B					3
Scrape bottom of firebox.				●			●	7
Lubricate door handle.						●		8
Check pH and moly levels of water.	●					E	●	F

NOTE: Check daily for build-up of creosote until experience shows how often cleaning is necessary.

- A When the outdoor furnace is new, daily for the first week.
- B Twice a week.
- C After one month, then midway through the heating season.
- D Weekly until interval for your application can be determined.
- E When new, after three months, then every six months thereafter.
- F Refer to **Water Quality and Maintenance**

Control Locations

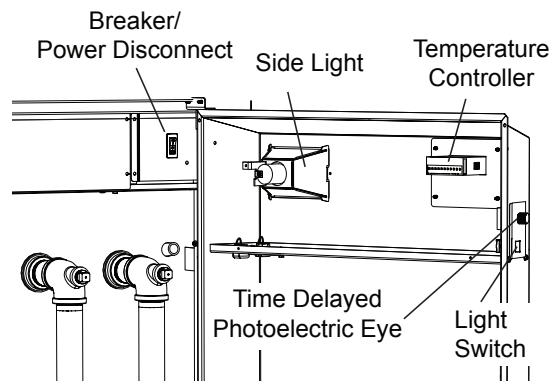

ROUTINE MAINTENANCE

⚠ CAUTION

Use only genuine WoodMaster Parts and Accessories if it ever becomes necessary to replace any component of the outdoor furnace.

Routine inspections and maintenance are essential to the proper operation and longevity of the outdoor furnace. The items indicated in the preventive maintenance schedule are intended to serve as a guideline. Actual intervals between inspections and maintenance may vary depending on a number of factors, including your heat load requirements, type of coal used and outdoor temperatures.

NOTE: Proper maintenance of the firebox, chimney transition box and chimney tee are essential for the outdoor furnace to function properly and for longevity.

⚠ CAUTION

Do not burn plastic, garbage, treated wood or fuels not listed for this outdoor furnace.

NOTE: Chloride or sulfurous gases can be generated if plastic or rubber is burned and will mix with moisture to form hydrochloric or sulfuric acids in the firebox, creating corrosion.

NOTE: If the outdoor furnace is operated correctly, creosote will not form in the chimney.

The chimney connector and chimney should be inspected at least twice monthly during the heating season to determine if a creosote buildup has occurred, and to check for corrosion or condensation. If creosote has accumulated it should be removed to reduce the risk of a chimney fire.

⚠ WARNING

The chimney and chimney connector must be clean and in good condition.

MAINTENANCE SECTIONS

Refer to the Preventive Maintenance Schedule for the recommended intervals with which to perform these maintenance items.

Section 1 - Water Level

Open the sight gauge valve. The sight gauge tube will fill to indicate the level of water in the outdoor furnace. Be sure to close the sight gauge valve after checking water level. The sight gauge valve and tube will drain when the valve is closed.

Section 2 - Vent Cap

Check that the vent cap fits loosely on the vent opening. Check the vent cap copper tube for obstruction; clean with a pipe cleaner if needed.

WARNING

The outdoor furnace vent cap must fit loosely on the vent opening. Do not force the cap down or try to seal it tightly onto the vent pipe. Do not extend or restrict the vent pipe or opening. DO NOT ALLOW THE OUTDOOR FURNACE TO BE PRESSURIZED.

Section 3 - Stir Ash

Stir the ashes in the firebox and pull them over the shaker grates. It is especially important to scrape the walls and the four corners at the ash line and below. If this maintenance operation is not performed as directed, deterioration can result from the moisture trapped between the ashes and the steel.

1. Remove ashes from the cleanout. Ashes should be cleaned out before the ash cleanout is half full.

CAUTION

Always wear the appropriate personal protective gear when cleaning ashes from the firebox.

2. **Disposal of ashes** - Place ashes in a metal container with a tight-fitting metal lid. It can take many days before the ashes are completely cooled. Other waste should not be placed in this container.
3. Each time the ashes are cleaned out, inspect the door rope (see Section 5) to make sure it is sealing properly.

WARNING

When cleaning the outdoor furnace, be careful not to spill any hot ash outside of the noncombustible container.

Section 4 - Firebox Door Seal and Bushings

The firebox door rope must be in good condition to ensure an airtight seal. Look for wear spots or portions of the door rope lacking an indentation from the firebox door. The door rope should have a uniform indentation in it all the way around.

1. Open the firebox door. One way to check that the door rope is sealing all the way around the firebox door is to insert a piece of paper similar in size and shape to a dollar bill in several locations around the perimeter of the door and then to close and latch the firebox door.
2. At each location, pull on the piece of paper. If it pulls out easily, either the door rope is sealing improperly and needs to be replaced, or the firebox door needs to be adjusted.
3. Check that the damper is properly sealing when closed.
4. Inspect the door and heat shields. It is normal for heat shields to show wear over time. The heat shield should be replaced if it is no longer providing coverage of the door beneath the heat shield.

NOTE: If the outdoor furnace has been improperly operated with the door partially open, close the door and allow the outdoor furnace to cycle normally for 1 hour before inspecting the door for proper sealing.

Section 5 - Chimney

NOTE: Creosote is an accumulation of combustion by-products on the surfaces of outdoor-burning appliances. Twice a month during the heating season, inspect for excessive creosote buildup on the firebox walls, flue and chimney. If present, the buildup should be removed for proper operation and fire safety. Creosote, if ignited in the chimney, results in an extremely hot chimney fire. In case of a chimney fire, close the firebox door.

1. If the flue passageway behind the baffle becomes plugged, it must be cleaned.
2. Inspect the chimney for excessive buildup of creosote and clean, if necessary.

Section 6 - Completely Remove Ash

1. Remove all ashes from the firebox.

CAUTION

Always wear the appropriate personal protective gear when cleaning ashes from the firebox.

2. Use a wire brush and small scraper to clean the firebox, side walls, back wall and ash pan. Use a light to inspect for corrosion. If corrosion is present, contact your dealer.
3. Inspect shaker grates and air delivery system for wear and damage. Verify that the shaker grates tilt properly in both directions. Replace any worn or damaged parts.
4. **Disposal of ashes** - Place ashes in a metal container with a tight-fitting metal lid. It can take many days before the ashes are completely cooled. Other waste should not be placed in this container.
5. Each time the ashes are cleaned out, inspect the door rope (see Section 5) to make sure it is sealing properly.

WARNING

When cleaning the outdoor furnace, be careful not to spill any hot ash outside of the noncombustible container.

Section 7 - Scrape Bottom of Firebox

Scrape the bottom 12 inches of the firebox clean. Allow the fire to get very low; then move the coals to one side of the firebox.

Use a hoe to clean the other side. Move the coals to the other side and finish cleaning the firebox, leaving some ashes with the live coals. Pull the coals and ashes over the shaker grates. When the furnace is filled, the coals remaining in the firebox will light the fire.

NOTE: Regular cleaning of the firebox, particularly at the ash line and below, reduces the possibility of corrosion.

The top of the firebox and walls of the firebox above the ash line should be scraped clean if large, thick, dry or crusty deposits are present. A thin, tar-like layer of creosote does not cause any problems in the operation of the furnace.

Section 8 - Door Handle

Lubricate the door handle with a light petroleum distillate (e.g., WD-40 or equivalent).

SERVICEABLE ITEMS

NOTE: These procedures should be performed by a qualified individual and in accordance with any and all federal, state/provincial and local codes and regulations. When performing work on an appliance observe all precautions in the literature, tags and labels attached to the appliance and other safety precautions that may apply. When working with electricity and electrical components, failure to follow precautions could result in property damage, personal injury or death.

NOTE: If any of these items are under warranty, remember that the warranty covers only the cost of the replacement part. Labor is not covered.

NOTE: Use only genuine WoodMaster parts and accessories if it ever becomes necessary to replace any component on the outdoor furnace.

FIREBOX DOOR CAM LOC ADJUSTMENT

If the firebox door rope has been replaced and it is not sealing properly, the firebox door may need to be adjusted to close more tightly. When adjusting the firebox door, make sure it is not adjusted too tightly as damage to the firebox door, frame or door rope may result.

1. Loosen the adjustment nut (two nuts on the dual Cam Loc® style door) and slide the lock assembly in slightly toward the furnace; then tighten securely. On the dual Cam Loc doors, make sure to adjust both the top and bottom for equal pressure when latched.

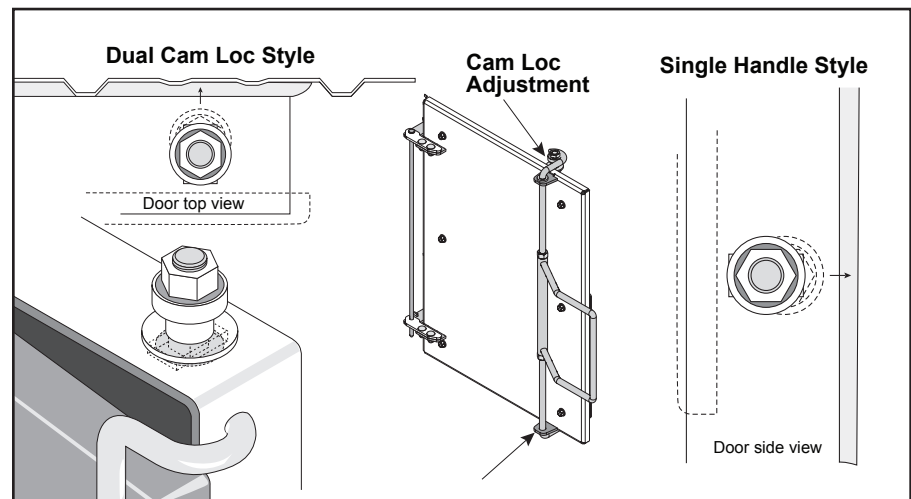

FIREBOX DOOR SEAL ROPE

The firebox door seal must be in good condition to ensure an airtight seal. If replacement is necessary due to the firebox door seal becoming damaged or brittle, use the following procedure:

1. Disconnect power to the furnace. Open the firebox door.

WARNING

Remove all coals and ash from the firebox and allow the outdoor furnace to thoroughly cool down before performing maintenance.

2. Using a scraper, remove the firebox door seal rope and clean any remaining silicone adhesive from the groove. Any residue left in the groove will interfere with the new seal.
3. Apply a 1/4" (6 mm) diameter bead of silicone sealant into the entire firebox door seal groove.
4. Starting at the center of the top side of the firebox door, insert the new door seal rope into the groove, pressing it firmly into the bead of silicone sealant. Make sure the firebox door seal rope is not stretched as it is pressed into the corners. Force the firebox door seal rope out to fill in the corners as shown.

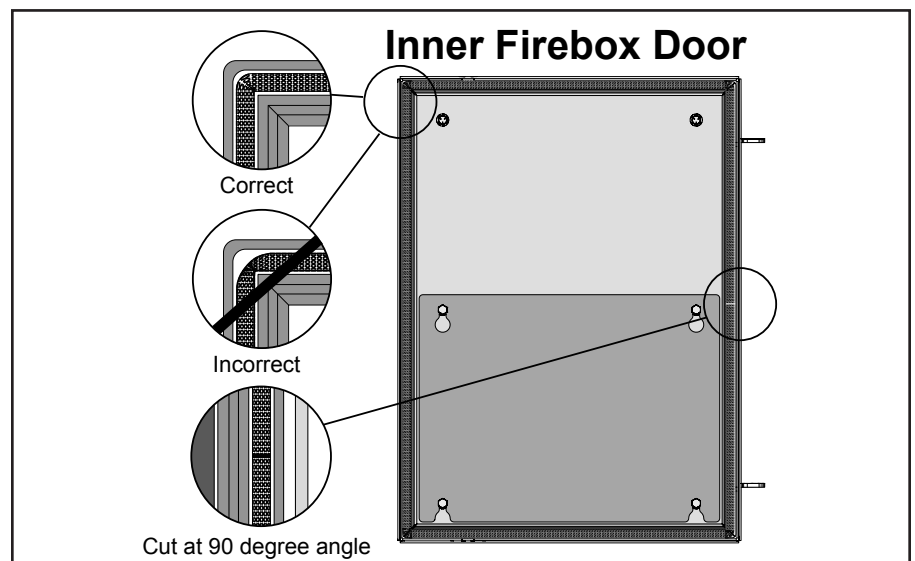

5. When the seal has been pressed into the groove all the way around the firebox door, cut the end of the rope about one inch (2.5 cm) longer than required and press it tightly against the beginning end of the rope.
6. Close the firebox door.

ASH REMOVAL DOOR SEAL

The ash removal door seal must be in good condition to ensure an airtight seal. If replacement is necessary due to the ash collection chamber door seal becoming damaged or brittle, use the following procedure:

1. Disconnect power to the furnace.
2. Open the ash removal door.
3. Use a flat shovel and hoe to remove all the ash from the ash collection chamber. Be careful not to push ash or debris into the under air outlet.

WARNING

Remove all ash from the ash collection chamber.

4. Using a scraper, remove the ash removal door seal rope and clean any remaining silicone adhesive from the groove. Any residue left in the groove will interfere with the new seal.
5. Apply a liberal amount of silicone sealant into the entire ash removal door seal groove.
6. Starting at the center of the hinge side of the ash removal door, insert the new door seal rope into the groove, pressing it firmly into the bead of silicone sealant. Make sure the ash removal door seal rope is not stretched as it is pressed into the corners. Force the door seal rope out to fill in the corners as shown.

Ash Removal Door

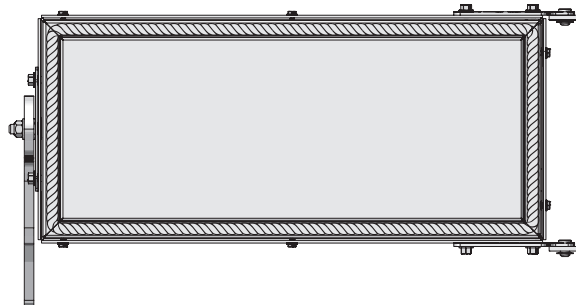

6. When the seal has been pressed into the groove all the way around the door, cut the end of the rope about one inch longer than required and press it tightly against the beginning end of the rope.
7. Close the ash collection chamber door and securely latch.

LIGHT BULB

A 40-watt appliance type bulb is installed in each of the fixtures on the outdoor furnace. Do not install a bulb in excess of 60 watts.

1. Disconnect power to the furnace.
2. Remove the two screws securing the clear plastic lens over the light.
3. Replace the bulb.
4. Ensure that the gasket is aligned correctly; then install the plastic cover and secure with two screws.

TEMPERATURE CONTROLLER

1. Disconnect the electrical power at the main power source to the outdoor furnace; then open the control panel door. Remove the screws securing the inner door panel; then remove the panel.

WARNING

Do not attempt service inside the electrical control panel without first disconnecting the electrical power at the main power source.

2. Carefully label each of the wires connected to the temperature controller according to the numbered connections identified on the top of the controller.
3. Using a small screwdriver, loosen the screws securing each of the wires; then pull the wires out of the controller.
4. Depress the tabs on the side of the controller mounting strap; then slide the strap off the controller. Remove the controller from the control panel.
5. Place the new gasket onto the controller. Slide the new controller into position (making sure it is positioned upward) in the control panel; then secure with the mounting strap.
6. Slide each of the labeled wires into their proper positions on the controller; then tighten each of the screws securely.
7. Place the inner door panel into position on the door and secure with the screws.
8. Close and secure the door. Connect power to the outdoor furnace.

WATER TEMPERATURE SENSOR

WARNING

Do not attempt service inside the electrical control panel without first disconnecting the electrical power at the main power source.

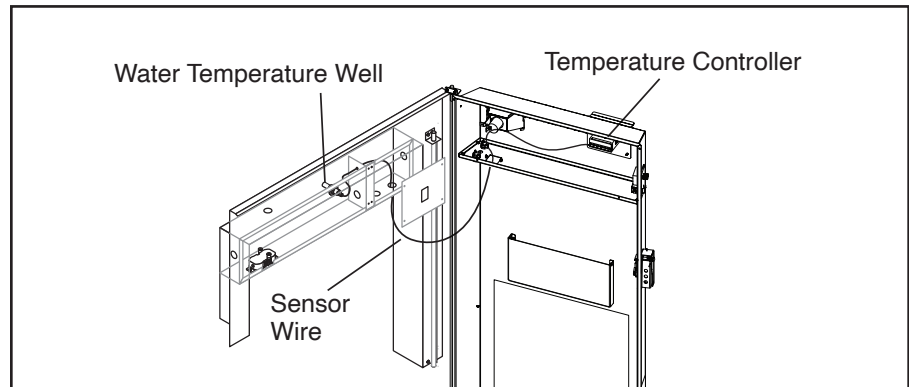

To test the water temperature sensor using a multimeter, see Testing Water Temperature Sensor. If the sensor needs to be replaced, see Replacing Water Temperature Sensor.

TESTING WATER TEMPERATURE SENSOR

The controller displays "P1" if the sensor is disconnected or has failed, or if there is a short circuit in the sensor. This can be verified with a multimeter by following these steps:

1. Disconnect the electrical power at the main power source to the outdoor furnace; then open the control panel door. Remove the screws securing the access box panel; then remove the panel.

WARNING

Do not attempt service inside the electrical control panel without first disconnecting the electrical power at the main power source.

2. Disconnect the sensor wires from the controller.
3. Using a multimeter set to Ohms, touch the meter leads to the wires disconnected from the controller. A reading of more than 1000 Ohms indicates the temperature sensor is faulty and should be replaced.

REPLACING WATER TEMPERATURE SENSOR

1. Disconnect the electrical power at the main power source to the outdoor furnace; then open the control panel door. Remove the screws securing the access box panel; then remove the panel.

⚠ WARNING

Do not attempt service inside the electrical control panel without first disconnecting the electrical power at the main power source.

2. Disconnect the sensor wires from the controller.
3. Remove (by pulling) the sensor from the well.
4. Firmly press the new sensor into the well. Secure the sensor in place following the instructions provided with the new sensor.
5. Connect the sensor wires to the controller.
6. Place the access box panel into position and secure with the screws.
7. Close and secure the door. Connect power to the outdoor furnace.

REPLACING SWINGING BAFFLES

⚠ WARNING

Remove all coals and ash from the firebox and allow the outdoor furnace to thoroughly cool down before replacing swinging baffles.

1. Disconnect power to the furnace. Open the firebox door.
2. The swinging baffles can be removed by lifting up and pulling out to clear the brackets. To install, reverse the step.

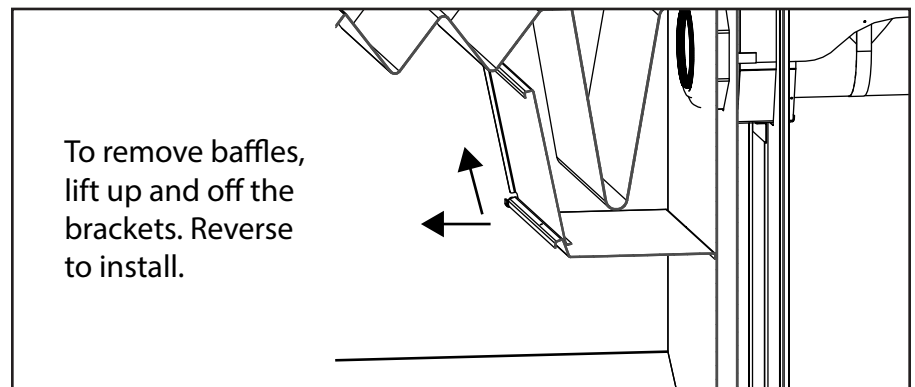

TROUBLESHOOTING

A. OUTDOOR FURNACE DOES NOT HEAT (BUILDING IS LOSING TEMPERATURE)

1. **Out of coal** - Check firebox to see if fire is out. Add coal as necessary. Note that coal quality can differ greatly depending on where and how it is mined. It may be beneficial to source coal from a different supplier.
2. **Circulation valve(s) closed** - Be sure all valves in the system are open.
3. **Circuit breaker off** - Check the circuit breaker that supplies power to the outdoor furnace.
4. **Damper not operating properly** - Disconnect power to the furnace; then check the fuse in the control panel. Check damper for obstructions and for free movement. Be sure damper works freely; then reset the breaker, if needed.
5. **Circulation pump(s) not operating** - Check that circulation pumps are operating. If not, disconnect power to the pump. Close valves at the pump. Disassemble the pump and try to turn the pump shaft. If necessary, replace the pump. Follow instructions supplied with the pump.
6. **Air in system** - Check for air in the water lines or heat exchangers. If you hear a gurgling sound in a heat exchanger, air is present in the system. Shut off the pump, wait 15 seconds and start the pump. If it is necessary to force air from lines, refer to Start-up Procedures and Installation Guide.
7. **Outdoor furnace exhaust obstructed** - When firebox is empty, remove the chimney tee and use a small mirror to inspect chimney. Clean if needed.
8. **Building(s) poorly insulated or uninsulated** - Poorly insulated or uninsulated buildings, buildings with uninsulated or poorly insulated ceilings, or a lack of proper insulation under radiant flooring can cause excessive fuel consumption and/or heating problems.
9. **Supply and return lines installed incorrectly** - Make sure the hot supply water line is connected to the correct fitting on the outdoor furnace and heat exchanger.
10. **Circulation pump(s) installed backwards** - Check that pump flow direction is correct. If not, shut off power to pump. If the flow is not in the correct direction, disconnect pump from water line and reverse pump mounting to correct flow direction. If the pump is not mounted on the outdoor furnace, check for proper pump mounting location.
11. **Underground supply and return lines insulated poorly** - Heat loss from poorly insulated underground supply and return lines is often indicated by an unusually high amount of snow melting above the lines when the ground temperature is 10°F or colder.
12. **Supply and return lines uninsulated** - Uninsulated supply and return lines in areas that are not intended to be heated (unheated crawl spaces, etc.) may cause excessive heat loss. Insulate the supply and return lines.
13. **Poor water quality** - Water with high amounts of solids, sand or dirt can create deposits inside the wall of heat exchanger components, reducing the amount of heat output. If this condition is suspected, contact your dealer.

B. OUTDOOR FURNACE IS OVERHEATING

1. **Air entering through the door** - Make sure the firebox door is properly latched and check the condition of the door rope. If it is not sealing properly (indicated by a uniform indentation in the rope), replace the rope. If door does not close tightly, adjust using the appropriate procedure (see Owner Serviceable Items).
2. **Air entering through the damper** - Check to be sure the damper is operating correctly as explained in section A.4. Be sure the damper closes all the way and that no obstructions are present.

NOTE: If the water in the outdoor furnace boils, identify the cause and correct immediately. The outdoor furnace will not typically be damaged by boiling unless it reduces the water level more than 1" below the full mark on the sight gauge. If water boils, restore water level to full and add MolyArmor 350 as needed. If water is added frequently it will cause deterioration in the water jacket which will reduce the life of the outdoor furnace.

3. **Temperature controller set incorrectly** - The temperature controller should not be set above 195°F.
4. **Water is not circulating** - The pump should run continuously and water needs to circulate continuously through the supply and return lines to keep water temperature uniform in the outdoor furnace.
5. **Circulation valve(s) closed** - Be sure the proper valves in the system are open to allow circulation.

C. FREQUENT PUMP TROUBLE OR POOR WATER CIRCULATION

1. **Pump mounted incorrectly** - If the pump is not mounted on the outdoor furnace, it must be mounted at a minimum of four feet lower than the top water level in the outdoor furnace.

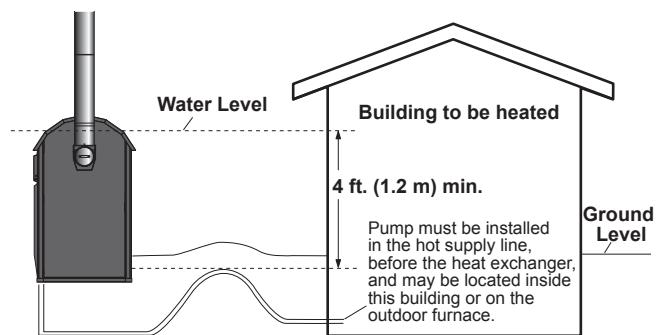

© 2018 Central Boiler

Make sure the pump motor is installed in a horizontal position. The junction box must not be located below the pump motor. If necessary, remove the four screws and rotate the pump body.

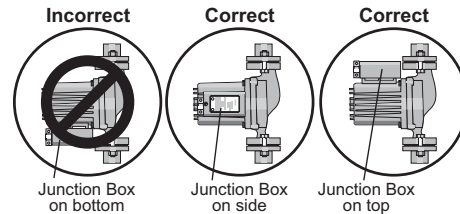

2. **Water will not circulate** - If the system has been drained and refilled, or if the system has been opened for any reason (e.g., replacement of pump, adding heat exchangers, repairing a leak), the system must be purged (see Initial Start-up Procedures and Installation Guide).
3. **Poor water quality** - Water with high amounts of solids, sand or dirt can cause frequent pump failure. Use softened and/or filtered water.
4. **Deposits in water lines/heat exchanger walls** - If water high in silica or other mineral content has been used, material deposits may build up on the insides of the supply and return lines and on the heat exchanger walls. If this occurs, the system will need to be drained and then cleaned using Sludge Conditioner (p/n 166). The system must then be refilled with the proper amount of MolyArmor 350 Corrosion Inhibitor (p/n 2900631) and fresh water.

D. BURNING AN EXCESSIVE AMOUNT OF COAL

1. **High volume water heating** - High volume water heating (e.g., car wash, swimming pool, etc.) will require high coal consumption.
2. **Excessive heat loss** - See items 9-12 of Building is Losing Temperature.
3. **Air entering though door** - See item 1 of Outdoor Furnace is Overheating.
4. **Excessive draft** - If a very tall extension is added to the chimney, the increased draw through the draft may cause excessive coal consumption. Decreasing the draft opening may increase efficiency and reduce coal consumption.
5. **Supply and return line heat loss** - If not using ThermoPEX, supply and return lines buried in a wet, low-lying area may cause a large heat loss that will greatly increase coal consumption.
6. **High heat demand** - Concrete slabs (with radiant heat) that are poorly insulated or are exposed to water or cold outside temperatures will require increased coal consumption (see Hydronic Installations section). Bringing a cold concrete slab up to temperature the first time will take a considerable amount of time and coal; once warm, coal consumption will be reduced if the concrete slab and building are insulated properly. The following will also have a high heat demand: poorly insulated buildings, buildings with large amounts of glass windows/doors, buildings with overhead doors, greenhouses, uninsulated crawl spaces, outdoor air infiltration and air leaking through foundation.

GENERAL INFORMATION

Make note of these precautionary statements, also found on the outdoor furnace.

DO NOT BURN GARBAGE



Burning garbage causes damage to components of coal burning appliances.

HPBA Refer to your Owner's Manual.

BURN RESPONSIBLY

Preserve Your Right to Burn Coal

- Before installing, ALWAYS consider the direction that the chimney exhaust will travel with prevailing winds.
- BEFORE operating, the furnace must be installed with adequate chimney height. If there is a residence not served by the furnace within 300 feet (91.5 meters), the chimney must be 2 feet (0.6 meters) higher than the peak of the residence it serves. If there is a residence not served by the furnace within 100 feet (30.5 meters), the chimney must be 2 feet (0.6 meters) higher than the peak of the residence served or not served, whichever is higher. Proper chimney height will aid in dispersing the chimney exhaust. Chimney height may need to be greater than the above minimum requirements. The outdoor coal furnace must be installed in accordance with the manufacturer's recommendations and/or in accordance to all applicable codes and regulations, whichever is more stringent. Refer to your Owner's Manual.
- ONLY burn the proper fuels specified.
- DO NOT create a nuisance. Be certain your chimney exhaust is not adversely affecting neighbors. Creating a nuisance may affect your right to burn coal. If any issue with chimney exhaust arises, take immediate action to solve the issue.
- Properly dispose of ashes into a metal container with a cover.
- It's been said that lighting a fire can be more of an art than a science. You may need to vary techniques to achieve best results. Many factors can have a significant effect such as size and type of coal, coal storage, etc. Over time, you will become familiar with your particular conditions. This will allow you to identify cause and effect in a variety of circumstances and what works best for your conditions.

Protect your right to heat with coal. Careless operation may result in a loss of your rights.

pin 7000497 Rev. B

WARNING

For safety, keep firebox door latched. Leaving the firebox door open may lead to a runaway fire. In the event of a runaway fire, close the firebox door.

AVERTISSEMENT

Par mesure de sécurité, maintenez la porte de tirage verrouillée. Le fait de laisser la porte de tirage ouverte peut entraîner un incendie échappé. En cas d'incendie échappé, fermez la porte de tirage.

CAUTION

Do not start fire until water level is full. Keep face away from firebox door area.

PRÉCAUTIONS À PRENDRE

N'allumez pas le feu tant que le niveau d'eau n'est pas plein. Gardez le visage éloigné de la porte de tirage et de ses alentours.

pin 7000211

DANGER

- Risk of fire or explosion. DO NOT burn garbage, gasoline, drain oil, lighter fluids or other flammable liquids.

DANGER

- Risque d'incendie ou d'explosion. NE brûlez PAS de déchets, d'essence, d'huile de vidange, de liquide d'allumage ou autres liquides inflammables.

WARNING

- Risk of fire.
- DO NOT operate with fuel loading or ash removal doors open.
- DO NOT store fuel or other combustible materials within marked installation clearances.
- Inspect and clean flues and chimney regularly.
- DO NOT install or operate furnace before first reading and understanding the Owner's Manual.
- DO NOT allow others to install or operate furnace without first reading and understanding the Owner's Manual.
- DO NOT leave furnace unattended with this door or the firebox door unlatched.

AVERTISSEMENT

- Risque d'incendie.
- NE vous servez PAS de la chaudière avec les portes d'alimentation en combustible ou d'enlèvement des cendres ouvertes.
- NE stockez PAS le combustible ou autres matériaux combustibles dans le périmètre d'installation indiqué.
- Inspectez et nettoyez régulièrement les carneaux de fumée et la cheminée.
- N'installez PAS et ne vous servez PAS de la chaudière avant d'avoir lu et compris le manuel du propriétaire.
- NE laissez PAS d'autres personnes installer ou faire fonctionner la chaudière avant d'avoir lu et compris le manuel du propriétaire.
- NE laissez PAS la chaudière sans surveillance si cette porte ou la porte du foyer ne sont pas verrouillées.

CAUTION

- Hot surfaces.
- Keep children away.
- DO NOT touch during operation.
- DO NOT burn treated wood, plastics or rubber in the furnace.
- Maximum draft marked on the nameplate.
- ALWAYS comply with all applicable codes and regulations.
- ALWAYS take care when adding fuel to the furnace to prevent hot coals from falling out.
- ALWAYS store ashes in a covered non-combustible container.

PRÉCAUTIONS À PRENDRE

- Surfaces brûlantes.
- Tenir les enfants éloignés.
- NE PAS toucher durant le fonctionnement.
- NE PAS faire brûler de bois traité, du plastique ou de caoutchouc dans la chaudière.
- Tirage maximum indiqué sur la plaque signalétique.
- TOUJOURS se conformer à toutes les directives et réglementations en vigueur.
- Faire TOUJOURS attention lors de l'ajout de charbon dans la chaudière, afin d'éviter que du charbon brûlant ne tombe en dehors.
- TOUJOURS stocker les cendres dans un récipient couvert non combustible.

pin 7000244

CAUTION

ANY TIME WATER IS ADDED, the furnace MUST BE immediately heated to 185°F, circulated, and the inhibitor level tested. FAILURE TO DO SO WILL RESULT IN DAMAGE to your furnace's water jacket!

Carefully follow the steps in your Owner's Manual for adding water and testing inhibitor levels.



The Online Support Center at support.woodmaster.com allows you to access the Owner's Manual and view videos and other resources specific to your furnace.

support.WoodMaster.com

pin 7000244

MAINTENANCE SCHEDULE

DAILY
Stir and scrape ashes in firebox. Move shaker grates. Remove ashes in ash pan as needed. Check water level.

MONTHLY
Check door rope; check chimney; check vent cap; clean and remove ashes.

BIANNUALLY
Clean firebox, flue, chimney and remove all ashes for inspection.
Cover chimney and clean out all ashes when not in use. DO NOT USE WASTE OIL.

READ OWNER'S MANUAL FOR COMPLETE INSTRUCTIONS

pin 7001339

WARNING

AVOID DAMAGE!
BEFORE operating this appliance read manual and watch videos for proper operation and maintenance procedures.

Damage or decreased life expectancy of appliance could result if appliance is not properly operated or maintained.

pin 7000508

Vent Cap Must Fit Loosely

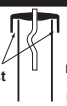

Le clapet d'aération doit recouvrir sur l'orifice sans forcer

CAUTION

Remove and discard wire from vent cap before filling or operating furnace. Never restrict venting or damage could occur.

ATTENTION

Retirer et jetez la bande de la bouche d'aération avant de remplir la chaudière d'eau. Ne restreignez la bouche d'aération ou des dommages pourraient survenir.

pin 7001003

NOTICE

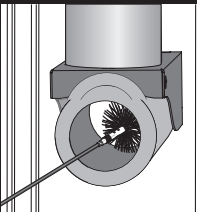

Initially, inspect the chimney transition weekly until you can determine the frequency of cleaning based on your application. Refer to the Owner's Manual for cleaning procedures.

1. Turn off power to the furnace.
2. Remove the chimney inspection cover.
3. Use brush to loosen soot and ash.

pin 7000000

NOTICE

Chimney pipe and all extensions must be insulated.

CAUTION

HOT Surfaces
Do NOT Touch During Operation

REMARQUE

Coupez l'alimentation électrique avant d'enlever ce panneau.

ATTENTION

Surfaces BRÛLANTES
NE touchez PAS pendant le fonctionnement

pin 7000240

Furnace Power Disconnect
Coupeur électrique de la chaudière.

NOTICE

To reset the circuit breaker, turn the switch OFF and then ON.

pin 7000348

WARNING

Risk of fire. Do not store fuel or other combustible materials within marked clearances to combustibles. Do not cover supply and return lines with combustible materials.

AVERTISSEMENT

Risque d'incendie. Ne stockez pas de carburant ou autres matériaux combustibles à l'intérieur du périmètre de sécurité indiqué. Ne recouvrez pas les conduites d'alimentation et de retour avec des matériaux combustibles.

pin 7000243

NOTICE

For use with aluminum or copper conductors.

REMARQUE

Pour utilisation avec des conducteurs en aluminium ou en cuivre.

pin 7000247

WARNING

Risk of fire or explosion. Follow proper opening instructions for ash removal and cleaning. Do not leave open unattended or runaway fire may result.

AVERTISSEMENT

Risque d'incendie ou d'explosion. Suivez les instructions d'ouverture appropriées pour l'enlèvement des cendres et le nettoyage. Ne laissez pas la porte de l'enlèvement des cendres ouverte sans surveillance ou feu emballement peut résulter.

pin 7000000

FURNACE MEASUREMENTS

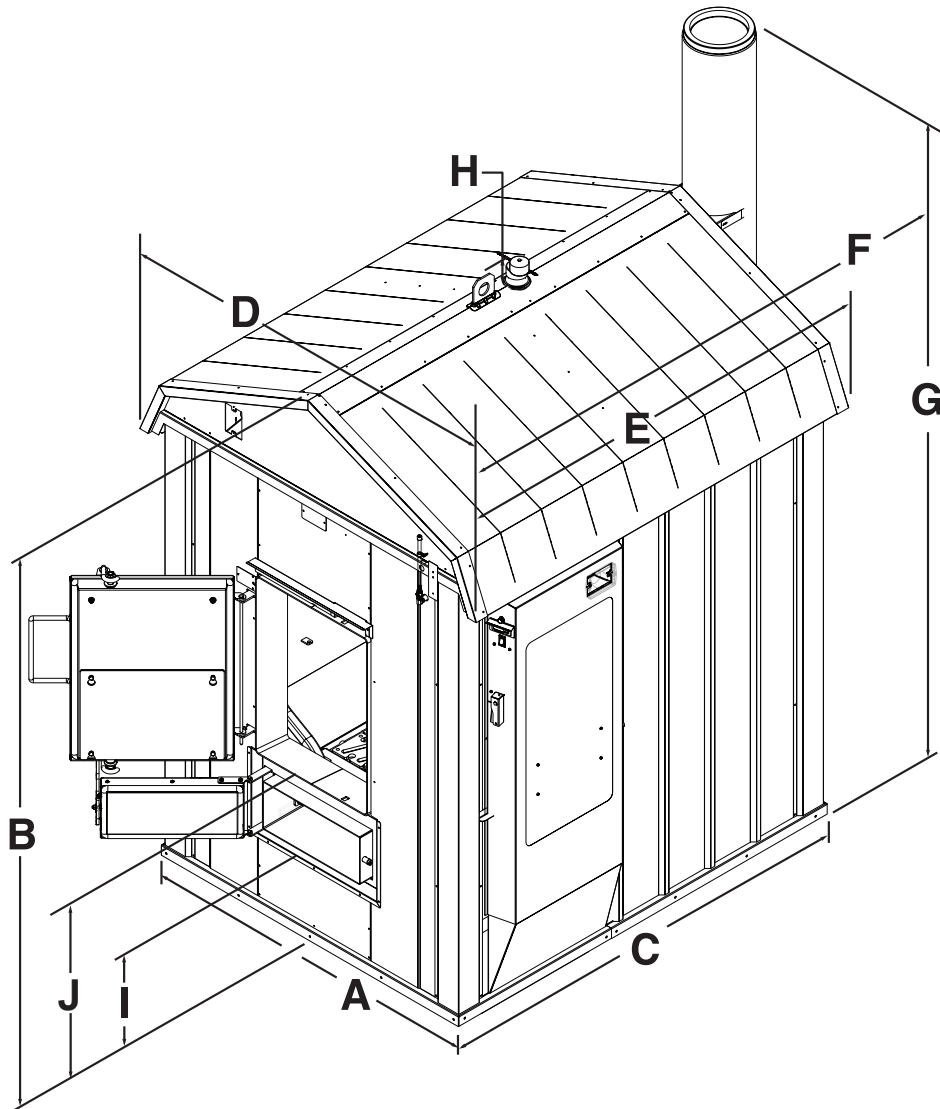

FURNACE MEASUREMENTS										
	A	B	C	D	E	F	G	H	I	J
FireMax 5000	47"	79"	63"	51"	64"	76"	105"*	4"	14"	26.5"
FireMax 6000	59"	93"	73"	65"	74"	86"	116"*	4"	14"	26.5"

* Measurement includes one chimney section.

WIRING DIAGRAMS

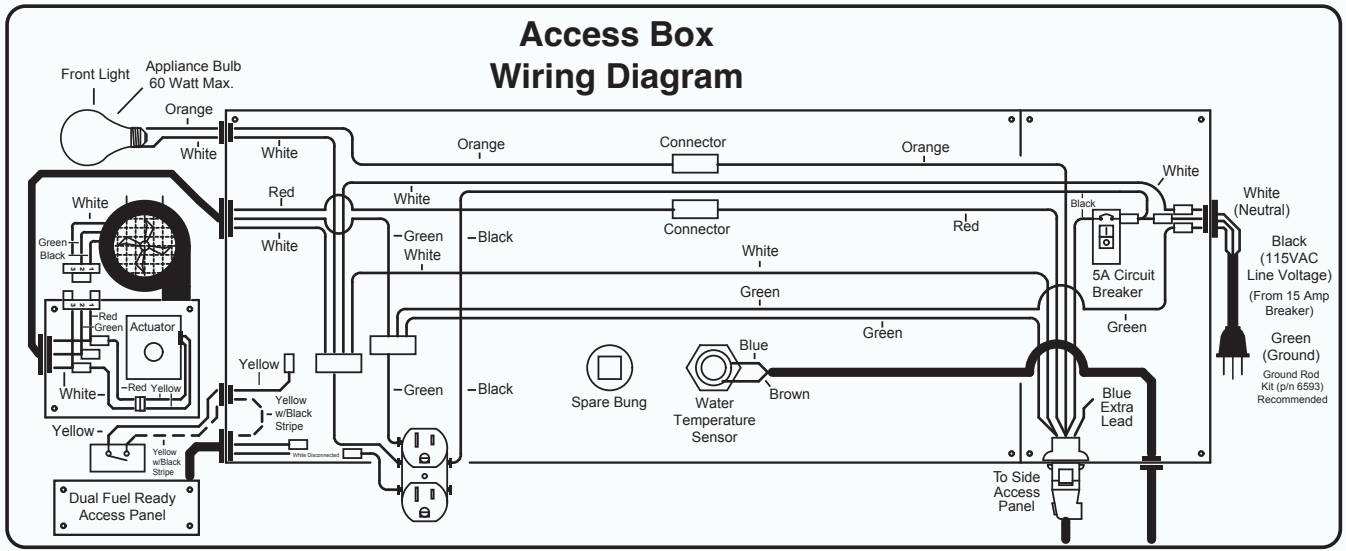

p/n 7001317 Rev. C

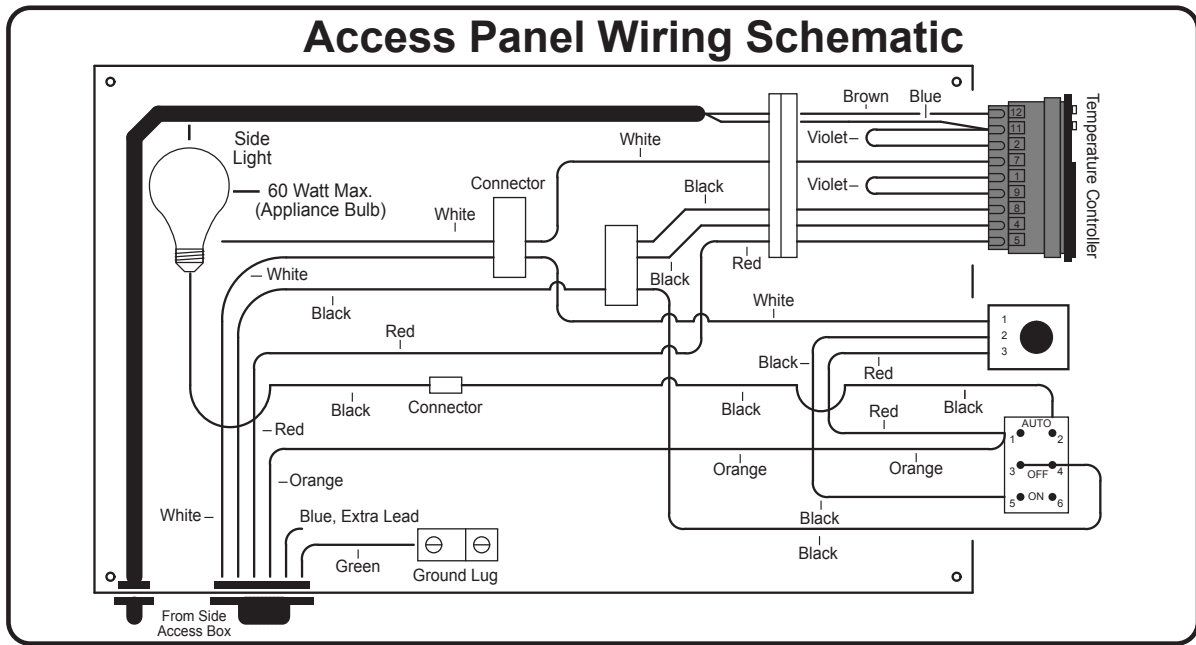

⚠ WARNING
Disconnect power before removing this panel.

⚠ AVERTISSEMENT
Coupez l'alimentation électrique avant de retirer ce panneau.

⚠ WARNING
Remove strapping over vent cap before filling or operating furnace.

⚠ AVERTISSEMENT
Avant de remplir ou d'utiliser la chaudière, retirez la bande qui passe par-dessus le clapet d'aération.

NOTICE

To Start Up (or Reset) Furnace — press the SET button one time.

Parameter Descriptions and Factory Settings
Set (setpoint) - 185°F
Hy (Differential) - 2°F
ALL (Low Alarm) - 120°F

How to View Setpoint — Push and immediately release the SET button. The display will indicate setpoint and will return to water temperature after five seconds.

How to Reset LA or ALL — If the display indicates LA or ALL, the water temperature has dropped to the Low Alarm setting. Reset by pressing the SET button.

How to Change the Setpoint — Push and hold the SET button until the setpoint is displayed. Change the value using the UP and DOWN Arrow buttons, select the parameter to be changed (Hy or ALL), push the SET button once (value of parameter should be displayed), use UP and DOWN Arrow buttons to change the value, and push the SET button (value should flash a few times). After 10-15 seconds the display will change back to water temperature.

How to Change Hy or ALL — Push and hold the SET and DOWN Arrow buttons at the same time until HY is displayed. Using the UP and DOWN Arrow buttons, select the parameter to be changed (Hy or ALL), push the SET button once (value of parameter should be displayed), use UP and DOWN Arrow buttons to change the value, and push the SET button (value should flash a few times). After 10-15 seconds the display will change back to water temperature.

NOTICE

ATTENTION! IMMEDIATE ACTION REQUIRED

Add MolyArmor 350 Corrosion Inhibitor IMMEDIATELY before filling with water.

FIREMAX MODELS
FIREMAX 5000 - 1.5 units
FIREMAX 6000 - 2.5 units

After filling the system, IMMEDIATELY heat the system water to 185°F and start the pump(s) to circulate water in the system.

Read the Owner's Manual for more information about testing the system water and submitting water samples to be certain that proper MolyArmor 350 and pH levels are achieved.

WATER SAMPLE INFORMATION - TITANIUM SERIES MODELS

NOTE: It is your responsibility as owner to ensure that your water sample information is accurate and that you submit your samples on a timely basis as required by the warranty for your stainless steel outdoor furnace. Failure to do so will result in a one year warranty.

WATER SAMPLE LABEL INFORMATION

Use the Water Sample Kit provided in your owner's packet or make a copy of the water sample label below, attach the **COMPLETED** label to the water sample bottle, and mail your water sample to WoodMaster.

NAME: _____			
ADDRESS: _____			
CITY: _____		STATE: _____	ZIP: _____
EMAIL: _____			
PHONE: _____		FURNACE SERIAL # _____	
DEALER: _____			
DATE SAMPLE COLLECTED: _____			
<input type="checkbox"/> NO ANTIFREEZE ADDED		<input type="checkbox"/> ANTIFREEZE ADDED	
<i>Please check ONE box</i>			
FOR LAB USE ONLY:			
Moly	pH	Ni	Date

**Additional labels can be printed at
WoodMaster.com/w25
(scan the QR code to visit
the page, then enter your serial
number and postal code)**

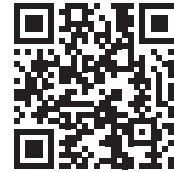

MAILING LABEL

Use the Water Sample Kit provided in your owner's packet or send water samples to WoodMaster, Attn: Water Quality Department, 20502 160th Street, Greenbush, MN 56726.

FROM	_____

WOODMASTER, INC. ATTN: WATER QUALITY DEPARTMENT 20502 160th Street Greenbush, MN 56726	

NOTES

NOTES

WARRANTY COVERAGE

The warranty obligations of WoodMaster, Inc. ("WoodMaster") are strictly limited to the terms, conditions, limitations and exclusions set for in these warranties:

Limited One-Year Warranty - WoodMaster, Inc. ("WoodMaster") warrants to the original Owner, WoodMaster CleanFire, FireMax and Traditional Titanium Series outdoor furnaces against defects in workmanship for a period of ONE (1) YEAR from the date of original retail purchase provided that the Owner strictly complies with instructions in the Owner's Manual. The controller is covered for workmanship defect failures for two (2) years from the furnace purchase date.

If failure of a warranty-covered part occurs that is caused by a defect in workmanship, WoodMaster will, at its option:

1. repair or replace (using new or refurbished replacement parts) the defective or failed part; or
2. exchange the furnace with a comparable model furnace that is new or manufactured from new or serviceable used parts and is at least functionally equivalent to the original furnace.

Optional Limited 25-Year Extended Warranty - WoodMaster provides the original Owner with an Optional Limited Twenty-five (25) Year Extended Warranty from the original retail purchase date of the furnace provided that all qualifying requirements are met.

Optional Limited 25-year Extended Warranty coverage:

If a failure of the welded firebox/water jacket occurs that is caused by a defect in workmanship or corrosion, WoodMaster shall, at its sole discretion, elect one of the following remedies:

1. Repair or replace (using new or refurbished replacement parts) the defective or failed portion of the welded firebox/water jacket based on the date of original retail purchase, according to the following prorated scale:
 - Years 1-5: Parts and labor covered at 100%
 - Year 6: Parts covered at 70%
 - Year 7: Parts covered at 60%
 - Year 8: Parts covered at 50%
 - Year 9: Parts covered at 40%
 - Years 10-20: Parts covered at 15%
 - Years 21-25: Parts covered at 10%
2. Exchange the furnace with a comparable model furnace that is new or manufactured from new or serviceable used parts and is at least functionally equivalent to the original furnace; or
3. Provide a discount off of the retail purchase price of a new WoodMaster furnace of comparable model based on the pro-rated scale: Years 1-5: 100%; Years 6-7: 50%; Years 8-10: 40%; Years 11-15: 30%; Years 16-25: 10%.

Any replacement furnace or part provided under this warranty assumes the remaining warranty of the original furnace or part for ninety (90) days from the date of replacement or repair, whichever period provides longer coverage. As a condition of any replacement or remedy under this limited warranty, WoodMaster may, at its sole discretion, require the return of the replaced furnace or part to WoodMaster for inspection, recycling, or disposal. Wear parts, electrical parts, and other parts that are not welded to the firebox/water jacket are excluded from this extended warranty.

Optional Limited 25-year Extended Warranty qualifying requirements:

1. The Limited Warranty Registration Form must be fully completed and sent to WoodMaster within seven (7) days of the original Owner taking possession of the furnace otherwise this Optional Limited 25-year Extended Warranty will not be in effect.
2. The Owner must strictly comply with the instructions set forth in the Owner's Manual; otherwise, this Optional Limited 25-year Extended Warranty will not be in effect. Without limitation, the Owner must maintain Manufacturer-Approved Corrosion Inhibitor at the proper concentration, as it is imperative to preventing corrosion and is an essential condition of coverage. In addition, the Owner must submit a Furnace water sample to WoodMaster when the Furnace is initially placed into service and annually thereafter to verify compliance with maintenance and corrosion inhibitor requirements. This extended warranty will not be in effect, and no warranty claim can be approved unless all required water test verifications are on file at WoodMaster. In the absence of valid water test results on file with WoodMaster demonstrating continuous compliance with required corrosion inhibitor levels, it shall be conclusively presumed that the corrosion inhibitor levels were not properly maintained, and all warranty coverage for corrosion, defects, failures, or damage of any kind shall be denied.

EXCLUSIONS AND LIMITATIONS - These Limited Warranties apply only to WoodMaster CleanFire, FireMax and Traditional Titanium Series outdoor furnaces. These limited warranties cover only those defects or corrosion failures that arise as a result of normal use of the outdoor furnace and does not cover any other defects or problems, including those resulting from: (a) improper maintenance; (b) operation outside the furnace's specifications (see owner's manual), accident, abuse, misuse, misapplication, or parts that are not factory-installed; (c) service performed by anyone other than WoodMaster, unless authorized by WoodMaster in writing; (d) modifications undertaken without the written permission of WoodMaster; or (e) if any WoodMaster serial number has been removed or defaced.

The optional limited extended warranty shall be void if the Owner fails to maintain the proper amount of Manufacturer-Approved Corrosion Inhibitor in the system, fails to submit water samples to WoodMaster as required, or burns materials in the firebox other than the recommended fuels listed in the Owner's Manual.

This standard One-year Limited Warranty and the Optional Limited 25-year Extended Warranty exclude the cost of shipping, labor required to remove or reinstall the furnace, plumbing labor and/or parts and the cost of alternative heat if the furnace is out of service for repairs. Both warranties exclude replacement of water, corrosion inhibitors or other additives, and parts used in the system whether or not mounted on the furnace including without limitation, pumps, valves, and piping.

WoodMaster is not liable for damage or repairs required as a consequence of faulty installations or applications by others or any event of *force majeure*. WoodMaster further shall not be liable for incidents or accidents which can be prevented by the Owner or that occur from the operation of the outdoor furnace. A backup heating system should be in place to prevent damage in case of failure to refuel the outdoor furnace or in the event that mechanical failure of the outdoor furnace or system occurs. Heat replacement representations found in WoodMaster promotional information should be used only as a guideline. Heat loss for all applications with all weather extremes and other heat variables must be considered when sizing an outdoor furnace for different applications.

THESE LIMITED WARRANTIES AND REMEDIES SET FORTH ABOVE ARE EXCLUSIVE AND IN LIEU OF ALL OTHER WARRANTIES, REMEDIES AND CONDITIONS, WHETHER ORAL OR WRITTEN, EXPRESS OR IMPLIED. WOODMASTER SPECIFICALLY DISCLAIMS ALL IMPLIED WARRANTIES, INCLUDING, WITHOUT LIMITATION, WARRANTIES OF MERCHANTABILITY AND FITNESS FOR A PARTICULAR PURPOSE. TO THE EXTENT IMPLIED WARRANTIES CANNOT BE LAWFULLY DISCLAIMED, SUCH WARRANTIES SHALL BE LIMITED IN DURATION TO THE DURATION OF THESE LIMITED WARRANTIES.

No WoodMaster dealer or employee is authorized to modify, extend, or add to these limited warranties. WOODMASTER IS NOT RESPONSIBLE FOR DIRECT, SPECIAL, INCIDENTAL OR CONSEQUENTIAL DAMAGES RESULTING FROM ANY BREACH OF WARRANTY OR CONDITION, OR UNDER ANY OTHER LEGAL THEORY. Some states or provinces do not allow limitations on the duration of implied warranties or conditions, or the exclusion or limitations of incidental or consequential damages; therefore, the above limitations or exclusions may not apply to you. These warranties provide specific legal rights, and you may have other rights that vary by state or province.

OBTAINING WARRANTY SERVICE - To obtain warranty service, contact the WoodMaster dealer from whom you purchased your furnace or contact WoodMaster by telephone (218-782-3419) or by mail at 600 Polk Ave. SW, Red Lake Falls, MN 56750. Please provide the dealer's name, original date of sale, model number and serial number in all communications. WoodMaster reserves the right to require the warranty service to be performed at a WoodMaster facility when deemed necessary by WoodMaster. All corrosion repairs will be performed at WoodMaster unless authorized in writing by WoodMaster.

Design Changes. WoodMaster reserves the right to change and improve the product design for improved performance without assuming responsibility to upgrade previously sold products.