

WOODMASTER®

OUTDOOR WOOD FURNACE

OWNER'S MANUAL



6500

TITANIUM
HEAVY DUTY

**IN THE U.S., THIS APPLIANCE
IS FOR NON-RESIDENTIAL
APPLICATIONS ONLY**

**Retain this manual/
Conservez ce manuel**

WoodMaster.com

(p/n 9000939 - REV. D) - APR 2026



WoodMaster, Inc. • 600 Polk Ave. SW • Red Lake Falls, MN 56750
WoodMaster.com

WOODMASTER ONLINE RESOURCES

Enter **WoodMaster.com** in your browser or scan the code using any QR code reader app on your smartphone to access WoodMaster's library of information to help with installation, operation and maintenance of your WoodMaster outdoor furnace.

Detailed Furnace Installation Variations - <https://www.woodmaster.com/furnace-installation/>

View and/or download PDFs to assist in installation of your outdoor furnace. Information and examples regarding pumps, foundations, chimneys and support structures, ThermoPEX piping, and example configurations for a variety of heating configurations.



Online Support Center

<https://support.woodmaster.com>

Enter your furnace serial number and find articles, answers, parts and more information.

Online Support Center
support.WoodMaster.com
Enter your serial number for information specific to your furnace.
Write your *serial number* here for future reference.

EPA RESOURCES

EPA's Burnwise Program - <https://www.epa.gov/burnwise>

How to Use a Moisture Meter Video - <http://www.youtube.com/watch?v=jM2WGgRcnm0>

EPA offers tips on how to properly use a moisture meter to test firewood before using in a wood-burning stove or fireplace. Wet wood can create excessive smoke which is wasted fuel.

Split, Stack, Cover and Store Video - <http://www.youtube.com/watch?v=yo1--Zrh11s>

EPA offers four simple steps to properly dry firewood before using in a wood-burning stove or fireplace. Wet wood can create excessive smoke which is wasted fuel. Burning dry, seasoned firewood with a moisture content of 20% or less can save money and help reduce harmful air pollution.

Resources to Help Burn Wood the Right Way - <https://www.epa.gov/burnwise/resources-help-you-burn-wood-right-way-and-promote-burn-wise-program>. Find tip sheets, brochure and flyers, and more information.

NOTE: The warranty can be voided by operating a residential hydronic heater in a manner inconsistent with the Owner's Manual.

For parts and accessories, service or repairs, call your authorized WoodMaster dealer or heating contractor. Record the information below for future reference.

Model	Serial Number	Installation Date
Dealership Name		Phone Number
Owner Name		

Contents

How to Use This Guide

The guide is divided into sections to help with the operation and maintenance of the outdoor furnace. If questions arise that are not answered with this manual, consult with your authorized WoodMaster dealer.

WoodMaster Online Resources	li
EPA Resources	li
Labeling and Terminology	1
Safety - Important Safety Instructions	2
Pre-Installation Precautions	2
Planning the Location	5
Chimney Specifications	5
Block or Pad Supports	6
Digging the Trench	7
Underground Electric Wire	7
Supply and Return Lines	8
Temporary Above Ground or Winter Installations	8
Mounting the Pump	9
Wiring the Pump	10
Connecting Water Lines	10
Entering the Building	11
Inline Filter and Fill Valve Assembly	11
Furnace Installation - Connecting to Your Existing System	11
Domestic Hot Water	11
Existing Hot Water Heat	12
Existing Forced Air	12
WATER QUALITY AND MAINTENANCE	13
Test Supply Water	13
Adding Initial Water Treatment	13
Filling with Water	14
Bleeding the System	14
Immediately Start the Pump(s); then Heat the System Water to 170°F (76°C)	14
Test the Treated System Water	15
Send in Initial Water Sample	16
Annual Water Sample	16
Water Samples	17
System Maintenance	17
Water Test Kits and Test Results	17
Adding Antifreeze to Outdoor Furnace System	18
Wood Selection and Preparation	19
Operating Instructions	20
Firing the Furnace	20
Loading the Furnace	21
Maintenance	22
Routine Maintenance	23
Maintenance Sections	23
Troubleshooting	26
Electronic Temperature Control (ETC) Guide	29
ETC Reference	30
Changing ETC Settings	36
Wiring Diagrams	37
Technical Specifications	38
Water Sample Information - Traditional Models	39
Limited Warranty	Back Cover

OUTDOOR WOOD FURNACE BEST BURN PRACTICES

1. Read and follow all operating instructions supplied by the manufacturer.
2. **FUEL USED:** Burn only split and seasoned wood with 25% moisture content or less. DO NOT burn green wood. Never use the following: trash, plastics, gasoline, rubber, naphtha, household garbage, material treated with petroleum products (particle board, railroad ties and pressure treated wood), leaves and cardboard. Paper products should only be used when firing your furnace.
3. **LOADING FUEL:** For a more efficient burn, pay careful attention to loading times and amounts. Follow the manufacturer's written instructions for recommended loading times and amounts.
4. **STARTERS:** Do not use lighter fluids, gasoline, or chemicals. Use paper products and kindling only.
5. **LOCATION:** It is recommended that the unit be located with due consideration to the prevailing wind direction.
 - When using more than 4 feet of chimney extension, external support is needed.
 - Must be located at least 25 feet from the property line.
 - Furnace should be located no less than 100 feet from any residence not served by the furnace.
 - If located within 100 feet to 300 feet to any residence not served by the furnace, it is recommended that the stack be at least 2 feet higher than the peak of that residence.

Chimney Height Installation Scenario

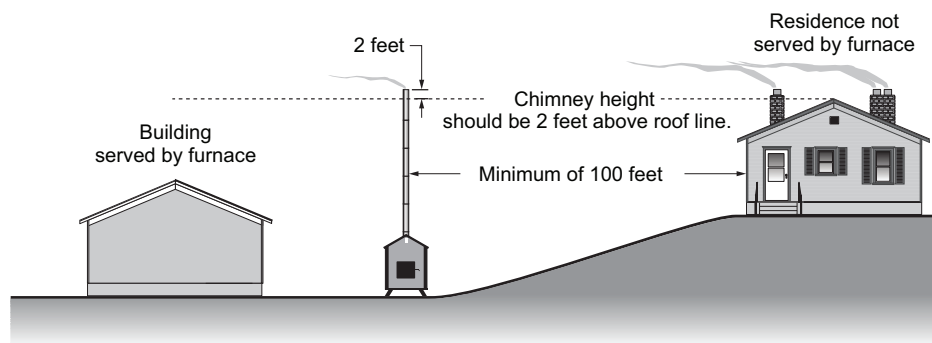

6. Always remember to comply with all applicable state and local codes.



OUTDOOR FURNACE MANUFACTURERS CAUCUS

INSTALLATIONS IN MASSACHUSETTS:

1. All installation components must be products approved in the Commonwealth of Massachusetts by the Gas and Plumbing Board.
2. The maximum run of tubing from the water heater to a fan coil is 50 linear feet.
3. Persons operating this hydronic heater are responsible for operation of the hydronic heater so as not to cause a condition of air pollution as defined in 310 CMR 7.01(1).

Labeling and Terminology

The outdoor furnace and this installation guide use the following terms and symbols to bring attention to the presence of hazards of various risk levels and important information concerning the use and maintenance of the outdoor furnace.

DANGER

This symbol and text indicate an imminently hazardous situation which, if ignored, will result in death or serious injury.

WARNING

This symbol and text indicate the presence of a hazard which can cause severe personal injury or death to an operator or bystander, or substantial property damage if ignored.

CAUTION

This symbol and text indicate the presence of a hazard which can cause minor personal injury or property damage if ignored.

NOTE: Indicates supplementary information worthy of particular attention relating to installation, operation, or maintenance of the outdoor furnace but is not related to a hazardous condition.

Be sure to follow all instructions and related precautions as they are meant for your safety and protection. Store this manual in a readily accessible location for future reference.

Safety - Important Safety Instructions

Be sure to read carefully and understand these precautions before, during and after the installation, operation and maintenance of the furnace.

NOTE: READ ALL INSTRUCTIONS BEFORE INSTALLATION.

Pre-Installation Precautions

⚠ CAUTION

All installation and operations must follow **STATE and LOCAL CODES** for wiring, plumbing, and firing of this unit. These **CODES** may differ from this manual. Installation must be performed by a Qualified Installer.

⚠ CAUTION

Read and follow these directions carefully. Retain this manual for as long as you own your WoodMaster.

⚠ CAUTION

All WoodMaster models operate at atmospheric pressure. **DO NOT** obstruct, block, or plug in any way the overflow vent pipe which is located directly behind the chimney on top of the furnace.

⚠ CAUTION

The WoodMaster is designed for outdoor use. We do not recommend installing in a building.

⚠ CAUTION

Manufacturer recommends a minimum 25 foot clearance from buildings or fire hazards. If placed near a fire hazard area an approved spark arrester should be used.

⚠ CAUTION

Only responsible adults should operate your furnace. If furnace is not fired properly damage could result and the warranty be voided.

⚠ CAUTION

Never allow small children to play near or tamper with furnace. Always keep the area around, and in front of fuel door clean and free from combustible materials.

⚠ CAUTION

Do not connect this unit to a chimney flue serving another appliance.

⚠ CAUTION

Load wood carefully to avoid injury to hands and fingers that may come into contact with furnace opening.

⚠ CAUTION

Pump must run continuously whenever the WoodMaster is being used.

⚠ CAUTION

Cut split seasoned wood is the recommended fuel (approximately 25% moisture or less).

IMPORTANTES INSTRUCTIONS DE SÉCURITÉ

LISEZ TOUT CES INSTRUCTIONS AVANT L'INSTALLATION.

Précautions à prendre avant l'installation

⚠ PRÉCAUTIONS À PRENDRE

Toutes installations et opérations doivent être faites en accord aux réglementations en force dans votre localité, province ou état pour le câblage électrique, la plomberie et l'opération de cette unité. Ces réglementations peuvent différer de celle de ce manuel. L'installation doit être entreprise par un Technicien Qualifié.

⚠ PRÉCAUTIONS À PRENDRE

Lisez et suivez attentivement ces directions. Conservez ce manuel aussi longtemps que vous posséderez votre WoodMaster.

⚠ PRÉCAUTIONS À PRENDRE

Tous les modèles WoodMaster s'opèrent à la pression atmosphérique. NE PAS boucher ou créer d'obstructions qui pourraient restreindre le débit du tuyau de surcharge situé directement à l'arrière de la cheminée en haut de foyer.

⚠ PRÉCAUTIONS À PRENDRE

Le WoodMaster a été conçu pour être utilisé à l'extérieur. Nous ne recommandons pas qu'il soit installé à l'intérieur d'un bâtiment.

⚠ PRÉCAUTIONS À PRENDRE

Il est recommandé par le fabricant qu'une distance minimale de 25 pieds entre le foyer et tout bâtiment ou zone inflammable. Si placé à proximité d'une zone inflammable, une barrière anti-étincelles doit être utilisée.

⚠ PRÉCAUTIONS À PRENDRE

L'opération de la chaudière doit être restreinte aux adultes responsables. Si la chaudière n'est pas opérée correctement, elle risque d'être endommagée et la garantie serait annulée.

⚠ PRÉCAUTIONS À PRENDRE

Ne jamais permettre aux enfants de jouer à proximité ou de toucher la chaudière. Gardez toujours les alentours et l'avant de la porte propre et sans matériaux combustibles.

⚠ PRÉCAUTIONS À PRENDRE

Ne pas connecter cette unité à une cheminée utilisée par un autre équipement.

⚠ PRÉCAUTIONS À PRENDRE

Faites attention à vos mains et doigts en mettant le bois au four afin d'éviter de les coincer entre le bois et les bords de la porte.

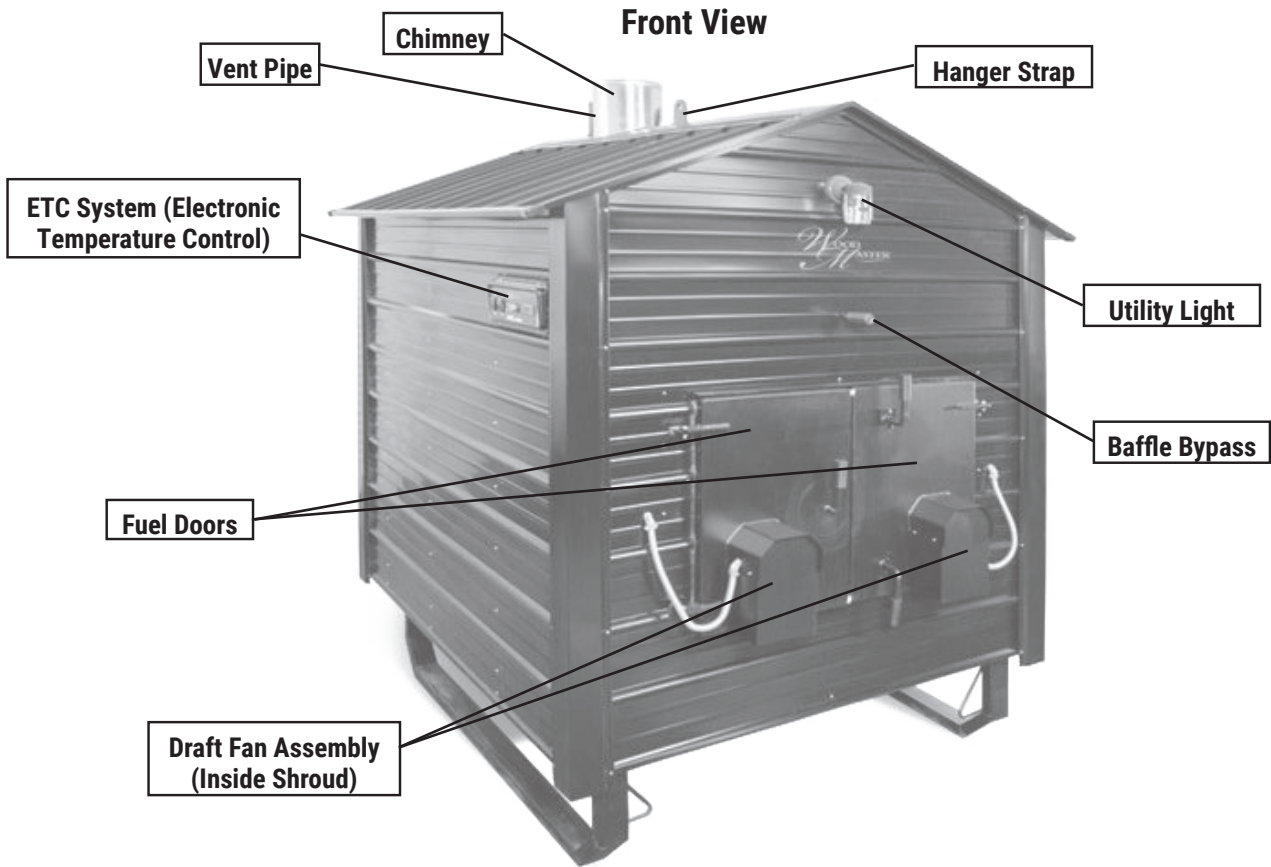

Rear Panel

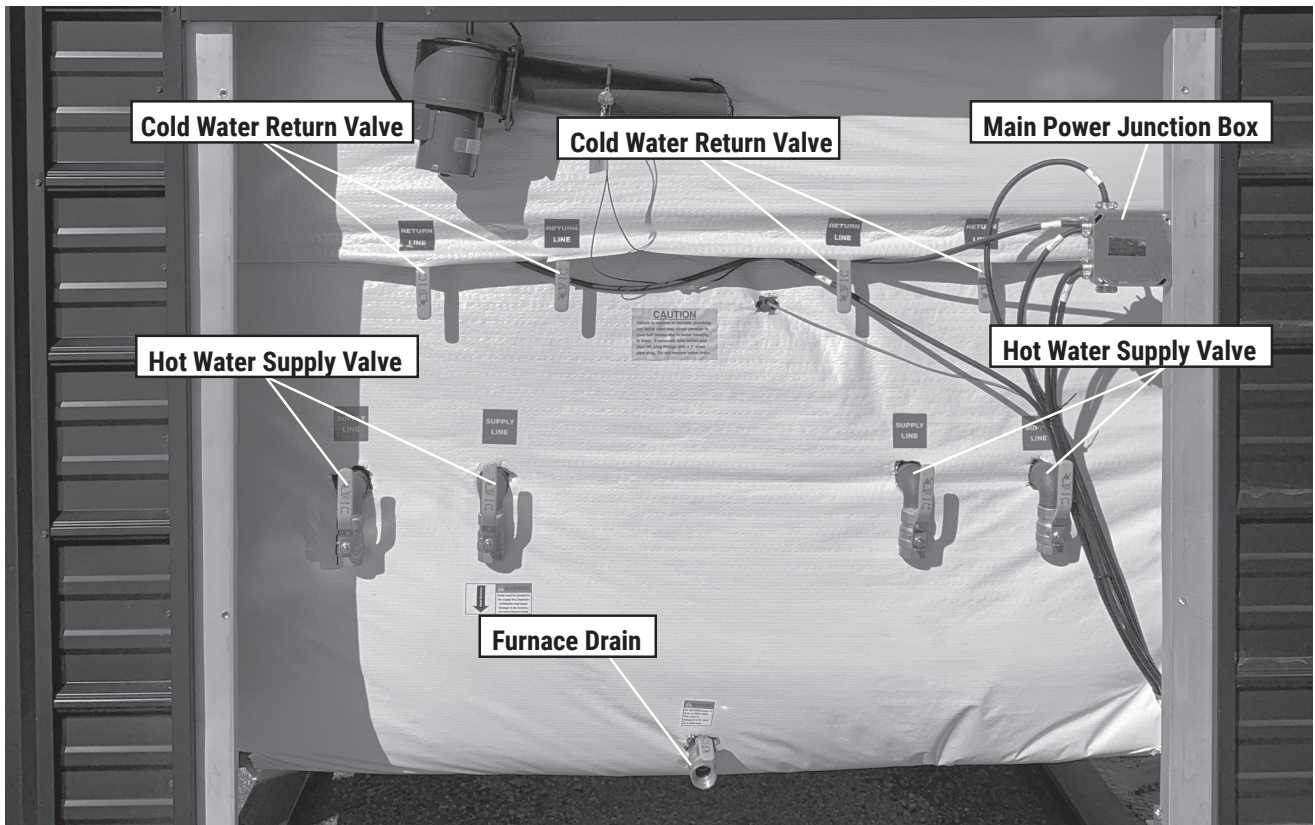

Planning the Location

When selecting a suitable location, carefully consider each of the following:

- The WoodMaster is designed for outdoor use. We do not recommend installing in a building. When installing your WoodMaster, keep in mind the direction of the winds during heating months. Try to place the furnace in an area where exhaust will not be a problem for yourself or any surrounding neighbors. For commercial use only, not to be connected to a residence.
- Must be installed in accordance to all applicable codes and regulations.
- Check with your insurance company to see if they have any location requirements.
- Consider prevailing winds and the direction smoke will travel.
- The shorter the distance between the outdoor furnace and building(s) being heated, the lower the cost will be for the installation of the hot supply and return water lines, and ThermoPEX insulation.
- Be sure to maintain the required clearances to combustibles and recommended maintenance clearances.
- ThermoPEX pre-insulated piping is recommended for all installations. Other types of insulated pipe configurations may result in high heat loss and increased wood consumption.
- If the ground at the location is unstable or subject to frost heaving, consider installing 2" (5 cm) closed-cell insulation under the front portion of the concrete slab the outdoor furnace will be installed on, and under the area around the slab used for walking. Your Owner's Manual has more information about foundations and foundation dimensions.

Chimney Specifications

To insure proper insulation, use only a Class A Insulated Chimney and Chimney Adapter from your local WoodMaster Dealer.

⚠ CAUTION

Using a non-insulated chimney or failure to use a Class A Insulated chimney WILL result in a voided warranty.

Foundation Advantages

Installing the outdoor furnace on a foundation offers many advantages. The outdoor furnace is less likely to move due to frost heaving. A foundation keeps the area directly around the outdoor furnace free of standing water. It can also raise the furnace up to provide a more comfortable height of the firebox door opening.

Block or Pad Supports

Under normal conditions four cement blocks are all that is required to support the furnace. Blocks should be at least 6 inches wide, 10 inches long, and 3 inches thick.

Under very soft conditions a concrete pad may be needed. To install the outdoor furnace on a concrete foundation, refer to the illustration for dimensions and for the location of the hollowed-out area for each model. A 4" to 6" (10 to 15 cm) thick concrete slab works well; however, a thicker slab may be used to obtain the desired door opening height. Always use a non-combustible base.

If the area for the concrete slab is unstable and/or affected by frost heaving, consider installing 2" closed-cell insulation beneath the front portion of the slab and under the area of the ground used for walking.

⚠ CAUTION

CALL BEFORE YOU DIG. Do not use any combustible materials for the foundation.

NOTE: The installation surface or foundation must be noncombustible. The hot supply and return lines must also be protected from possible exposure to sunlight, fire or physical damage that may be caused by an occurrence outside the outdoor furnace enclosure. Foundations may consist of concrete, crushed rock or patio blocks.

Slab Dimensions / Furnace Dimensions

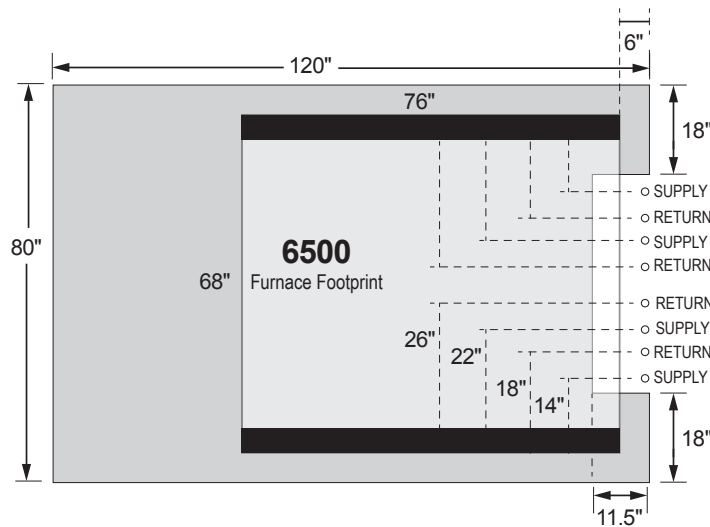

⚠ CAUTION
Do not use any combustible materials for the foundation.

Outdoor furnace must be installed on a noncombustible surface or foundation that incorporates an enclosure that will prevent supply and return lines from possible exposure to sunlight, fire, or physical damage that may be caused by an occurrence outside the outdoor furnace enclosure. Foundation may consist of concrete, crushed rock, or patio blocks.



ThermoPEX® Advantage

ThermoPEX is flexible pre-insulated piping that is ideal for use with outdoor wood furnaces. ThermoPEX consists of two 1-inch* oxygen barrier PEX® lines, two 1-1/4 inch** oxygen barrier PEX lines, or two 25mm*** oxygen barrier PEX lines (a supply and a return line). The lines are insulated with high-density urethane insulation and a thick, durable, waterproof polyethylene outer jacket. Thermal expansion is absorbed within the system because the PEX lines, urethane insulation and the durable outer jacket are cast together. The corrugated design allows flexing for easier installation. ThermoPEX is a proven product and maintenance-free.

*CTS ASTM 1" supply and return.

**SDR-11 ASTM 1-1/4" supply and return.

***SDR-11 ASTM 25mm supply and return.

Digging the Trench

⚠ WARNING

Before digging, be sure to call for utility locator service.

The trench depth for ThermoPEX should be between 10" and 28" (25 and 71 cm).

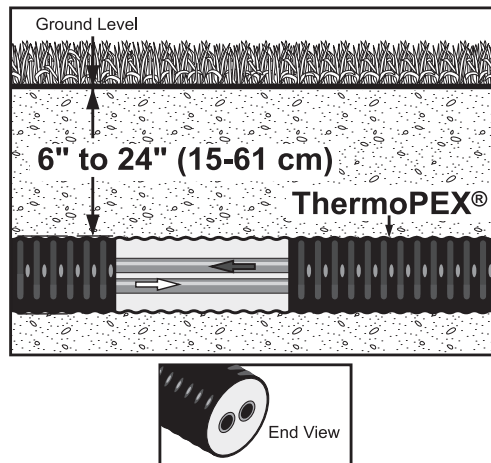

NOTE: Do not backfill the trench until the supply and return lines have been tested to ensure there are no leaks.

Underground Electric Wire

⚠ CAUTION

All wiring must follow state and local codes and should be done by a qualified electrician.

A 12-2 (two wires plus ground) underground rated wire should supply the outdoor furnace with electricity. A heavier gauge wire may be needed if the run is over 200 feet (61 meters). Check local codes and requirements. It is recommended that the incoming fuse or circuit breaker not exceed 15 amps.

Supply and Return Lines

Determine the configuration of the supply and return lines from the outdoor furnace to where the supply and return lines will connect to the existing heating system. WoodMaster recommends using the ThermoPEX® piping system.

ThermoPEX is a fully assembled, pre-insulated piping system consisting of two 1" Central PEX lines or two 1-1/4" PEX lines. The two lines (one a supply and one a return line) are insulated with high-density urethane insulation and a thick, durable, waterproof, polyethylene outer jacket. One of the lines is marked with a black stripe for identification.

NOTE: To prevent ground water from entering the house, do not use drain tile, PVC pipe with bubble wrap, or any other inferior material for insulating the water lines.

NOTE: If the outdoor furnace supply and return lines are not insulated properly, or if other brands of insulated piping are used, there can be excessive heat loss. This heat loss can greatly increase the fuel consumption.

NOTE: If it is unavoidable that the trench will run through an area of ponding water, use ThermoPEX instead of other materials. ThermoPEX should also be used for above-ground or winter installations, and if the area is likely to be affected by compaction.

Temporary Above Ground or Winter Installations

For temporary above ground or winter installations in which the supply and return lines can not immediately be buried underground, WoodMaster recommends using ThermoPEX. Be sure that both the insulation and the supply and return lines will not be exposed to ultraviolet rays. The ThermoPEX exterior jacket has UV protection but the insulation and water lines inside do not. Use a ThermoPEX termination cap at each end of the installation to protect and seal the insulation from water.

NOTE: Bury the ThermoPEX as soon as conditions permit (e.g., once the ground has thawed).

NOTE: If ThermoPEX is installed temporarily above ground, provisions should be made to prevent possible risk of fire coming into contact with the ThermoPEX. ThermoPEX is constructed of materials that can burn and transfer a fire.

⚠ CAUTION

If ThermoPEX is installed temporarily above ground, do not cover with combustible materials (e.g., straw, hay, leaves, etc.).

Mounting the Pump

1. Attach the 1" x 2" Black Nipple (0020-250) and one half of the flanges from the 1" Cast Iron Pump Flange Kit (194) to one of the hot water supply valves on back of furnace.
2. Locate one of the black rubber gaskets and place it between the pump and the mounted flange; then bolt the pump to the flange. Make sure the arrow on the pump indicating direction of water flow points down.
3. Bolt the remaining Flange and Gasket to the bottom of the Pump.

NOTE: Make sure that the pump is attached to the supply line, not the return.

NOTE: All threaded fittings must be cleaned and have pipe dope and/or tape applied prior to final installation.

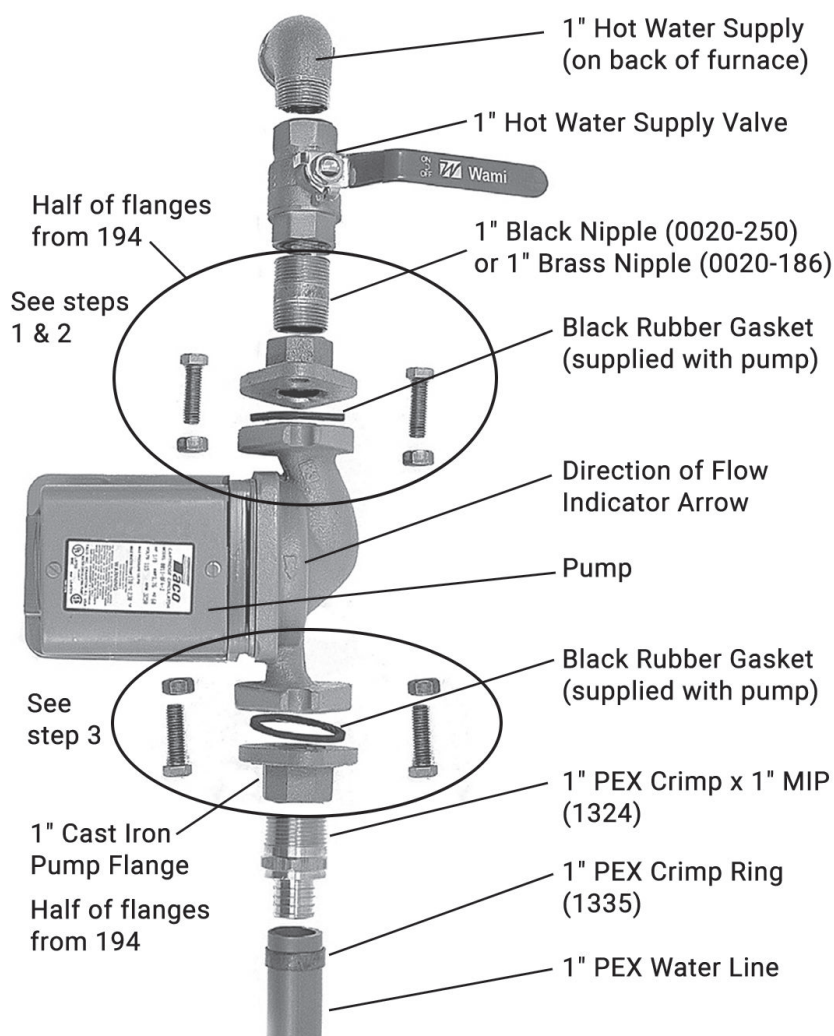

⚠ CAUTION

The pump must run continuously whenever the WoodMaster furnace is in use. It cannot be wired to thermostats that only run the pump when the building calls for it.

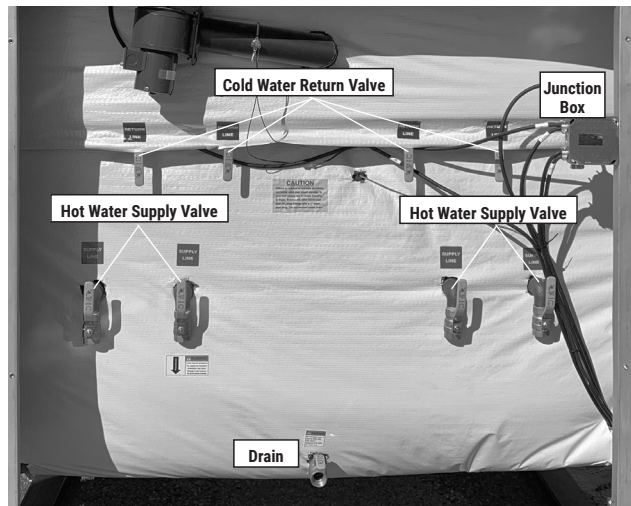

Wiring the Pump

⚠ CAUTION

Never run the pumps dry! The furnace must be full of water and the valves must be open.

⚠ CAUTION

Disconnect power before servicing any electrical components.

⚠ CAUTION

All wiring must follow state and local codes and should be done by a qualified electrician.

1. Remove the cover on the pump.
2. Using an approved wire, connect the ground wire to the green ground screw on the pump.
3. Connect the black wire to the yellow wire on the pump.
4. Connect the remaining two white wires together and replace the pump cover.
5. Locate junction box on back of furnace and remove the cover. Connect the running end of the approved wire coming from the pump to the junction.

NOTE: The wires from the pump will have to connect with the main power wires in the junction box along with the power wires from the ETC System.

Connecting Water Lines

Hot Water Supply

Attach the 1" PEX x 1" MIP fitting (1324) to the flange on the bottom of the pump. Then attach the hot water supply 1" PEX water line to the fitting using 1" PEX Crimp Ring (1335).

Cold Water Return

Attach the 1" PEX x 1" MIP fitting (1324) to the cold water return valve on the same side of the furnace on which the pump was attached. Then attach the cold water return 1" PEX water line to the fitting using 1" PEX Crimp Ring (1335).

NOTE: A 1" male Sharkbite Adapter (0020-510) may be substituted for the 1324 and 1335 fittings.

Entering the Building

Entering the building with water lines can be done underground or over the sill plate. Once inside the building the typical hookup would run first to the domestic hot water supply and next to an existing heating system such as a forced air furnace or a hot water heating system. Finally, before leaving the building, a fill valve should be installed near enough to a water supply for filling and flushing the WoodMaster furnace.

Inline Filter and Fill Valve Assembly

The Inline Filter and Fill Valve Assembly (0020-325) should be installed in the cold water return line before the line exits the building. It should be placed so that a garden hose can be connected between a domestic water supply and the fill valve.

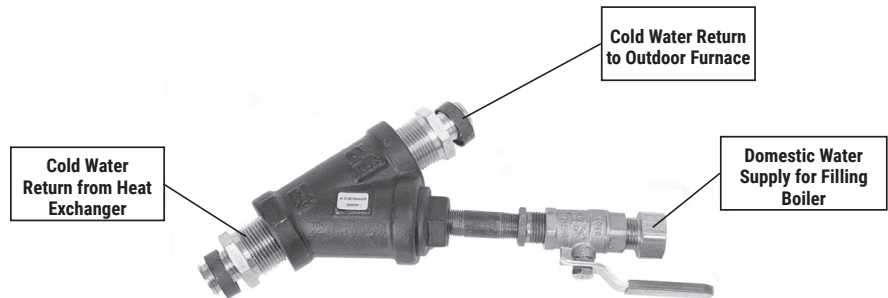

Furnace Installation - Connecting to Your Existing System

A common installation is to connect the outdoor furnace to an existing water heater and then to an existing forced air system.

NOTE: There are numerous ways to connect to your heating system. Refer to the Installation Guide for other installations.

Domestic Hot Water

The Domestic Hot Water/Flatplate Kit consists of a water-to-water heat transfer unit and the fittings needed to hook it up. The unit mounts on the wall VERTICALLY in your utility room and is connected as shown. Contact your WoodMaster dealer for proper plate size and fittings.

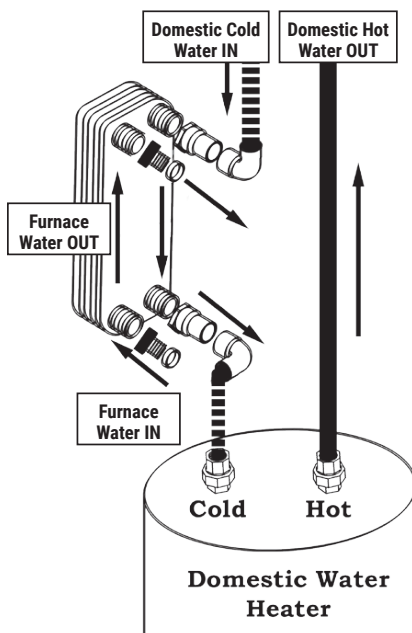

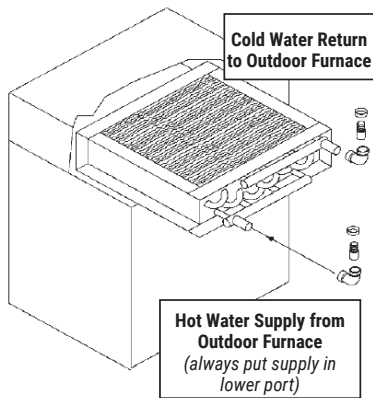

The heat exchanger works on the same principal as your car heater. Air blows through the heat exchanger, taking the heat from the water and blowing it into your existing duct work.

Existing Forced Air

A water-to-air heat exchanger is inserted in the existing plenum. In most cases the heat exchanger is placed in a horizontal position, keeping all four sides level. The air must be forced through the finned area of the heat exchanger evenly. The hot water line coming from the hot water tube enters the bottom fitting of the heat exchanger and exits the top fitting, which returns to the furnace. If the plenum is too large or too small, it must be altered to fit the heat exchanger properly.

NOTE: The water-to-air heat exchanger must be installed below any existing off-peak electric coils already in the plenum.

After the installation of the add-on water to air exchanger, the air flow may need to be increased to fuel furnaces, electric furnaces, and electric/gas furnaces. Methods of doing this are:

Belt Drive System - Blower pulleys and motor pulleys may be changed but the electric current flowing through the motor shall not exceed the nameplate rating. A blower motor or larger power may be used.

Direct Drive System - The motor shall not be changed, however the speed of the motor may be increased.

⚠ CAUTION

All wiring must follow state and local codes and should be done by a qualified electrician. Wire thermostats according to directions provided by the manufacturer.

Existing Hot Water Heat

A Water-to-Water Heat Transfer Unit (0020-052) is used to connect to an existing hot water boiler system.

NOTE: Any changes that are made to an existing boiler should be done by a qualified plumber and follow all state and local codes.

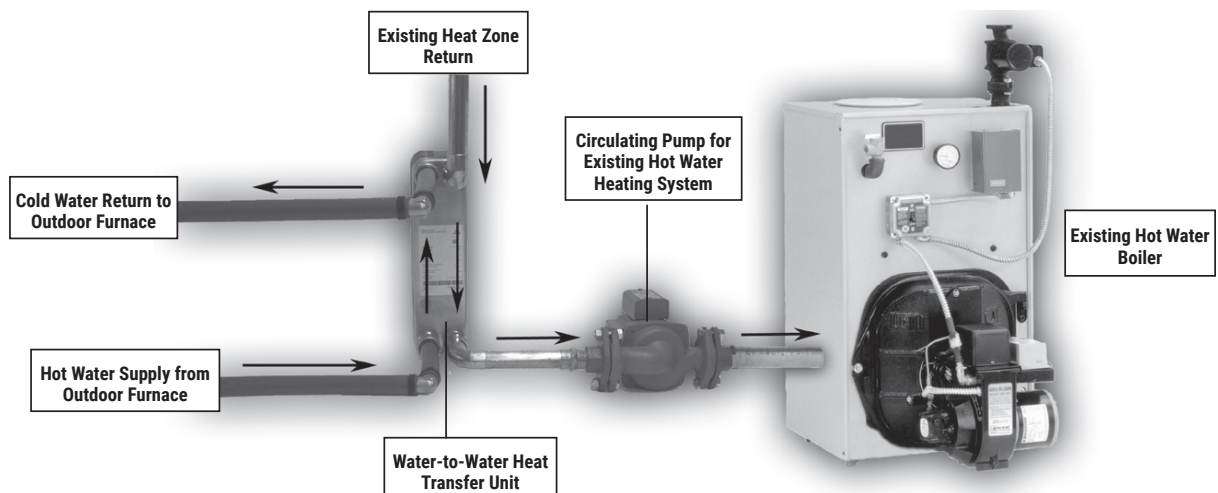

WATER QUALITY AND MAINTENANCE

Test Supply Water

Test a sample of the supply water (makeup water) that will be used to fill the outdoor furnace (softened water is recommended). Test strips for testing pH are included in the water test kit which is provided with the outdoor furnace.

1. Collect a small sample of the water to be used to fill the outdoor furnace in a clean container.
2. Dip a test strip from the test kit in the water sample for **1 second** and remove. Shake off excess liquid (very important to prevent water bleed from one pad to the other). Compare the pH test pad to the color chart at **30 seconds**.
3. If the pH level is between 6.5 and 8.0 and there are no other known water quality problems, then the outdoor furnace may be filled with this water.
4. Water that has a pH level of less than 6.5 or greater than 8.0, or that has other known water quality problems, should not be used to fill the furnace. Instead, water should be supplied from a different source.

Adding Initial Water Treatment

⚠ CAUTION

Avoid damaging your furnace and voiding your warranty. Add water treatment BEFORE adding water to the system. Water treatment in your outdoor furnace is just as important as the oil in a car's engine.

MolyArmor 350 Corrosion Inhibitor (p/n 2900631) gives optimum protection for the furnace water jacket and system parts when it is used to initially treat the water and is maintained at a minimum of 350 ppm of moly and pH level between 8.0 and 9.5. The recommended initial treatment rate for the outdoor furnace is specified by units. One unit of MolyArmor 350 is a 1-gallon (3.78-liter) container.

MOLYARMOR 350 TREATMENT AMOUNTS	
6500 Titanium	3 gallons

1. Add the recommended amount of MolyArmor 350.

NOTE: If the system has a larger than normal water capacity, more MolyArmor 350 should be added at a recommended rate of 6.5 oz. (190 ml) per 10 gallons (37.8 liters) of system water. One unit (1 gallon or 3.78 liters) of MolyArmor 350 will treat 200 gallons (757 liters) of system water.

Filling with Water

NOTE: Other options for filling the system are provided in the Installation Guide.

Connect a garden hose between a domestic water supply and the furnace fill valve (0020-325), which was installed in the cold water return line at a point just prior to its exiting the building. Make sure that valves not being used on the furnace are closed and the valves that are being used are open. Begin filling and inspect for leaks on all fittings. Repair any leaks that are found.

⚠ CAUTION

Feed and return valves that are not being used must be insulated to prevent freezing and breaking.

If furnace is powered, the water level light on the controller can be used to aid with filling. Routinely pay attention to the water level light. If the light is not lit, this indicates that the water level is low and the furnace may need to have water added. Add water until it flows out of the vent pipe.

⚠ CAUTION

Air in the water lines can cause damage to the pump.

Bleeding the System

NOTE: Other options for bleeding air from the system are provided in the Installation Guide.

While filling the outdoor furnace, close the cold water return valve on the furnace for two or three minutes, and then open the valve. This will force trapped air out of the hot water supply line. Repeat this process with the hot water supply valve on the furnace to force air out of the cold water return line. Once both lines have been "bled" continue filling the furnace until the system is full and water comes out of the vent pipe.

Immediately Start the Pump(s); then Heat the System Water to 170°F (76°C)

1. Start the pump(s), refer to Firing the Furnace and start the outdoor furnace. Bring the water temperature up to operating temperature (170°F or 76°C) for two hours with the system circulating. Check the system water level and add water if needed. Note that some water may escape out of the furnace vent tube as the system water is heated.

NOTE: It is important to bring the water in the system up to operating temperature (i.e., 170°F or 76°C) immediately after filling the system. This also applies any time water is added to the system.

NOTE: If there are multiple circuits connected to the outdoor furnace, repeat the process for each circuit.

⚠ CAUTION

The water in the system may be hot. Use caution and the appropriate personal protective equipment (PPE) when checking for leaks.

2. Check the system for leaks. Inspect all fittings and hose ends for any signs of leakage. Use several dry paper towels and wrap them around and squeeze each fitting, valve and pipe connection. The paper towels will get wet even if there is a very small leak. Immediately repair any leaks to eliminate the need for adding water. If a screw-type clamp has been used, it may be possible to stop a very slow leak at a hose clamp by tightening the clamp after the system has warmed up and the poly becomes more pliable. It might also be necessary to install a second hose clamp with the screw positioned on the opposite side.

NOTE: After a week of operating, use the procedure in step 2 to check the system for leaks again.

NOTE: If water is added, it is important to bring the water in the system up to operating temperature (i.e., 170°F or 76°C) immediately. Refer to Water Quality and Maintenance in the Owner's Manual for water testing procedures. If indicated by test results, add MolyArmor 350 as required. Deterioration due to improper operation and/or maintenance is not covered by warranty.

Test the Treated System Water

After circulating the water in the system for at least 24 hours, test the treated system water for the recommended moly (at least 350 ppm) and pH level (between 8.0 and 9.5).

⚠ CAUTION

The water at the drain may be hot. Use caution when obtaining a sample.

1. Obtain a system water sample from the drain at the back of the furnace. Before collecting the sample, open the valve and drain about a quart of water; then carefully fill the sample container without contaminating the sample. **Be sure to properly close the valve when finished.**
2. Dip a test strip from the test kit in the water sample for **1 second** and remove. Shake off excess liquid (very important to prevent water bleed from one pad to the other). Compare moly test pad to the color chart within **10 seconds**. The moly level must be **350 ppm or more**.
3. Compare pH test pad to the color chart at **30 seconds**. The pH of the treated water should be **between 8.0 and 9.5**.

Maintenance Levels

Test the pH and moly levels after the first three months and every six months thereafter, and after adding water to furnace.

NOTE: If using antifreeze, test the pH and Moly levels once each month. If the bacterial issues occur, the pH will decrease.

NOTE: It should not be necessary to add water to the outdoor furnace more frequently than once every twelve months. If it is more frequent, either there is a leak in the system or the outdoor furnace is boiling because of improper operation or maintenance (see Troubleshooting Section in the Owner's Manual). Be sure to locate and repair the problem immediately. Frequently adding water can cause deterioration in the water jacket. Each time water is added, refer to Water Quality and Maintenance in the Owner's Manual for water testing procedures. If indicated by test results, add MolyArmor 350 as required. Deterioration due to improper operation and/or maintenance is not covered by warranty.

Send in Initial Water Sample

Your owner's packet contains a Water Sample Kit for submitting an initial water test. Additional Water Samples Kits are available from your WoodMaster dealer.

Initial Water Sample

You are required to submit an initial water sample within 30 days of purchase of your outdoor furnace.

Deferred Installation

if your outdoor furnace is not being installed within 30 days of purchase, you must email service@woodmaster.com with your name and your furnace serial number. When the furnace installation is complete, send the water sample **within 10 days of the initial fill**.

Check Status of Water Sample

If you have provided an email address, you will receive an email with the results of your water test.

If you did not provide an email address, you will be notified by mail **ONLY** if your water sample test is **NOT ACCEPTABLE**. If your water sample test is acceptable, you will **NOT** be notified with a mailed letter. You can however check the status of your water test online.

Check the status of your water sample at:

WoodMaster.com/w25

You will need your serial number and postal code. Please allow 2-3 weeks for results to be available. For a deferred installation, your status will be available approximately 10 days after you email the deferred installation message.

Annual Water Sample

ANNUAL WATER SAMPLE: You are required to submit a water sample yearly prior to the anniversary date of your initial installation. Record the anniversary date below:

DATE OF INSTALLATION

Water Samples

Maintaining the corrosion inhibitor at a proper level is imperative to preventing corrosion failures. To qualify for the warranty, you must follow the instructions in the Owner's Manual concerning initial water treatment and maintenance. When the outdoor furnace is initially put into service, and once a year after that, you are required to submit a water sample to confirm proper maintenance and water treatment. No warranty claim can be approved unless the outdoor furnace registration and the acceptable levels of water treatment are on file at WoodMaster.

NOTE: It is your responsibility as owner to ensure that your water sample information is accurate and that you submit your samples on a timely basis as required by the warranty for your stainless steel outdoor furnace. Failure to do so will result in a one year warranty.

Water Test Kits and Test Results

DATE	pH LEVEL	MOLY LEVEL

Record the results of pH and Moly level tests in the table above.
If additional space is needed, record on a separate sheet of paper.

It is very important to keep record of water test results (including the date, pH and Moly level). The pH and Moly test strips and indicator have a shelf life of approximately two years that can affect their accuracy. Test kits should be stored in a dry area at room temperature to obtain maximum accuracy over a longer period of time.

Biological contamination can occur if the furnace is not heated up to 170°F immediately after filling it with inhibitor and water as directed.

NOTE: ANY time water is added to the system, it is extremely important to bring the water temperature up to operating temperature (170°F) as soon as possible, even if it is during the off-season. Failure to bring the water in the system up to operating temperature immediately after filling the system can allow bacteria present in the water to multiply and may increase the potential for corrosion in the system.

If the test indicates a significantly lower-than-recommended pH level (below 8.0), add MolyArmor to increase the pH level.

POST HEATING SEASON MAINTENANCE

The water should be left in the outdoor furnace if the outdoor furnace is not being used for an extended period of time.

1. Refer to the Preventive Maintenance Schedule for a list of operations to perform.
2. Shut off the power supply to the outdoor furnace.
3. Place a cover over the chimney to keep rain from entering the outdoor furnace. Clean and oil the chimney flue to the firebox.

Adding Antifreeze to Outdoor Furnace System

If using antifreeze, use ONLY uninhibited, undyed, "raw" PGI (shorthand for Propylene Glycol Industrial grade) with softened water and add the correct amount of MolyArmor 350 to achieve 350 ppm moly and 8.0 to 9.5 pH levels.

Most outdoor furnaces are installed **without** antifreeze when an existing heating system is in place and there is no anticipation of leaving the outdoor furnace unattended for extended periods of time (10 days or more). If the building being heated has an alternate heat source, system water may be kept from freezing by running the circulating pump(s) and drawing heat from the existing furnace or boiler in the home or building.

To prevent freezing if the outdoor furnace is not fired for extended time periods or if lengthy power outages are anticipated during cold weather, a nontoxic propylene glycol may be used in the system. Some types of antifreeze that contain various inhibitors have been known to create problems like coagulation and jelling. To prevent potential problems, **do not use propylene glycol that is premixed with inhibitors.** MolyArmor 350 is compatible with (raw) propylene glycol. It is important to use MolyArmor 350 with straight propylene glycol for corrosion protection. If adding antifreeze to the system, it is imperative that the entire system contain **at least 30% antifreeze concentration mixed with water that is 6.5 to 8.0 pH. Softened water is recommended, if available. Do not use reverse osmosis or deionized water** that has very low pH. Bacterial growth is likely to occur with low antifreeze concentrations and can cause corrosion in the furnace water jacket and/or clogging of heat exchangers. To confirm the antifreeze solution is adequate and to kill bacteria, immediately heat the system up to 170° F, allow the pumps to circulate for at least 24 hours and then obtain a sample of the system water. Using an antifreeze tester, the solution must be protected to 10° F (-12° C) or below.

NOTE: If using antifreeze, test the pH and Moly levels once each month. If the bacterial issues occur, the pH will decrease.

NOTE: Be sure to adhere to all warnings and precautions on the antifreeze label.

NOTE: Do not use automotive or RV types of antifreeze.

Wood Selection and Preparation

For the best results, it is best to burn seasoned split wood. However, it may be possible to burn some unsplit wood with the split wood depending on quality, size, moisture content and wood type. Properly seasoned wood has a moisture content of 20% or less. It is darker, has cracks in the end grain, and sounds hollow when smacked against another piece of wood. Most wood needs to be split to dry down to 20% within a year. Wood between 4" and 8" (10 and 20 cm) in diameter works well in most cases. Pieces of wood that are too large can reduce output capacity because they burn slower.

- Wood that works well in most cases:
 - Is between 4" and 8" (10 and 20 cm) in diameter
 - Is approximately 60-70% of the length of the firebox
 - Typically weighs 10-15 pounds per cubic foot for heavy heat loads
- Pieces of wood that are too large can reduce output capacity because they burn slower.
- Seasoned wood burns more efficiently, minimizes the amount of creosote formation and reduces emissions.
- Maintain a quantity of smaller, drier pieces of wood for relighting the fire if the wood load is burned very low or becomes completely empty.
- Green wood contains about 50% moisture by weight. Energy is required to heat the wood and evaporate the moisture - energy which could have been used to provide heat for the building. The illustration below shows that burning drier, seasoned wood provides more energy for heating your building(s) compared with burning green, unseasoned wood that uses more energy to evaporate the moisture and provides less energy for heating.

NOTE: Do not store wood within the outdoor furnace installation clearances or within the spaces required for fueling, ash removal and other routine maintenance operations.

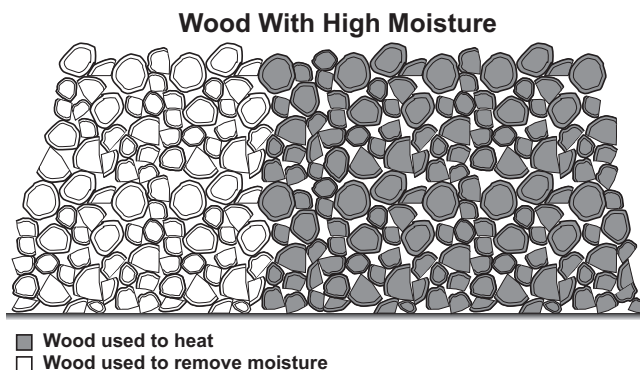
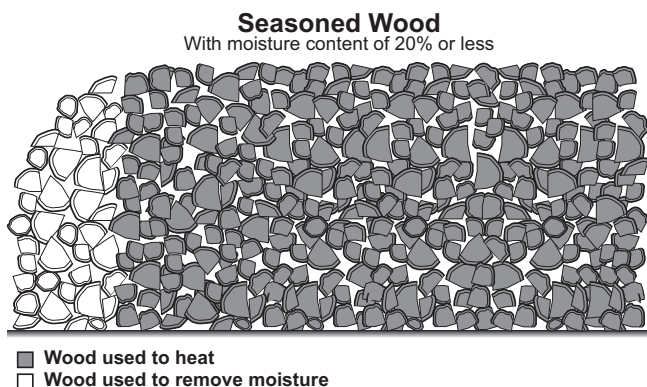

Before You Start Operating Your WoodMaster Outdoor Wood Furnace

Be sure to read carefully and observe all of the information in the entire Owner's Manual.

If any questions arise that cannot be answered by the information in this manual, be sure to contact your dealer.

Operating Instructions

Firing the Furnace

Paper and kindling should be used for starting the fire. Build a small fire, then add wood as needed. Be sure that the pumps are circulating when firing the furnace. Once the furnace has reached 170 degrees, the furnace is ready to be filled to capacity to operate for a 12-hour period. Load wood towards the back of the furnace for improved efficiency. WoodMaster recommends burning cut, split and seasoned wood. Do not overfill so that hot coals fall out of the furnace when opening the fuel door. During periods of warmer weather, you may find it to have creosote inside the firebox. It is important to fill the furnace only with enough wood to last a 12- to 24-hour period. After burning your furnace for a period of time, you will discover how much wood is needed per day and what types of wood burn the best.

⚠ CAUTION

Do not fire with garbage, rubber, gasoline or any oil products. Do not use chemicals or any oil products that were listed above to start fires.

Loading the Furnace

Before opening the firebox door, pull the bypass baffle rod out to the first stop point to vent the furnace. Use caution when opening the fuel door since fire and high temperatures may be present. When loading your furnace, it is recommended that you stack your wood lengthwise in two rows as shown below. This will allow air from the draft fan to circulate properly creating the optimum burn environment.

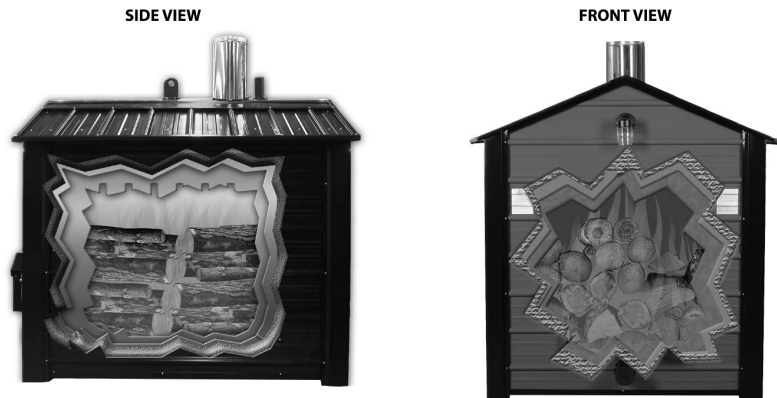

⚠ WARNING

Keep your face away and stay as far away as possible from the firebox door area when opening the door.

Load the back of the furnace first, stacking the wood lengthwise in the fire box. After the rear is loaded, fill the front of the furnace in the same fashion. Be mindful of the latch on the door when you are stacking the wood in the front.

⚠ WARNING

Use extreme care if adding wood when wood or coals are already present. Very hot gases may be coming out of the firebox door opening.

Maintenance

PREVENTIVE MAINTENANCE SCHEDULE

Regular maintenance and inspections can help extend the life of your outdoor furnace and prevent high-cost repairs. This table is meant to serve as a general guideline until you become acquainted with how the outdoor furnace operates with your specific application.

OPERATION	SERVICE INTERVAL						See Section Number
	Before first operation of season	Daily	Weekly	Monthly	Semi-Annually	Post-Season	
Check water level.	●	●				●	C
Remove ash.			A				M-2
Completely remove ash.					●	●	M-2
Inspect chimney, door, vent seals.			●			●	M-5
Inspect chimney and chimney connector for creosote.	●		A			●	M-4
Clean out Baffle Bypass.	●		A			●	M-3
Stir ash and pull hot coals to front of firebox.		●					M-1
Scrape bottom of firebox.				●		●	M-1
Check pH and moly levels of water.	●				B	●	C

NOTE: Check daily for build-up of creosote until experience shows how often cleaning is necessary.

- A** Weekly until interval for your application can be determined.
- B** When new, after three months, then every six months thereafter.
- C** Refer to **Water Quality and Maintenance**

ROUTINE MAINTENANCE

⚠ CAUTION

Use only genuine WoodMaster Parts and Accessories if it ever becomes necessary to replace any component of the outdoor furnace.

Routine inspections and maintenance are essential to the proper operation and longevity of the outdoor furnace. The items indicated in the preventive maintenance schedule are intended to serve as a guideline. Actual intervals between inspections and maintenance may vary depending on a number of factors, including your heat load requirements, type of wood used, and outdoor temperatures.

NOTE: Proper firebox maintenance is essential to the longevity of the outdoor furnace.

⚠ CAUTION

Do not burn plastic, garbage, treated wood or fuels not listed for this outdoor furnace.

NOTE: Chloride or sulfurous gases can be generated if plastic or rubber is burned and will mix with the moisture from the wood to form hydrochloric or sulfuric acids in the firebox, creating corrosion.

MAINTENANCE SECTIONS

M-1. Ash Rotation

Maintaining proper ash rotation is crucial to the performance of your WoodMaster furnace. Keeping a fresh bed of coals on the top of your ashes will ensure that you get the most out of whatever kind of wood that you burn by burning and breaking down the wood to its smallest usable form. To make sure that you are rotating your ashes properly, use the following procedure.

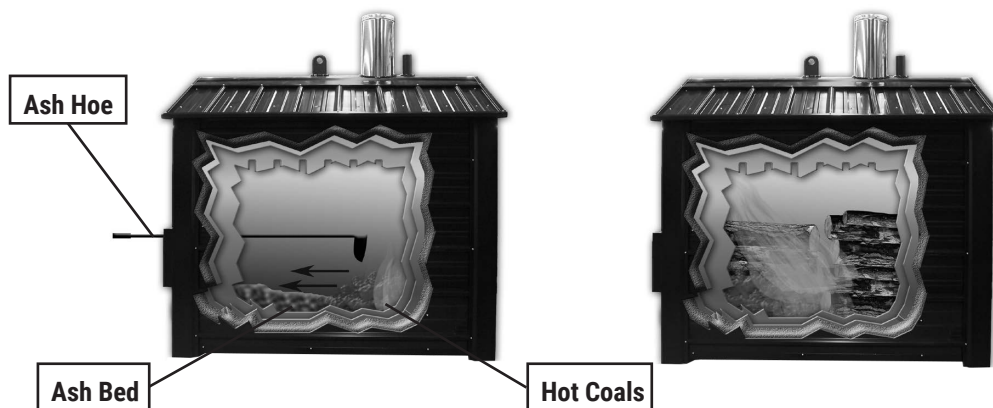

1. With your Ash Hoe, pull the hot coals from the back of the furnace to the front.
2. Load the back of the furnace first, stacking the wood as shown in the previous section. Then fill the front of the furnace.
3. When needed, scrape the bottom of the firebox to remove any deposits or ash buildup.

By loading the furnace as explained, the flame will be towards the front of the furnace and work its way back. This will cause your wood to burn more thoroughly.

M-2. Ash Removal and Disposal (Weekly or As Needed)

⚠ CAUTION

Always wear the appropriate personal protective gear when cleaning ashes from the firebox.

Remove the ashes when the furnace is very low on wood. If your WoodMaster furnace is not equipped with an Ash Auger System, use a shovel to take the ashes from the front of the firebox and use a rake to pull the ashes from the rear of the furnace to create a level bed of hot coals. The ashes should be placed in a metal container with a tight fitting lid. The closed container of ashes should be placed on a noncombustible floor or on the ground and well away from all combustible materials, pending final disposal. Ashes should be retained in the closed container until all of the cinders have thoroughly cooled.

⚠ CAUTION

Hot coals can last for days; disposing of them improperly or too soon can cause a fire.

⚠ WARNING

When cleaning the outdoor furnace, be careful not to spill any hot ash outside of the noncombustible container.

M-3. Baffle Bypass Ash Removal (Weekly or As Needed)

To ensure that your Baffle Bypass remains clear of any excessive build-up, you will need to clean it out. To effectively clean out the Baffle Bypass you must:

1. Pull the rod back until it hits the stop.
2. Twist the rod clockwise and pull back in order to pass over the stop.
3. Slide rod in and out several times to clean the Baffle Bypass.
4. Slide the rod all the way in.

M-4. Creosote - Formation and Need for Removal

When wood is burned slowly, it produces tar and other organic vapors, which combine with expelled moisture to form creosote. The creosote vapors condense in the relatively cool chimney flue of a slow-burning fire. As a result, creosote residue accumulates on the flue lining. When ignited, this creosote makes an extremely hot fire. The chimney connector and chimney should be inspected at least twice monthly during the heating season to determine if a creosote buildup has occurred. If creosote has accumulated it should be removed to reduce the risk of a chimney fire.

M-5. Chimney, Chimney Cap and Seals

Inspect all silicone caulking and make sure it has a good seal between the chimney and the roof so moisture can't enter furnace. Also inspect silicone seal for the vent pipe and hanger strap. If you have an ash auger, remove it, clean out all ashes and scrape excess creosote from the fire chamber surface. Reinstall the ash auger. Moisture combined with ashes will eat through metal in a very short time.

⚠ CAUTION

Corrosion in the firebox is not a workmanship defect. Warranty does not cover firebox corrosion! Neglecting to clean your furnace or cover the chimney when not in use, will void your warranty. When the furnace is in use, be sure that you maintain a good ash rotation. This should be done weekly.

If you are using a spark arrester or a chimney cap, you will need to provide your furnace with a little more maintenance. It is very important that you keep these areas free of any creosote build up at all times. Failure to do this will cause harm to the roof of your furnace.

⚠ CAUTION

Use of a spark arrester or chimney cap will require extra care and maintenance. If you don't maintain it properly, it may cause damage to your roof.

M-6. Post Heating Season Maintenance

The water should be left in the outdoor furnace if the outdoor furnace is not being used for an extended period of time. Protect your fire chamber by placing the chimney cap over the chimney during the off-season.

1. Refer to the Preventive Maintenance Schedule for a list of operations to perform.
2. Shut off the power supply to the outdoor furnace.
3. Place a cover over the chimney to keep rain from entering the outdoor furnace. Clean and oil the chimney flue to the firebox.

TROUBLESHOOTING

A. BUILDING IS LOSING TEMPERATURE

1. **Out of wood** - Check firebox to see if fire is out. Add wood as necessary. Use good quality wood since poor quality wood will have very short burn times.
2. **Circulation valve(s) closed** - Be sure all valves in the system are open.
3. **Circuit breaker off** - Check the circuit breaker that supplies power to the outdoor furnace.
4. **Circulation pump(s) not operating** - Check that circulation pumps are operating. If not, disconnect power to the pump. Close valves at the pump. Disassemble the pump and try to turn the pump shaft. If the shaft is stuck, replace the pump cartridge. Replace only the cartridge whenever possible. If necessary, replace the pump. Follow instructions supplied with the pump.
5. **Air in system** - Check for air in the water lines or heat exchangers. If you hear a gurgling sound in a heat exchanger, air is present in the system. Shut off the pump, wait 15 seconds and start the pump. If it is necessary to force air from lines, refer to Initial Start-up Procedures.
6. **Outdoor furnace exhaust obstructed** - Check furnace exhaust for obstructions by observing the amount of smoke coming out of the chimney with the firebox door slightly ajar. If smoke seems very restricted, remove the firewood and hot coals; then check the chimney (top and bottom) and behind the baffle for obstructions.
7. **Building(s) poorly insulated or uninsulated** - Poorly insulated or uninsulated buildings, buildings with uninsulated or poorly insulated ceilings, or a lack of proper insulation under radiant flooring can cause excessive fuel consumption and/or heating problems.
8. **Supply and return lines installed incorrectly** - Make sure the hot supply water line is connected to the correct fitting on the outdoor furnace and heat exchanger.
9. **Circulation pump(s) installed backwards** - Check that pump flow direction is correct. If not, shut off power to pump. If the flow is not in the correct direction, disconnect pump from water line and reverse pump mounting to correct flow direction. If the pump is not mounted on the outdoor furnace, check for proper pump mounting location.
10. **Underground supply and return lines insulated poorly** - Heat loss from poorly insulated underground supply and return lines is often indicated by an unusually high amount of snow melting above the lines when the ground temperature is 10°F or colder.
11. **Supply and return lines uninsulated** - Uninsulated supply and return lines in areas that are not intended to be heated (unheated crawl spaces, etc.) may cause excessive heat loss. Insulate the supply and return lines.

12. **Poor water quality** - Water with high amounts of solids, sand or dirt can create deposits inside the wall of heat exchanger components, reducing the amount of heat output. If this condition is suspected, contact your WoodMaster dealer.
13. **Check Fan Draft and Draft Flapper** - Make sure they are operating properly.
14. **Check Fan Switch on ETC to be sure it is ON** - Fan Switch should only be off while filling or cleaning.
15. **If water temperature is reading 120°F or lower** - push Set Button on ETC System to restart Heating Mode.

B. OUTDOOR FURNACE IS OVERHEATING

1. **Air entering through the door** - Make sure the firebox door is properly latched and check the condition of the door rope. This is the fire-resistant gasket around the firebox door. Make sure the door has a tight seal.
2. **Check air intake on firebox door** - Make sure cover closes tight.

NOTE: If the water in the outdoor furnace boils, air can enter the lines and could damage the pump. Be sure to remove air from system (see Filling with Water section). A hissing sound coming from a pump, in most cases, means there is air in the system. Check water level to ensure that your furnace is full.

3. **Water is not circulating** - The pump should run continuously and water needs to circulate continuously through the supply and return lines to keep water temperature uniform in the outdoor furnace.
4. **Circulation valve(s) closed** - Be sure the proper valves in the system are open to allow circulation.
5. **In extremely warm weather** - a smaller amount of wood should be used.
6. **Check auger head for air leaks** and that the ash auger head discharge door is closed.

D. FREQUENT PUMP TROUBLE OR POOR WATER CIRCULATION

1. **Pump mounted incorrectly** - Pump must be mounted on the back of the furnace. See Mounting the Pump section.
2. **Deposits in water lines/heat exchanger walls** - If water high in silica or other mineral content has been used, material deposits may build up on the insides of the supply and return lines and on the heat exchanger walls. If this occurs, the system will need to be drained and then cleaned using Sludge Conditioner (p/n 166). The system must then be refilled with the proper amount of corrosion inhibitor and fresh water.
3. **Water will not circulate** - If the system has been drained and refilled, or if the system has been opened for any reason (e.g., replacement of pump, adding heat exchangers, repairing a leak), the system must be purged (see Initial Start-up Procedures).

4. **Poor water quality** - Water with high amounts of solids, sand or dirt can cause frequent pump failure. Use softened and/or filtered water.

E. ERRATIC TEMPERATURE READING ON GAUGE

1. **Return water too cold** - Water circulation may be too slow. The return water should be no more than 20°F-25°F less than the hot supply water. If the water returning to the outdoor furnace is too cold, it may cause erratic temperature readings. Check for partial air lock or install larger pump.

F. BURNING AN EXCESSIVE AMOUNT OF WOOD

1. **High volume water heating** - High volume water heating (e.g., car wash, swimming pool, etc.) will require high wood consumption.
2. **Excessive heat loss** - See Building is Losing Temperature section.
3. **Air entering through door** - See item 1 of Outdoor Furnace is Overheating.
4. **Excessive draft** - If a very tall extension is added to the chimney, the increased draw through the draft may cause excessive wood consumption. Decreasing the draft opening may increase efficiency and reduce wood consumption.
5. **Supply and return line heat loss** - If supply and return lines are buried in a wet, low-lying area, there may be a large heat loss which would greatly increase wood consumption.
5. **High heat demand** - Concrete slabs (with radiant heat) that are poorly insulated or are exposed to water or cold outside temperatures will require increased wood consumption (see Hydronic Installations section). Bringing a concrete slab up to temperature the first time will take a considerable amount of time and wood; once warm, wood consumption will be reduced if the concrete slab and building are insulated properly. The following will also have a high heat demand: poorly insulated buildings, buildings with large amounts of glass windows/doors, buildings with overhead doors, greenhouses, uninsulated crawl spaces, outdoor air infiltration and air leaking through foundation.

Electronic Temperature Control (ETC) Guide

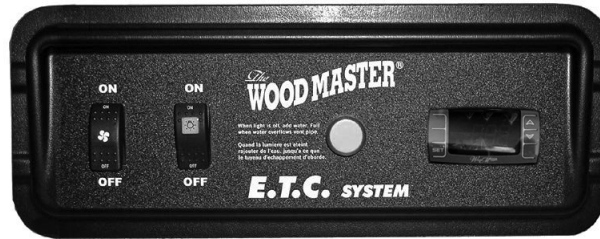

Function:

- The ETC monitors and controls the WoodMaster water temperature by controlling the draft and draft fan.
- During normal operation (adequate wood supply) the controller will turn off the draft and draft fan when the water reaches 170°F (Set) and will turn on the draft and draft fan when the water falls 10°F (Hy).
- During shut down (low wood supply) or when the water falls to 120°F (ALL) the controller will shut off the draft and draft fan. At this time, the WoodMaster will need to be filled with wood and the ETC will need to be reset (see Startup).

Energy Start Shut-Down:

- This function shuts down the WoodMaster draft and draft fan when not in use and back-up system is operating (example: if gone for the weekend, wood firing furnace runs out of wood and back-up system takes over). To restart the WoodMaster, simply push the Set Button.

Start Up / Reset:

- The first time the WoodMaster is powered up or when it has shutdown, the controller display will flash "LA (Low Alarm) two times and then display the water temperature for two seconds and then start over. This is normal and indicates the system has shut down because the water is at or below 120°F.
- To start up (or reset) your WoodMaster, press the set button one time. The display will indicate "rSt" (reset) and after 1 to 2 seconds, the draft will open and the draft fan will turn on. The display will continue to flash "LA" and the water temperature will be displayed until the water temperature reaches 140° (ALL + 20). After water temperature reaches 140°F, only the water temperature will be displayed until the water temperature falls to 120°F.
- **Note:** The fan switch must be in the on position.
- **Note:** Fan switch can be shut off when loading or for servicing.

Parameter Description and Factory Settings:

- Set (set point) - 170°F
- Hy (Differential) - 10°F
- ALL (Low Alarm) - 120°F

How To:

- **View Set Point** — Push and immediately release the set key, display will indicate set point and will return to water temperature after 5 seconds.
- **Change the Set Point** — Push and hold the set key until the set point is displayed, change the value using the up and down arrows, and press the set key. The set point will flash a few times and then the display will return to water temperature.
- **Change Hy or ALL** — Push and hold the set and down arrow keys at the same time until HY is displayed. Using the up and down arrows, select the parameter to be changed (Hy or ALL), push the set key once (value of parameter should be displayed), use arrows to change value, and push the set key (value should flash a few times). After 10-15 seconds the display will change back to water temperature.

Green Float Light:

- **Green light ON:** Water level OK.
- **Green light OFF:** Water level low, add water through vent pipe or follow fill valve instructions if system is installed with an indoor fill valve.

Light Switch:

- Operates light.

Fan Switch:

- The fan switch must be on during normal operation, but may be turned off to fill furnace or for maintenance.

ETC Reference**1. GENERAL WARNING****1.1 PLEASE READ BEFORE USING THIS MANUAL**

- This manual is part of the product and should be kept near the instrument for easy and quick reference.
- The instrument shall not be used for purposes different from those described hereunder. It cannot be used as a safety device.
- Check the application limits before proceeding.

1.2 SAFETY PRECAUTIONS

- Check the supply voltage is correct before connecting the instrument.
- Do not expose to water or moisture; use the controller only within the operating limits avoiding sudden temperature changes with high atmospheric humidity to prevent formation of condensation.
- Warning: disconnect all electrical connections before any kind of maintenance.
- The instrument must not be opened.
- In case of failure or faulty operation contact your WoodMaster dealer with a detailed description of the fault.
- Ensure that the wires for probes, loads and the power supply are separated and far enough from each other, without crossing or intertwining.

2. GENERAL DESCRIPTION

The ETC is designed to control the furnace temperatures between the parameters that are selected by the operator.

3. CONTROLLING LOADS

3.1 THE REGULATION OUTPUT

The regulation is performed according to the temperature measured by the probe.

When the appropriate temperature, SP or HY, is reached the ETC will respond and control the combustion solenoid(s) and fan(s) accordingly.

The Hy value is automatically set under the Set Point. If the temperature decreases and reaches set point minus differential the regulation output is activated and then turned off when the temperature reaches the set point value again.

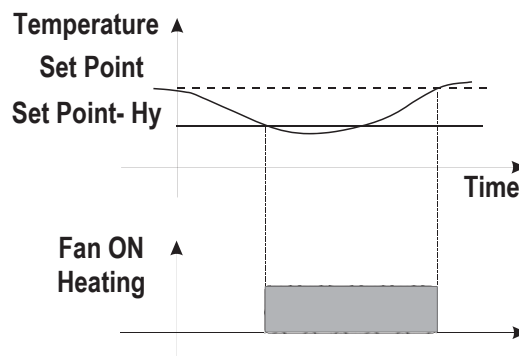

4. FRONT PANEL COMMANDS

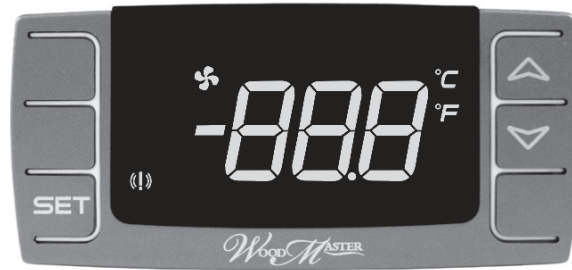

SET: Displays the target set point; selects and confirms a parameter in the programming mode. Also used in conjunction with (UP) and (DOWN) to view the Min and Max recorded temperatures and to reset the stored temperatures.

(UP): To see the last temperature alarm that occurred; in programming mode it browses the parameter codes or increases the displayed value.

(DOWN): To see the last temperature alarm that occurred; in programming mode it browses the parameter codes or decreases the displayed value.

KEY COMBINATIONS:

(UP) + (DOWN) - To lock & unlock the keyboard.

SET + (DOWN) - To enter in programming mode.

SET + (UP) - To return to the temperature display.

4.1 USE OF LEDS

Each LED function is described in the following table.

LED	MODE	FUNCTION
🌀	ON	Output enabled
🌀	Flashing	Anti-short cycle delay enabled
°F	Flashing	Programming Phase
(!)	ON	Temperature Alarm has happened. Stays on until reset

5. TEMPERATURE ALARM AND ITS DURATION

Example of Low temperature alarm

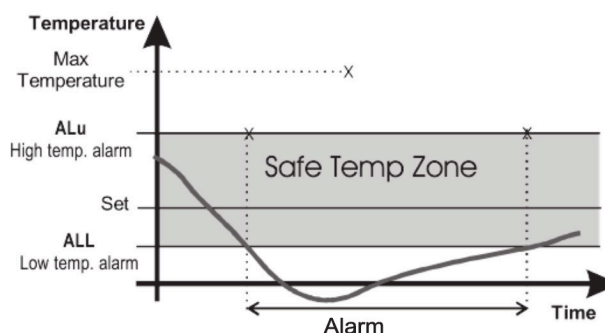

5.1 HOW TO SEE THE ALARM DURATION AND MAX (MIN) TEMPERATURE

If the alarm LED is on, an alarm has taken place.

To see the kind of alarm, the max (min) reached temperature and alarm duration do as follows:

1. Push the UP or DOWN key.
2. On the display the following message is shown:
"HAL" for high temperature alarm ("LAL" for the minimum alarm), followed by the Maximum (minimum) temperature. Then the "tiM" (tiMe) message is displayed, followed by the "Duration" in h.mm.
3. Then the instrument displays the temperature once again.

NOTE1: if an alarm is still occurring the "tim" shows the partial duration.

NOTE2: the alarm is recorded when the temperature comes back to normal values.

5.2 HOW TO RESET A RECORDED ALARM OR ONE THAT IS STILL OCCURRING

1. Hold the SET key pressed for more than 3s, while the recorded alarm is displayed (the rSt message will be displayed).
2. To confirm the operation, the "rSt" message starts blinking and the normal temperature will be displayed.

6. MAIN FUNCTIONS

6.1 HOW TO SEE THE SETPOINT

Push and immediately release the SET key - the display will show the Set point value; Push and immediately release the SET key or wait for 5 seconds to display the probe value again.

6.2 HOW TO CHANGE THE SETPOINT

1. Push the SET key for more than 2 seconds to change the Set point value.
2. The value of the set point will be displayed and the °F starts blinking.
3. To change the Set value push the UP or DOWN arrows within 10s.
4. To memorize the new set point value push the SET key again or wait 10s.

6.3 HOW TO CHANGE A PARAMETER VALUE

To change the parameter's value operate as follows:

1. Enter the Programming mode by pressing SET and DOWN keys for three seconds (the °F LED starts blinking).
2. Select the required parameter. Press the SET key to display its value.
3. Use UP or DOWN to change its value.
4. Press SET to store the new value and move to the following parameter.

To exit: Press SET + UP or wait 15s without pressing a key.

NOTE: the set value is stored even when the procedure is exited by waiting for the time-out to expire.

6.4 HOW TO LOCK THE KEYBOARD

1. Keep pressed for more than 3s the UP and DOWN keys.
2. The "POF" message will be displayed and the keyboard will be locked. At this point it will be possible only to see the set point or the MAX (and) MIN temperature stored.
3. If a key is pressed more than 3s the "POF" message will be displayed.

6.5 TO UNLOCK THE KEYBOARD

Keep pressed together for more than 3s the UP and DOWN keys, until the "Pon" message will be displayed.

7. PARAMETERS

REGULATION

Hy Differential: (1 ÷ 255 °F) Intervention differential for set point. Fan Cut IN is Set Point Minus Differential (Hy). Fan Cut OUT is when the temperature reaches the set point.

DISPLAY

CF Temperature measurement unit:

To change from °F to °C, contact your WoodMaster dealer.

ALARM

ALL Minimum temperature alarm: (120°F) when this temperature is reached the alarm is enabled and fan will shut off.

AFH Differential for alarm recovery: (1°F ÷ 45°F) It sets the value above the alarm value for alarm recovery.

8. ALARM SIGNALS

Message	Cause	Outputs
"LA"	Minimum temperature alarm	Outputs unchanged

8.1 ALARM RECOVERY

Probe alarm "P1" starts some seconds after the fault in the related probe; it automatically stops some seconds after the probe restarts normal operation. Check connections before replacing the probe.

Temperature alarms "DA" and "LA" automatically stop as soon as the thermostat temperature returns to normal values.

9. DEFAULT SETTING VALUES

Label	Name	Range	°F	Level
Set	Set point	LS ÷ US	170	Pr1
Hy	Differential	1 ÷ 255°F	10	Pr1
ALL	Minimum temperature alarm	120°F	120	Pr1

Fig. 1

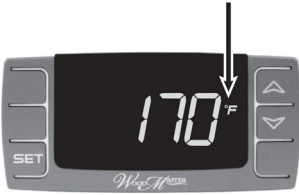

Fig. 2



Fig. 3



Fig. 4



Fig. 5



Fig. 6



Changing ETC Settings

NOTE: The procedures are the same whether you are using degrees (F) or degrees (C).

Changing the Set Point

1. Press and hold the set button for 3 seconds or until the °F is flashing. The number that appears is the Set Point (Fig. 1).
2. Use the up or down arrow buttons to adjust the setting.
3. Press the set button to lock in the settings.

Changing the Hy

1. Press and hold the down arrow and set buttons until the display reads Hy (Fig. 2).
2. Release the arrow down and set buttons.
3. Press set button, the number displayed is the differential (Fig. 3).
4. Press the arrow up or down button to adjust (Fig. 4).
5. Press the set button (Fig. 5).
6. The display will read ALL for approximately 30 seconds, (Fig. 5) it will then return to the water temperature reading (Fig. 6).

Changing the All

1. When the ETC reads ALL from the previous step, press the set button. The number that appears is the Low Alarm temperature.
2. To adjust the number press the up or down arrow.
3. Press the Set button to lock in the setting.

Definitions

Set Point - The temperature at which the fan will shut down, until hysteresis is achieved.

Hy, aka Differential - The amount, in degrees, the temperature has to drop in order to start the fan.

ALL, aka Low Alarm - The temperature at which the furnace will shut down. At which point the furnace should be reloaded and the control is reset.

NOTE: The temperature scale can be changed from Fahrenheit to Celsius with the hot key from your WoodMaster Dealer.

CAUTION: Do not set your (SP) lower than your (ALL)!

WoodMaster Digital Aquastat Factory Settings		
Set Point (SP)	170°F	76.7°C
Differential (HY)	10°F	5.5°C
Low Alarm (ALL)	120°F	48.9°C

WoodMaster Digital Aquastat Minimum and Maximum Factory Settings	
Set Point (SP)	100°F to 180°F 38°C to 82°C
Differential (HY)	1°F to 45°F 1°C to 25°C
Low Alarm (ALL)	-67°F to 302°F -55°C to 150°C

WIRING DIAGRAMS

AQUASTAT HARNESS

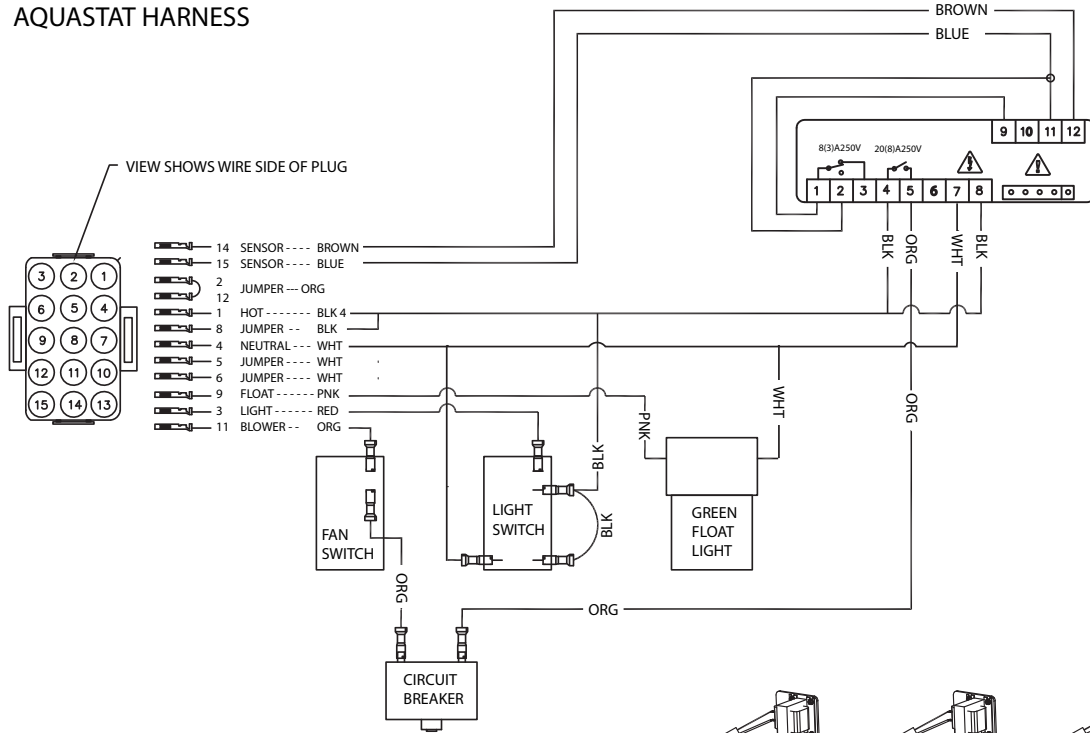

6500 STOVE HARNESS

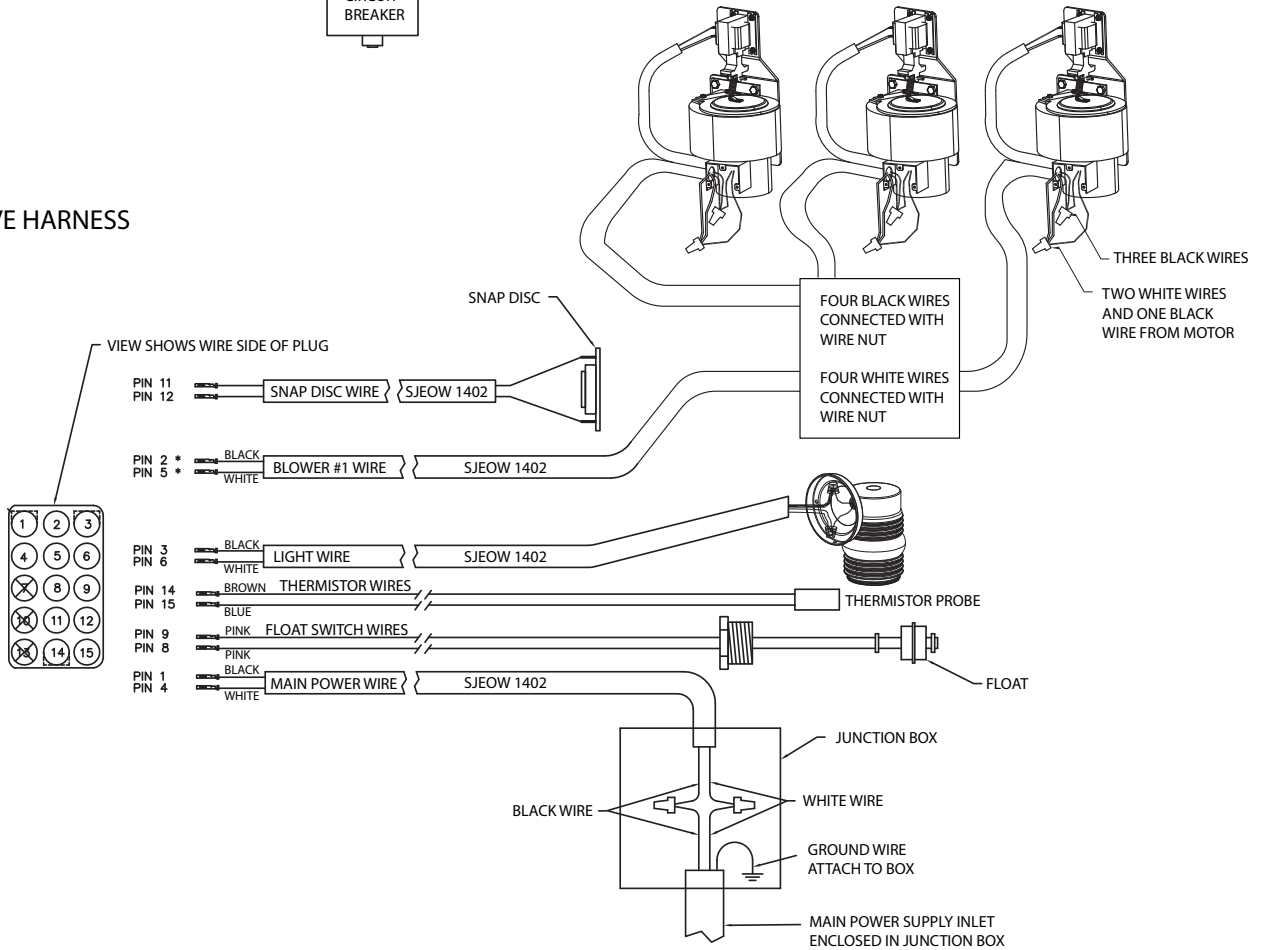

Technical Specifications

Specification	6500
Water Capacity (gal.)	420
Amp Draw* @ 120V AC, 60 Hz	Max. - 19.8 A Idle - 0.5 A Avg. Running - 6.41 A
Heating Capacity**	20,000 sq ft
Firebox Dimensions	60" x 58"
Weight (filled with water)	6,927 lbs
Loading Door Opening Outside Dimensions	44" x 31"

*Amp draw may vary depending on the revision of your furnace and external devices attached to your furnace. Maximum Amp Draw can only occur when all devices are operating; this only happens momentarily at the start-up.

**Actual results will vary depending on the system, applications and insulation values.

WARRANTY COVERAGE

The warranty obligations of WoodMaster, Inc. ("WoodMaster") are strictly limited to the terms, conditions, limitations and exclusions set for in these warranties:

Limited One-Year Warranty - WoodMaster, Inc. ("WoodMaster") warrants to the original Owner, WoodMaster CleanFire, FireMax and Traditional Titanium Series outdoor furnaces against defects in workmanship for a period of ONE (1) YEAR from the date of original retail purchase provided that the Owner strictly complies with instructions in the Owner's Manual. The controller is covered for workmanship defect failures for two (2) years from the furnace purchase date.

If failure of a warranty-covered part occurs that is caused by a defect in workmanship, WoodMaster will, at its option:

1. repair or replace (using new or refurbished replacement parts) the defective or failed part; or
2. exchange the furnace with a comparable model furnace that is new or manufactured from new or serviceable used parts and is at least functionally equivalent to the original furnace.

Optional Limited 25-Year Extended Warranty - WoodMaster provides the original Owner with an Optional Limited Twenty-five (25) Year Extended Warranty from the original retail purchase date of the furnace provided that all qualifying requirements are met.

Optional Limited 25-year Extended Warranty coverage:

If a failure of the welded firebox/water jacket occurs that is caused by a defect in workmanship or corrosion, WoodMaster shall, at its sole discretion, elect one of the following remedies:

1. Repair or replace (using new or refurbished replacement parts) the defective or failed portion of the welded firebox/water jacket based on the date of original retail purchase, according to the following prorated scale:
 - Years 1-5: Parts and labor covered at 100%
 - Year 6: Parts covered at 70%
 - Year 7: Parts covered at 60%
 - Year 8: Parts covered at 50%
 - Year 9: Parts covered at 40%
 - Years 10-20: Parts covered at 15%
 - Years 21-25: Parts covered at 10%
2. Exchange the furnace with a comparable model furnace that is new or manufactured from new or serviceable used parts and is at least functionally equivalent to the original furnace; or
3. Provide a discount off of the retail purchase price of a new WoodMaster furnace of comparable model based on the pro-rated scale: Years 1-5: 100%; Years 6-7: 50%; Years 8-10: 40%; Years 11-15: 30%; Years 16-25: 10%.

Any replacement furnace or part provided under this warranty assumes the remaining warranty of the original furnace or part for ninety (90) days from the date of replacement or repair, whichever period provides longer coverage. As a condition of any replacement or remedy under this limited warranty, WoodMaster may, at its sole discretion, require the return of the replaced furnace or part to WoodMaster for inspection, recycling, or disposal. Wear parts, electrical parts, and other parts that are not welded to the firebox/water jacket are excluded from this extended warranty.

Optional Limited 25-year Extended Warranty qualifying requirements:

1. The Limited Warranty Registration Form must be fully completed and sent to WoodMaster within seven (7) days of the original Owner taking possession of the furnace otherwise this Optional Limited 25-year Extended Warranty will not be in effect.
2. The Owner must strictly comply with the instructions set forth in the Owner's Manual; otherwise, this Optional Limited 25-year Extended Warranty will not be in effect. Without limitation, the Owner must maintain Manufacturer-Approved Corrosion Inhibitor at the proper concentration, as it is imperative to preventing corrosion and is an essential condition of coverage. In addition, the Owner must submit a Furnace water sample to WoodMaster when the Furnace is initially placed into service and annually thereafter to verify compliance with maintenance and corrosion inhibitor requirements. This extended warranty will not be in effect, and no warranty claim can be approved unless all required water test verifications are on file at WoodMaster. In the absence of valid water test results on file with WoodMaster demonstrating continuous compliance with required corrosion inhibitor levels, it shall be conclusively presumed that the corrosion inhibitor levels were not properly maintained, and all warranty coverage for corrosion, defects, failures, or damage of any kind shall be denied.

EXCLUSIONS AND LIMITATIONS - These Limited Warranties apply only to WoodMaster CleanFire, FireMax and Traditional Titanium Series outdoor furnaces. These limited warranties cover only those defects or corrosion failures that arise as a result of normal use of the outdoor furnace and does not cover any other defects or problems, including those resulting from: (a) improper maintenance; (b) operation outside the furnace's specifications (see owner's manual), accident, abuse, misuse, misapplication, or parts that are not factory-installed; (c) service performed by anyone other than WoodMaster, unless authorized by WoodMaster in writing; (d) modifications undertaken without the written permission of WoodMaster; or (e) if any WoodMaster serial number has been removed or defaced.

The optional limited extended warranty shall be void if the Owner fails to maintain the proper amount of Manufacturer-Approved Corrosion Inhibitor in the system, fails to submit water samples to WoodMaster as required, or burns materials in the firebox other than the recommended fuels listed in the Owner's Manual.

This standard One-year Limited Warranty and the Optional Limited 25-year Extended Warranty exclude the cost of shipping, labor required to remove or reinstall the furnace, plumbing labor and/or parts and the cost of alternative heat if the furnace is out of service for repairs. Both warranties exclude replacement of water, corrosion inhibitors or other additives, and parts used in the system whether or not mounted on the furnace including without limitation, pumps, valves, and piping.

WoodMaster is not liable for damage or repairs required as a consequence of faulty installations or applications by others or any event of *force majeure*. WoodMaster further shall not be liable for incidents or accidents which can be prevented by the Owner or that occur from the operation of the outdoor furnace. A backup heating system should be in place to prevent damage in case of failure to refuel the outdoor furnace or in the event that mechanical failure of the outdoor furnace or system occurs. Heat replacement representations found in WoodMaster promotional information should be used only as a guideline. Heat loss for all applications with all weather extremes and other heat variables must be considered when sizing an outdoor furnace for different applications.

THESE LIMITED WARRANTIES AND REMEDIES SET FORTH ABOVE ARE EXCLUSIVE AND IN LIEU OF ALL OTHER WARRANTIES, REMEDIES AND CONDITIONS, WHETHER ORAL OR WRITTEN, EXPRESS OR IMPLIED. WOODMASTER SPECIFICALLY DISCLAIMS ALL IMPLIED WARRANTIES, INCLUDING, WITHOUT LIMITATION, WARRANTIES OF MERCHANTABILITY AND FITNESS FOR A PARTICULAR PURPOSE. TO THE EXTENT IMPLIED WARRANTIES CANNOT BE LAWFULLY DISCLAIMED, SUCH WARRANTIES SHALL BE LIMITED IN DURATION TO THE DURATION OF THESE LIMITED WARRANTIES.

No WoodMaster dealer or employee is authorized to modify, extend, or add to these limited warranties. WOODMASTER IS NOT RESPONSIBLE FOR DIRECT, SPECIAL, INCIDENTAL OR CONSEQUENTIAL DAMAGES RESULTING FROM ANY BREACH OF WARRANTY OR CONDITION, OR UNDER ANY OTHER LEGAL THEORY. Some states or provinces do not allow limitations on the duration of implied warranties or conditions, or the exclusion or limitations of incidental or consequential damages; therefore, the above limitations or exclusions may not apply to you. These warranties provide specific legal rights, and you may have other rights that vary by state or province.

OBTAINING WARRANTY SERVICE - To obtain warranty service, contact the WoodMaster dealer from whom you purchased your furnace or contact WoodMaster by telephone (218-782-3419) or by mail at 600 Polk Ave. SW, Red Lake Falls, MN 56750. Please provide the dealer's name, original date of sale, model number and serial number in all communications. WoodMaster reserves the right to require the warranty service to be performed at a WoodMaster facility when deemed necessary by WoodMaster. All corrosion repairs will be performed at WoodMaster unless authorized in writing by WoodMaster.

Design Changes. WoodMaster reserves the right to change and improve the product design for improved performance without assuming responsibility to upgrade previously sold products.