



MAXIM[®]

WOOD PELLET FURNACE

OWNER'S MANUAL

M255 PE



WARNING: If the information in this manual is not followed exactly, a fire or explosion may result causing property damage, personal injury or loss of life.

- Do not store or use gasoline or other flammable vapors and liquids in the vicinity of this or any other appliance.
- **WHAT TO DO IF YOU SMELL GAS**
 - Do not try to light any appliance.
 - Do not touch any electrical switch.
 - Immediately call your gas supplier. Follow the supplier's instructions.
 - If you cannot reach your gas supplier, call the fire department.
- Installation and service must be performed by a qualified installer, service agency or the gas supplier.



0117PS024S
0117PS024E



**SAVE THESE
INSTRUCTIONS**

(p/n 9001006 - REV. B)

MAXIM[®]

WoodMaster, Inc. • 20502 160th Street • Greenbush, MN 56726
WoodMaster.com

The Maxim Wood Pellet Furnace is listed by OMNI-Test Laboratories to the applicable portions of the following standards: UL 2523-2018 Solid Fuel-Fired Hydronic Heating Appliances, Water Heaters and Boilers, CAN/CSA B415.1-10 (R2015) Performance Testing of Solid-Fuel-Burning Heating Appliances, CSA-B366.1-11 (R2015) Solid-Fuel-Fired Central Heating Appliance, ASTM E2618-13 Standard Test Method for Measurement of Particulate Emissions and Heating Efficiency of Solid Fuel-Fired Hydronic Heating Appliances, ASTM E2515-11 Standard Test Method for Determination of Particulate Matter Emissions Collected by a Dilution Tunnel.

The Maxim Wood Pellet Furnace includes two 4-foot stainless steel insulated chimney sections. Use only stainless steel solid fuel chimneys specified by WoodMaster. Maximum draft is marked on nameplate.

French Owner's Manual is available at support.woodmaster.com or upon request from your dealer
(Manuel d'installation en français disponible sur demande auprès de votre revendeur)

MAXIM M255 PE Annual Efficiency Rating*: 96.2% (lower heating value), 89.22% (higher heating value)
Manufacturer's Rated Heat Output Capacity: 190,000 Btu/hr
Thermal Output Rating: 182,504 Btu/hr (53.5 kW) - maximum
Water Capacity: 90 gal. | Weight: 1,297 lbs

*Performance is a product of the combustion rate, combustion efficiency and heat exchange efficiency with a single fuel load without refueling. Results vary based on wood species, wood quality, wood quantity and moisture content. Efficiencies are determined under the same test conditions using higher heating value, lower heating value and annual fuel utilization efficiency (AFUE).

- This heater meets the 2020 U.S. Environmental Protection Agency's cord wood emission limits for wood heaters sold after May 15, 2020. Under specific test conditions this heater has been shown to deliver heat at rates ranging from 0 to 182,504 Btu/hr.
- This wood heater has a manufacturer-set minimum low burn rate that must not be altered. This wood heater needs periodic inspection and repair for proper operation. It is against federal regulations to operate this wood heater in a manner inconsistent with operating instructions in this manual.
- DO NOT OVERFIRE THIS HEATER. Attempts to achieve heat output rates that exceed heater design specifications can result in permanent damage to the heater.
- Any person(s) operating a hydronic heater must comply with all applicable laws, including but not limited to local ordinances.
- Improper use or failure to maintain the hydronic heater may cause nuisance conditions. The person(s) operating a hydronic heater is/are responsible for operation in a manner that does not create a nuisance condition. Meeting the setback distance and stack height recommendations from the manufacturer and requirements in applicable State and local regulations may not always be adequate to prevent nuisance conditions in some areas due to terrain or other factors.
- Operating an outdoor furnace may not be suitable to some individuals' abilities or lifestyles. Be sure to review the Owner's Manual for the appliance with your dealer.

- Register at time of purchase for FREE 5 Year Limited Warranty -

Verify your warranty at: WoodMaster.com/w25

For parts and accessories, service or repairs, call your authorized WoodMaster dealer or heating contractor. Record the information below for future reference.

Model	Serial Number	Installation Date
Dealership Name		Phone Number
Owner Name		

Contents

How to Use This Guide

The guide is divided into sections to help with the operation and maintenance of the outdoor furnace. If questions arise that are not answered with this manual, consult with your authorized WoodMaster dealer.

WoodMaster Online Resources	lv
EPA Resources	lv
Labeling and Terminology	1
Important Precautionary Information	2
Removing from Pallet	4
Shipping Slot Covers	4
Selecting a Location	5
Foundation	5
Levelling the Outdoor Furnace	6
Clearances	6
Electrical - Grounding Rod	7
Access to Ports on Outdoor Furnace	8
Furnace Installation - Connecting to Your Existing System	9
Outdoor Furnace Best Burn Practices	11
Chimney Recommendations	11
Assembling Chimney Transition Box and Insert / Chimney Installation	11
Maxim Chimney Transition Box and Insert	12
Chimney Draft	12
WATER QUALITY AND MAINTENANCE	14
Test Supply Water	14
Add Initial Water Treatment	14
Fill with Water and Purge Air	15
Immediately Start the Pump(s) and Heat the System Water to 185°F (85°C)	16
Test the Treated System Water	17
System Maintenance	19
Water Test Kits and Test Results	19
Flushing the System	21
Adding Antifreeze to Outdoor Furnace System	22
Fuel Selection	23
Fuel Quality and Storage	23
Other Important Information About Fuels	23
Operating Instructions	24
Filling the Hopper	24
Power Up	24
Basic Operation	24
Lighting Instructions	24
Auger Prime	24
Relighting after a Fire Out	25
Operating Precautions	26
Smoke in Hopper	27
Routine Maintenance	28
Maintenance Sections	29
Section 1 - Water Level	29
Section 2 - Ash Removal	29
Section 3 - Firebox	30
Section 4 - Gaskets	31
Section 5 - Heat Exchangers and Chimney Transition	32
Section 6 - Aerator and Burn Chamber	33
Section 7 - Door and Hopper	35
Section 8 - Check Fuel Door Operation	35
Section 9 - Thermal Valve	35
Section 10 - Test Thermal Valve	39
TROUBLESHOOTING	40
GENERAL INFORMATION	46
WIRING DIAGRAM	47

WOODMASTER ONLINE RESOURCES

Enter **WoodMaster.com** in your browser or scan the code using any QR code reader app on your smartphone to access WoodMaster's library of information to help with installation, operation and maintenance of your WoodMaster outdoor furnace.

Detailed Furnace Installation Variations - <https://www.woodmaster.com/furnace-installation/>

View and/or download PDFs to assist in installation of your outdoor furnace. Information and examples regarding pumps, foundations, chimneys and support structures, ThermoPEX piping, and example configurations for a variety of heating configurations.



Online Support Center



<https://support.woodmaster.com>

Enter your furnace serial number and find articles, answers, parts and more information.



Online Support Center

support.woodmaster.com
Enter your serial number for information specific to your furnace.

Write your *serial number* here for future reference.



Videos to supplement the Owner's Manual are available at www.youtube.com/@WMfurnaces
Watch tips on initial startup, testing system water and more.

EPA RESOURCES

EPA's Burnwise Program - <https://www.epa.gov/burnwise>

NOTE: The warranty can be voided by operating a residential hydronic heater in a manner inconsistent with the Owner's Manual.

INSTALLATIONS IN MASSACHUSETTS:

1. All installation components must be products approved in the Commonwealth of Massachusetts by the Gas and Plumbing Board.
2. The maximum run of tubing from the water heater to a fan coil is 50 linear feet.
3. Persons operating this hydronic heater are responsible for operation of the hydronic heater so as not to cause a condition of air pollution as defined in 310 CMR 7.01(1).

Labeling and Terminology

The outdoor furnace and this guide use the following terms and symbols to bring attention to the presence of hazards of various risk levels and important information concerning the use and maintenance of the outdoor furnace.

⚠ DANGER

This symbol and text indicate an imminently hazardous situation which, if ignored, will result in death or serious injury.

⚠ WARNING

This symbol and text indicate the presence of a hazard which can cause severe personal injury or death to an operator or bystander, or substantial property damage if ignored.

⚠ CAUTION

This symbol and text indicate the presence of a hazard which can cause minor personal injury or property damage if ignored.

NOTE: Indicates supplementary information worthy of particular attention relating to installation, operation, or maintenance of the outdoor furnace but is not related to a hazardous condition.

Be sure to follow all instructions and related precautions as they are meant for your safety and protection. Store this manual in a readily accessible location for future reference.

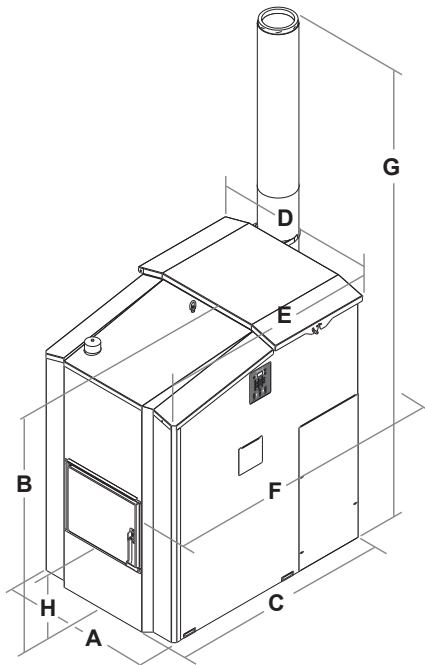

Maxim M255 PE Measurements								
	A	B	C	D	E	F	G	H
in.	34	57	49.5	36	48	59.5*	117.5**	14.5
cm	86	145	126	91.5	122	151*	298.5**	37

* Measurement (F) is from firebox door to chimney inspection cover.
 ** Measurement (G) with two 4-foot chimney sections.

Important Precautionary Information

Be sure to read carefully and understand these precautions before, during and after the installation, operation and maintenance of the furnace.

NOTE: All operations must be in accordance with local and state codes which may differ from the information in this manual.

NOTE: Installation of the outdoor furnace is to be performed by a qualified installer.

NOTE: Check with your insurance company to see if they have any location requirements.

NOTE: Any changes to an existing boiler should be done by a qualified installer in accordance with applicable codes.

NOTE: Do not connect this outdoor furnace to a chimney flue serving another appliance.

⚠ CAUTION

This outdoor furnace is not intended to be the only source of heat. In the event of a prolonged power failure, a generator may be used to prevent lines from freezing. Should the outdoor furnace be left unattended, run out of fuel or require service, an alternate heating source in the building being heated should be in place to prevent damage caused by freezing.

⚠ WARNING

This outdoor furnace is not intended or certified to be installed inside habitable space. Do not install the outdoor furnace inside your home.

NOTE: If installed in a non-habitable building, adequate combustion air and ventilation must be provided.

⚠ WARNING

This outdoor furnace and/or chimney is not intended or safety tested to be used or installed in a building where contents of that building could be damaged or where a financial loss could occur from smoke, soot, fire or water.

⚠ WARNING

This outdoor furnace and/or chimney must not be installed inside or under any configuration or construction that contains combustible materials as part of the structure or configuration. The chimney is not intended or safety tested to be used or installed other than on the furnace located outside of any structure or enclosure.

⚠ CAUTION

This outdoor furnace is not to be connected to a chimney flue serving another appliance.

⚠ WARNING

The outdoor furnace vent cap must fit loosely on the vent opening. Do not force the cap down or try to seal it tightly onto the vent pipe. Do not extend or restrict the vent pipe or opening. **DO NOT ALLOW THE OUTDOOR FURNACE TO BE PRESSURIZED.**

⚠ WARNING

Be sure the outdoor furnace is filled with water before firing. Water level is safe when the water level indicator rod is above the vent cap. MolyArmor 350 must be added before the initial fill (see Water Quality and Maintenance).

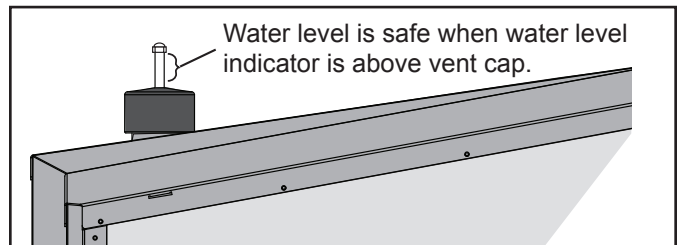

⚠ WARNING

Disconnect the electrical power to the outdoor furnace and remove all ash from the firebox before performing maintenance that requires draining the water or replacing an electrical component.

⚠ WARNING

Do not attempt service inside the electrical control panel without first disconnecting the electrical power at the main power source.

NOTE: Any electrical installation should be done by a qualified installer in accordance with applicable codes.

⚠ WARNING

Allow the outdoor furnace to thoroughly cool and completely clean out the firebox before draining water from the outdoor furnace. If the water in the outdoor furnace ever boils, be sure to check the water level and restore to full. If water is added, the proper level of MolyArmor 350 Corrosion Inhibitor (p/n 2900630) must be maintained.

⚠ WARNING

Use only chimneys listed to UL 103 HT for installation. The chimney and flue pipe must be clean and in good condition.

⚠ WARNING

When cleaning the outdoor furnace, be careful not to spill any hot ash.

⚠ WARNING

ALWAYS store ash in a covered non-combustible container.

⚠ WARNING

Maintain the following clearances from combustibles for the furnace installation:

- 8" (20 cm) from the transition box
- 6" (15 cm) from the sides
- 48" (122 cm) from the front
- 8" (20 cm) from the chimney
- 27" (68.5 cm) from the top
- The foundation must be noncombustible

⚠ WARNING

Do not allow combustible materials (straw, hay or wood) near the outdoor furnace. Keep the perimeter of the outdoor furnace clear and clean.

⚠ WARNING

All covers must be maintained at all times except during maintenance, inspection and service.

⚠ WARNING

Never leave the firebox door or hopper lid open or ajar when unattended.

⚠ WARNING

This heater is designed to burn premium quality wood pellets only.* Higher efficiencies and lower emissions generally result when burning premium quality wood pellets, as compared to standard pellets. **DO NOT BURN:** unseasoned wood, garbage, tires, lawn clippings, leaves, brush trimmings or general yard waste, materials containing asbestos, materials containing lead, mercury or other heavy toxic metals, materials containing plastic, materials containing rubber, waste petroleum products, paints and paint thinners, asphalt products, chemicals, coal, glossy or colored paper, construction and demolition debris, plywood, particleboard, salt water driftwood and other previously salt water saturated materials, manure, animal carcasses and asphalt products. Burning these materials may result in release of toxic fumes or render the heater ineffective and cause smoke.

⚠ WARNING

Use only those listed fuels recommended by the manufacturer of your unit. Never use the following: trash, plastics, gasoline, rubber, naphtha, household garbage, material treated with petroleum products (particle board, railroad ties and pressure treated wood), leaves, paper products, and cardboard.

⚠ CAUTION

Never use gasoline, gasoline-type lantern fuel, kerosene, charcoal lighter fluid, or similar liquids to start or 'freshen up' a fire in this outdoor furnace. Keep all such liquids well away from the outdoor furnace while it is in use.

NOTE: Chloride or sulfurous gases can be generated if plastic or rubber is burned and will mix with the moisture from the wood and form hydrochloric or sulfuric acids in the firebox, creating corrosion.

⚠ CAUTION

Always wear the appropriate personal protective gear when cleaning ash from the firebox.

⚠ CAUTION

Failure to maintain and clean heat exchangers properly can result in the thermal valve activating.

NOTE: At least one circulation pump must run continuously to ensure proper operation of the outdoor furnace.

Options for Increasing Fuel Storage

An optional 48-Bushel Hopper is available (p/n 9660 or 9760) for increasing fuel storage. This hopper can be positioned to the side of the furnace using a 5-1/2' Auxiliary Auger Kit (p/n 9440).

A 6' Auxiliary Auger Kit (p/n 6453) and an 8' Auxiliary Auger Kit (p/n 9454) are also available for other applications. The auxiliary augers can also be used with larger external bins.

An optional Auxiliary Auger Vibrator with Timer Kit (p/n 9458) can be installed on the auxiliary auger connected to an external hopper. Vibration occurs based on a timer setting.

Tools/Ground Rod Kit

Included with each new furnace are tools that are invaluable for maintenance and cleaning and a Ground Rod Kit for electrically grounding the furnace. Use the **flue brush kit** to clean the flue passageways. The **cleaning rod** can be used to clean the firebox. It is also used to clean the heat exchangers.

Refer to the Maintenance section for more information.

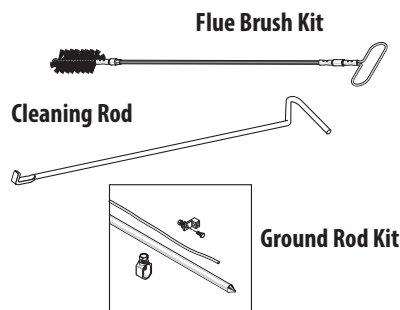

Removing from Pallet

The outdoor furnace is secured to the shipping pallet with four brackets. To remove these brackets, loosen (but do not remove) the two screws securing each shipping slot cover and slide the cover up. Remove the bolts securing the bracket to the pallet and remove the bracket.

NOTE: Lift the outdoor furnace only where specified in the illustration.

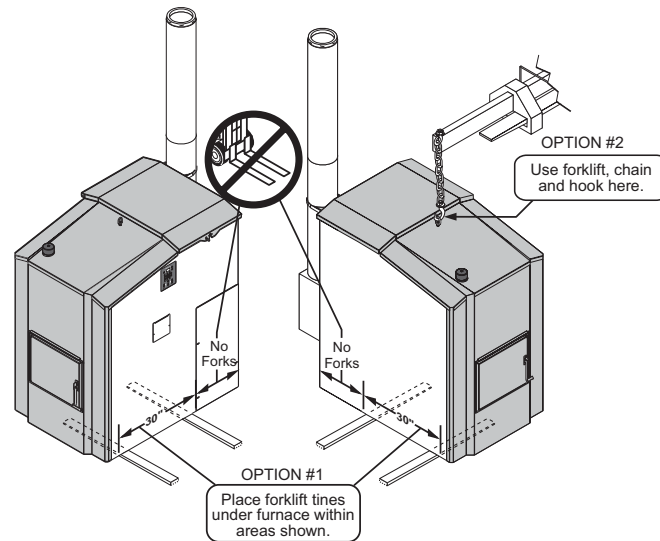

Shipping Slot Covers

Position each shipping slot cover so it is flush with the bottom of the outdoor furnace; then secure the cover by tightening the two screws. Make sure all four covers are properly positioned and secured.

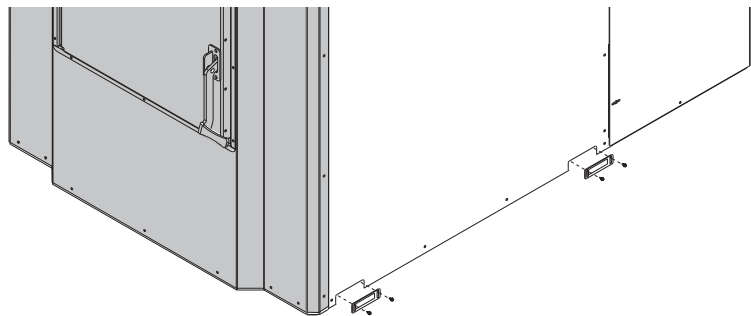

Selecting a Location

To ensure the Maxim Furnace functions as designed, careful planning and proper installation are imperative. If any installation questions arise that cannot be answered by the information in this manual, be sure to contact your dealer.

When selecting a suitable location, carefully consider each of the following:

- ❑ Must be installed in accordance with all applicable codes and regulations.
- ❑ A qualified installer must perform the installation of this supplementary outdoor furnace and must determine how to install it to be compatible with the existing heating source.
- ❑ Consider prevailing winds and the direction exhaust from the chimney will travel.
- ❑ The shorter the distance between the outdoor furnace and building(s) being heated, the lower the cost will be for the installation of the hot supply and return water lines and insulation.
- ❑ Be sure to maintain the required clearances to combustibles and recommended maintenance clearances.
- ❑ ThermoPEX pre-insulated piping is recommended for all underground installations. Other types of piping should not be buried in low-lying areas with standing water or with a very high water table, or under an area of heavy vehicle traffic unless protected from excessive compression.

Foundation

The outdoor furnace may be installed directly on **stable, level ground** without the necessity of a foundation. If the ground is unstable, one option is to use patio blocks, bricks or pavers under the base. Another option is to pour a concrete foundation. If installing on an existing slab, it may be necessary to use patio blocks, bricks or pavers to allow access to the water lines.

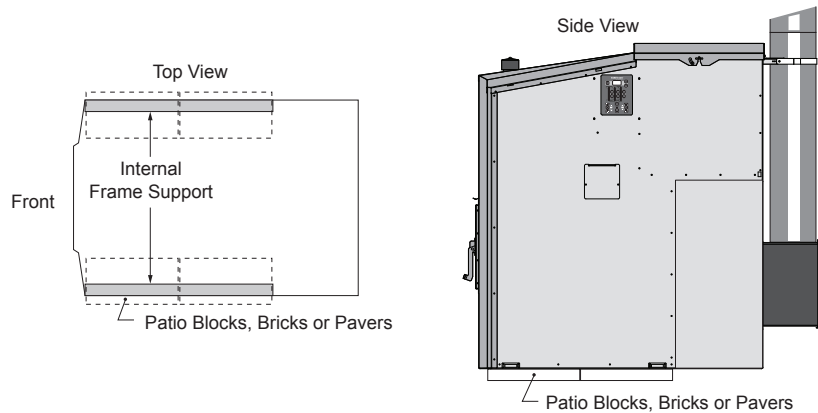

To install the outdoor furnace on a concrete foundation, account for the location of the hollowed-out area. A 4" to 6" (10 cm to 15 cm) thick concrete slab works well; however, a thicker slab may be used to obtain the desired firebox door opening height.

Maxim Furnace Base Dimensions

Furnace Base Dimensions

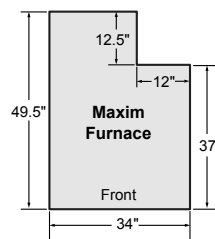

Optional 48-Bushel Hopper with Furnace Base Dimensions

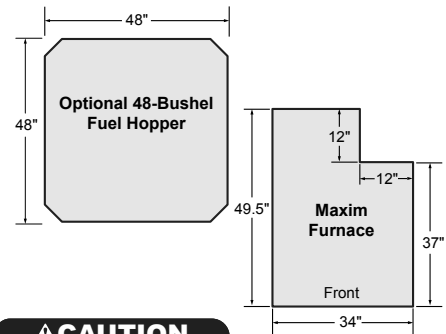

NOTE

Furnace must be installed on a noncombustible surface or foundation that incorporates an enclosure that will prevent supply and return lines from possible exposure to sunlight, fire, or physical damage that may be caused by an occurrence outside the furnace enclosure.

CAUTION

Do not use any combustible materials for the foundation.

NOTE: In all installations, the outdoor furnace must not be operated with the back panels removed. Make necessary allowances for access to the back of the outdoor furnace.

If the area for the concrete slab is unstable or subject to frost heaving, consider installing 2" closed-cell insulation under the front portion of the concrete slab the outdoor furnace will be installed on, and under the area around the slab used for walking.

Maxim Leveling Procedure

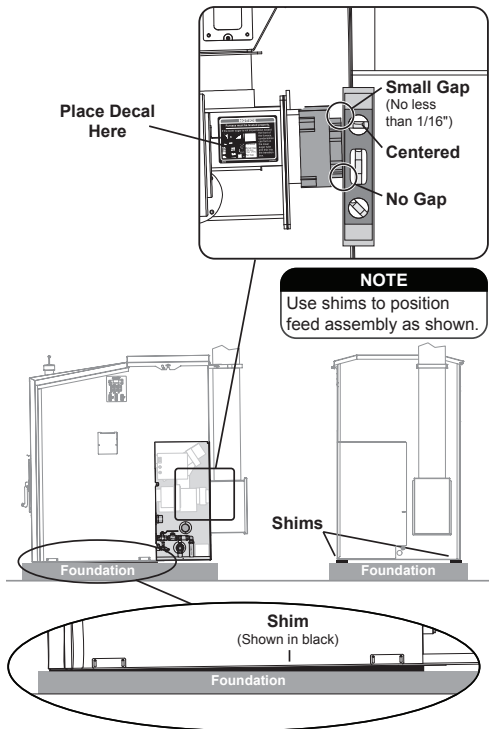

Levelling the Outdoor Furnace

⚠ CAUTION

The back of the furnace must not be lower than the front of the furnace.

The Maxim should be leveled so that the back of the transition box (i.e., the burner auger motor end) is slightly higher than the front. Smoke can condense into creosote inside the burner auger tube. If the burner auger is not sloped down toward the front of the furnace, condensation can form in the burner auger tube and drip into the transition box.

⚠ WARNING

Disconnect the electrical power at the main power source.

1. Disconnect the electrical power at the main power source.
2. Remove the access panels from the back corner of the furnace and set aside.
3. Place a level on the back of the burner auger motor as shown. The back of the transition box should be slightly higher than the front, indicated when the level is vertical and there is a small gap (from 1/16" to 3/32", or 1.6 mm to 2.4 mm) between the level and the top of the burner auger motor and no gap between the level and the bottom of the burner auger motor.
4. Use shims as necessary under the outdoor furnace in the locations shown until the procedure in Step 3 indicates that the back of the transition box is slightly higher than the front.

NOTE: Periodically check that the outdoor furnace is leveled as described in these instructions because frost can cause the foundation to move.

5. Install the access panels on the back corner of the furnace.
6. Connect the electrical power at the main power source.

Clearances

NOTE: Clearance to combustibles from the chimney transition box is 8" (20 cm); HOWEVER, if installing with the back of the furnace facing an immovable wall, object, etc., you must maintain 36" (91.5 cm) of clearance to perform periodic maintenance.

⚠ WARNING

Maintain the following clearances from combustibles for the installation:

- 8" (20 cm) from the transition box
- 6" (15 cm) from the sides
- 48" (122 cm) from the front
- 8" (20 cm) from the chimney
- 27" (68.5 cm) from the top
- The foundation must be noncombustible

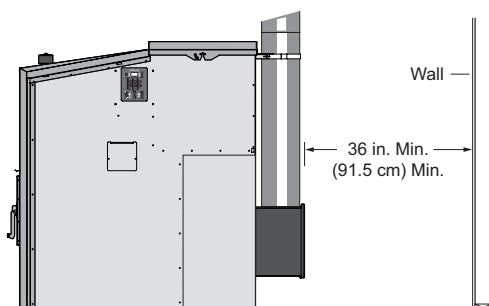

Electrical - Grounding Rod

NOTE: Any electrical installation should be done by a qualified installer in accordance with applicable codes.

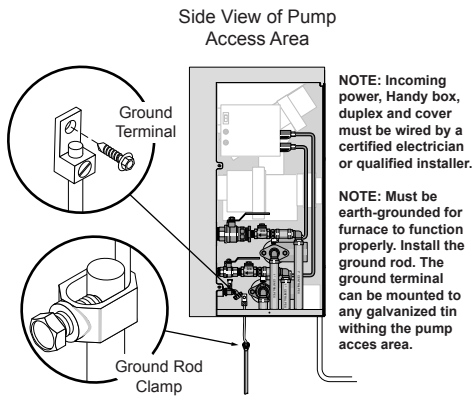

The outdoor furnace must be electrically bonded to ground in accordance with the requirements of the authority having jurisdiction or, in absence of such requirements, with the National Electrical Code, ANSI/NFPA 70 and/or the Canadian Electrical Code Part 1, CSA C22.1 Electrical Code.

Install the ground rod included with the outdoor furnace and connect it to the outdoor furnace.

1. In the water line trench near the outdoor furnace, drive the ground rod into the ground until the top of the ground rod is below the ground surface.
2. Remove the side and back panels; then route the ground wire from the ground rod under the outdoor furnace base and over to the bottom left corner at the back of the outdoor furnace.
3. Secure the ground terminal with the self-drilling screw provided. Secure the ground wire to the terminal; then secure the ground wire to the ground rod with the clamp. Tighten all hardware securely.

Ignitor Operation - Ignition Sequence

The ignition sequence follows a control logic to ensure safe and effective ignition. The ignition sequence is as follow:

1. The water temperature must be low enough for the furnace to shift into demand mode.
2. The fan will start and operate at the ignition fan speed and the Firestar control will send voltage to the igniter relay.
3. The air proving switch will close, completing the ignition relay control circuit.
4. The electric ignitor will warm up and heat the air blowing across it into the burn chamber.
5. The auger will cycle periodically to feed the required amount of fuel into the burn chamber, and to agitate any pellets already present in the burn chamber.
6. The ignitor will operate until the burn chamber reaches a temperature that is high enough to sustain itself, or for ten minutes, at which time the ignitor will turn off.

Access to Ports on Outdoor Furnace

Access to the hot supply and return ports is gained by removing the access panels on the lower right-hand side and back of the furnace. There are two hot supply and two return ports on the furnace. This configuration allows for mounting the circulation pumps on the furnace.

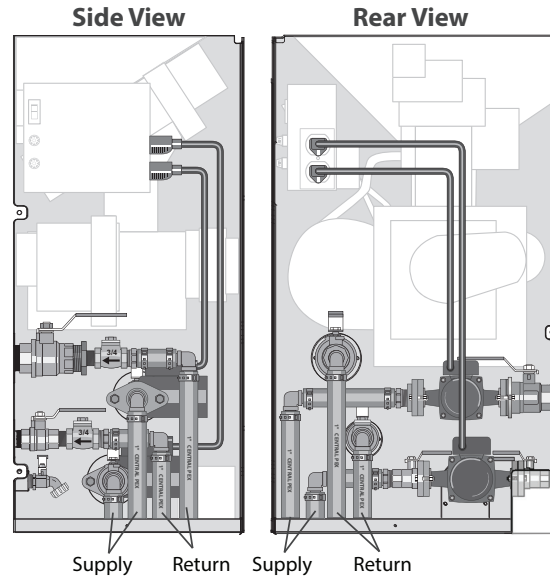

NOTE: At least one circulation pump must run continuously to ensure proper operation of the outdoor furnace.

There are eight knock-out tabs on the floor panel of the furnace to accommodate the water lines. These align with the hollowed-out area in the foundation specifications. The pump access area in the back right corner must align with the blocked out area of the foundation.

NOTE: The Installation Guide provides more information on pump selection. For even more detailed information, see the Hydronic Component Selection Guide (p/n 2482), available from your WoodMaster dealer.

Maxim with Wrap-around-pump Installed

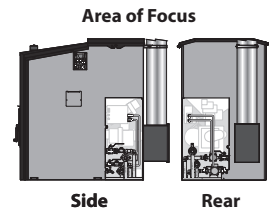
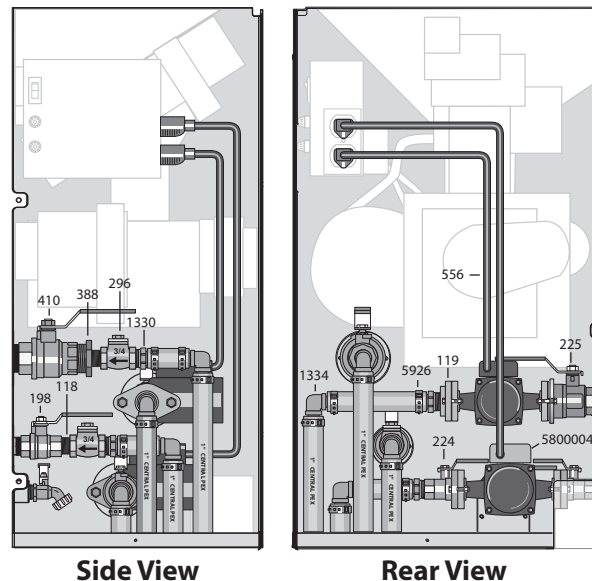

Parts List	
Qty	p/n Description
2	118 Close Nipple, 3/4"
1	119 Pump Flange Kit, 3/4"
1	198 Ball Valve, 3/4"
1	224 Isolation Flange, 3/4"
1	225 Isolation Flange, 1-1/4"
2	296 Swing Check Valve, 3/4"
1	388 Hex Bushing, 1-1/4" x 3/4"
1	410 Ball Valve, 1-1/4"
2	556 Power Supply Cord, 32"
4	1330 PEX Adapter, 1" x 3/4"
4	1334 PEX 90° Elbow, 1"
12	5926 Stainless Steel Clamp, 1"
2	5800055 Pump

Parts and accessories sold separately. Pump size may vary.

Furnace Installation - Connecting to Your Existing System

Detailed Furnace Installation Variations

Visit WoodMaster.com to access a library of detailed illustrations for connecting to a wide variety of existing heating systems and for other heating options.

A common installation is to connect the outdoor furnace to an existing water heater and then to an existing forced air system. A water-to-air heat exchanger is mounted in the plenum or duct work of the existing furnace. Heated water from the outdoor furnace either continuously flows through the water-to-air heat exchanger or is diverted through a 3-way zone valve. When the thermostat senses the need for heat, the fan on the existing furnace forces air through the heat exchanger, transferring heat throughout the existing ductwork.

NOTE: There are numerous ways to connect to your heating system. Refer to the **WoodMaster Outdoor Furnace Installation Guide** for other installations.

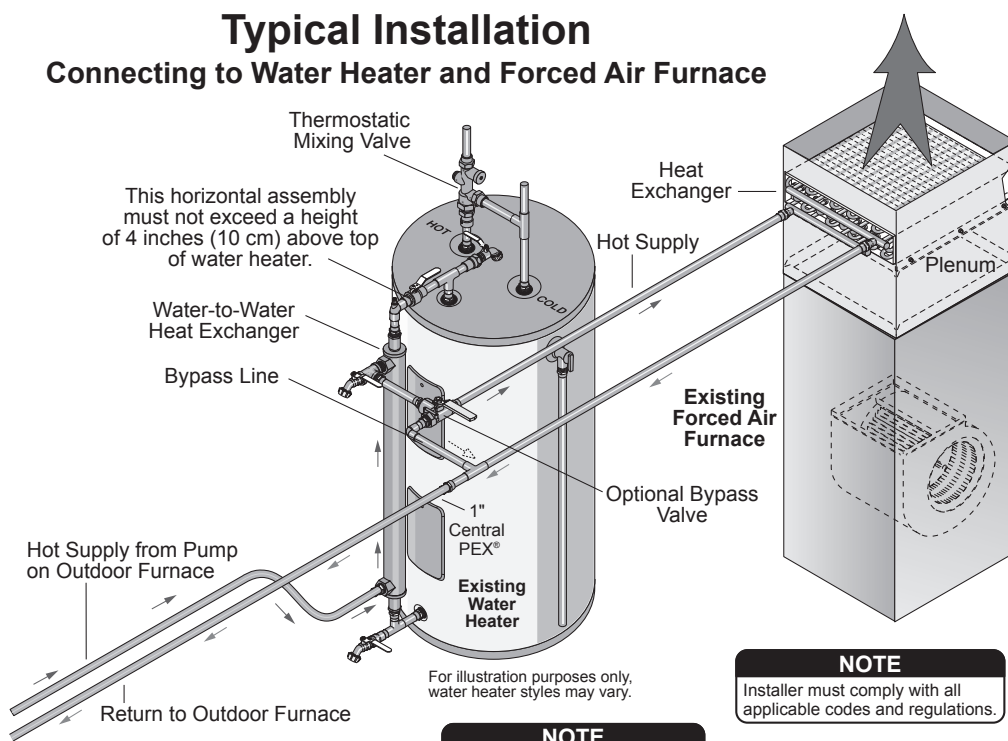

NOTE: A certified electrician must do the electrical installation.

NOTE
Any electrical installation should be done by a qualified installer in accordance with applicable codes.

NOTE
Installer must comply with all applicable codes and regulations.

Remote Thermal Storage Installation Connecting to Remote Thermal Storage Tank

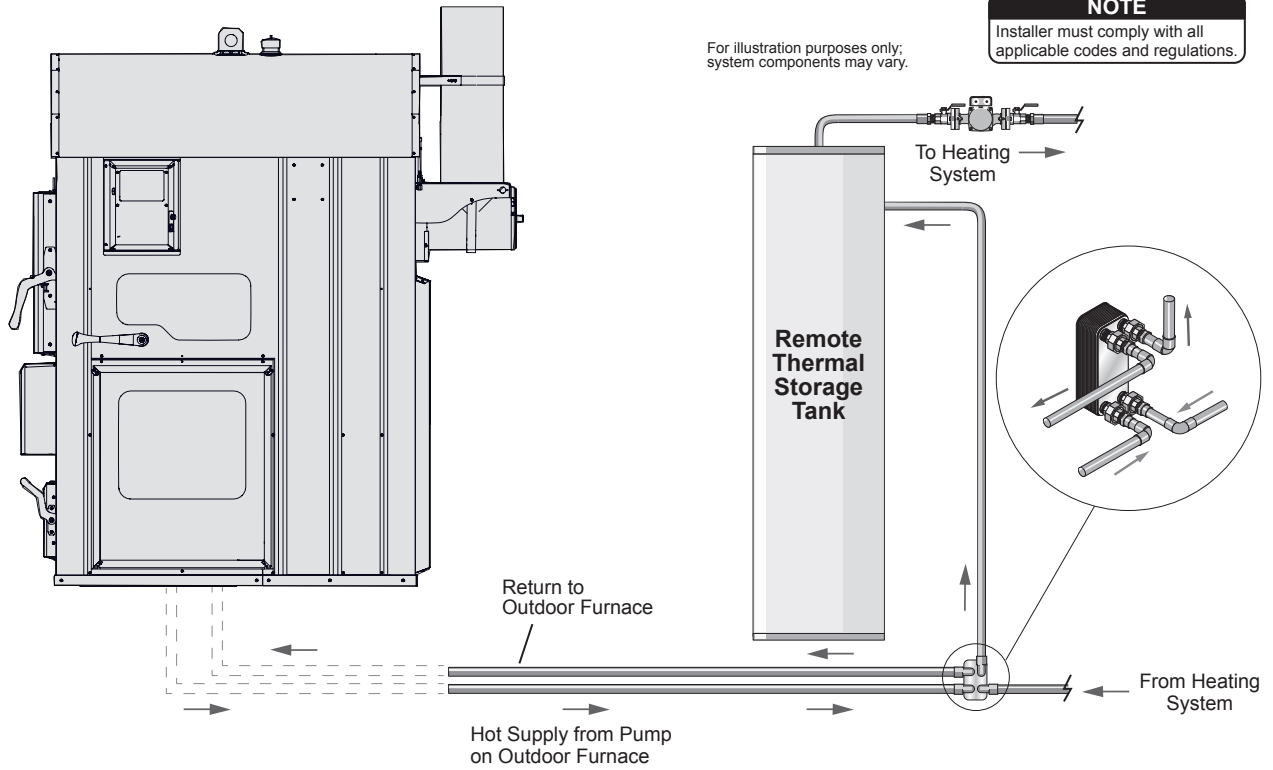

NOTE
Installer must comply with all applicable codes and regulations.

For illustration purposes only; system components may vary.

Outdoor Furnace Best Burn Practices

1. Read and follow all operating instructions supplied by the manufacturer.
2. FUEL USED: Only those listed fuels recommended by the manufacturer of your unit. Never use the following: trash, plastics, gasoline, rubber, naphtha, household garbage, material treated with petroleum products (particle board, railroad ties and pressure treated wood), leaves, paper products, and cardboard.
3. LOADING FUEL: For a more efficient burn, pay careful attention to loading times and amounts. Follow the manufacturer's written instructions for recommended loading times and amounts.
4. STARTERS: Do not use lighter fluids, gasoline, or chemicals.
5. CHIMNEY RECOMMENDATIONS: In higher populated areas, extend the chimney to a height above the roofs of surrounding buildings.
6. Always remember to comply with all applicable state and local codes.

Be considerate of neighbors when operating your furnace. If you use your furnace in the summer months, be certain your chimney exhaust is not adversely affecting neighbors with open windows.

Chimney Recommendations

In higher populated areas, extend the chimney to a height above the roofs of surrounding buildings. Use WoodMaster Chimney Extensions when extending the chimney. When only the standard eight feet (2.4 m) of chimney are used, the sections must be secured at the connection joint with four (4) screws to stabilize the extension.

Assembling Chimney Transition Box and Insert / Chimney Installation

NOTE: Instructions are also provided with the furnace. For these steps, refer to the illustration on the next page.

1. Place the Chimney Transition Box into position on the back of the furnace. Secure with hardware provided.
2. Using the #8-18 x 1/2" Self-tapping Screws provided, assemble the Chimney Transition Box Insert sides to the insert top and insert bottom as shown in Fig. 1. The screws are installed from the inside. Make sure the insert sides are assembled inside the flanges on the insert top and bottom and the flanges on the insert sides are positioned to the outside. The hole on the insert top must be positioned toward the back as shown.
3. Cut the 2-foot length of foil tape provided into six pieces approximately 4" long each. Wrap the assembled Chimney Transition Box Insert with the insulation as shown.
4. Secure the top and rear edges of the insulation to the assembly with the pieces of foil tape. The tape will hold the insulation in place when the insert is installed in the chimney transition box.
5. Carefully slide the assembly with insulation into the Chimney Transition Box.
6. Using the screws provided, install the latch to the bottom of the chimney box as shown.
7. Install the Chimney Transition Box Cover and secure with the latch.

Maxim Chimney Transition Box and Insert

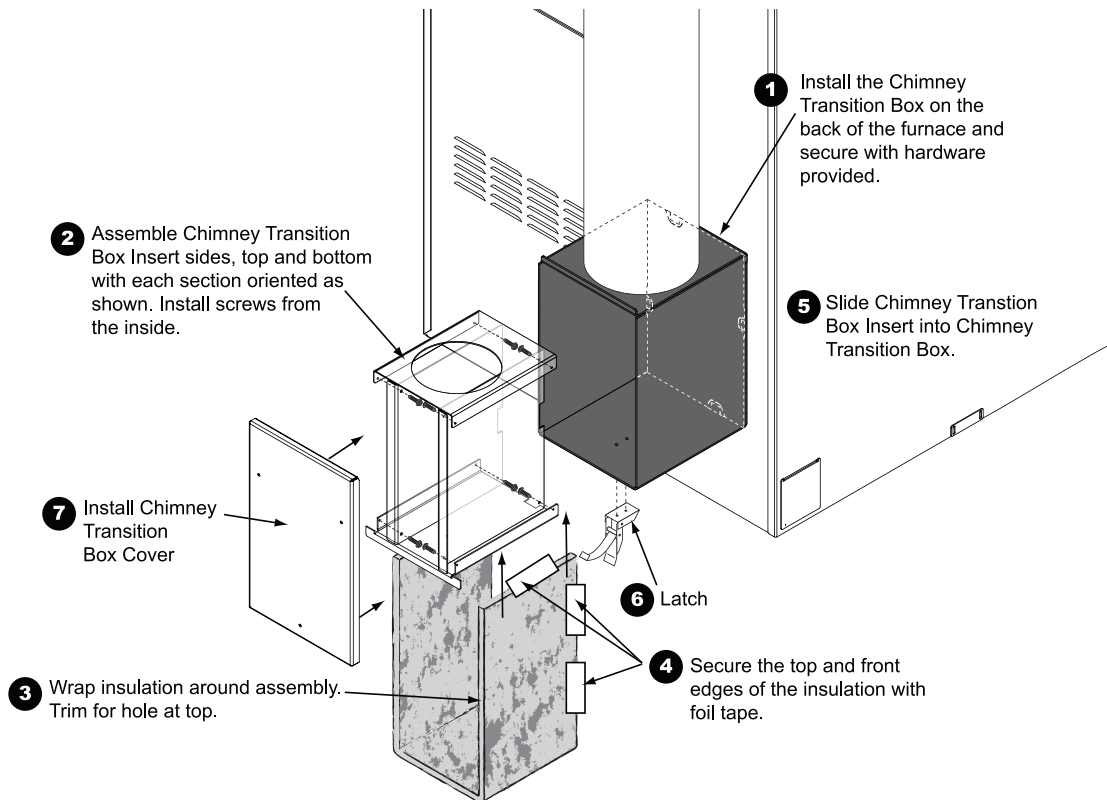

Chimney Draft

Proper draft is necessary for the Maxim to operate optimally. Draft occurs when the temperature in the chimney is high enough and/or the chimney is high enough to cause a negative pressure that "pulls" the exhaust up and out the chimney. The higher the burn rate and fan settings, the more sections of chimney that will be required to provide proper draft.

NOTE: Adding more chimney sections increases the amount of negative pressure in the chimney.

NOTE: A qualified installer may perform the following test to check for proper draft.

1. Drill a hole in the chimney inspection cover; then with the outdoor furnace and chimney at normal operating temperature, use a manometer to check draft. Flue draft should be between -0.02 in. WC (-5 Pa) and -0.05 in. WC (-12.45 Pa). If the flue draft is lower, add more chimney sections.
2. After the test, fill the hole in the chimney inspection cover with high-temp silicone.

3. If a spark arrestor is being used, make sure it is clean and unobstructed.
4. Objects like buildings and trees in close proximity or nearby terrain (e.g., hills, valleys, etc.) can adversely affect air flow in the chimney. Adding chimney sections may overcome these factors.

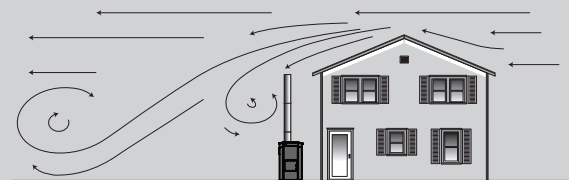

May cause poor draft.

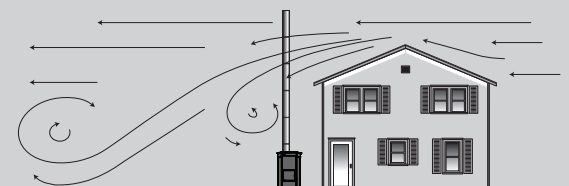

Allows for better draft.

If extensions are added to the standard eight feet (2.4 m) of chimney, the chimney should be reinforced appropriately. The illustration shows chimney support recommendations when three or more sections are used. When adding sections of chimney, make sure that there is nothing within the fall zone of the chimney that could be damaged. If something is located within the fall zone and cannot be removed, guy wires or braces may need to be installed to prevent a falling chimney from causing damage.

NOTE: If more than three 4-foot (1.2-m) sections of chimney are used, a support (e.g., a pole, pipe or other structural support) may be installed from the ground that can withstand wind. Other reinforcement recommendations are shown.

NOTE: For chimney extensions or chimney replacement, use only genuine WoodMaster chimney components. Parts are available from an authorized WoodMaster dealer.

The installation of a spark arrestor is recommended, particularly where there are dry conditions or where there is combustible material near the unit, unless the installation of a spark arrestor is prohibited by local requirements.

NOTE: If the screen is left on the chimney cap, the spark arrestor should be inspected and cleaned as needed.

Use common sense to avoid potential fires, including exercising caution when disposing of ashes, cleaning and refueling. Keep all highly combustible materials (e.g., gasoline, propane, leaves, pine needles, etc.) away from an operating unit at all times. Take special precautions in windy conditions.

NOTE: You may need to increase the chimney height if conditions occur that force exhaust to low levels.

Chimney Reinforcement Recommendations for Maxim M255 Models

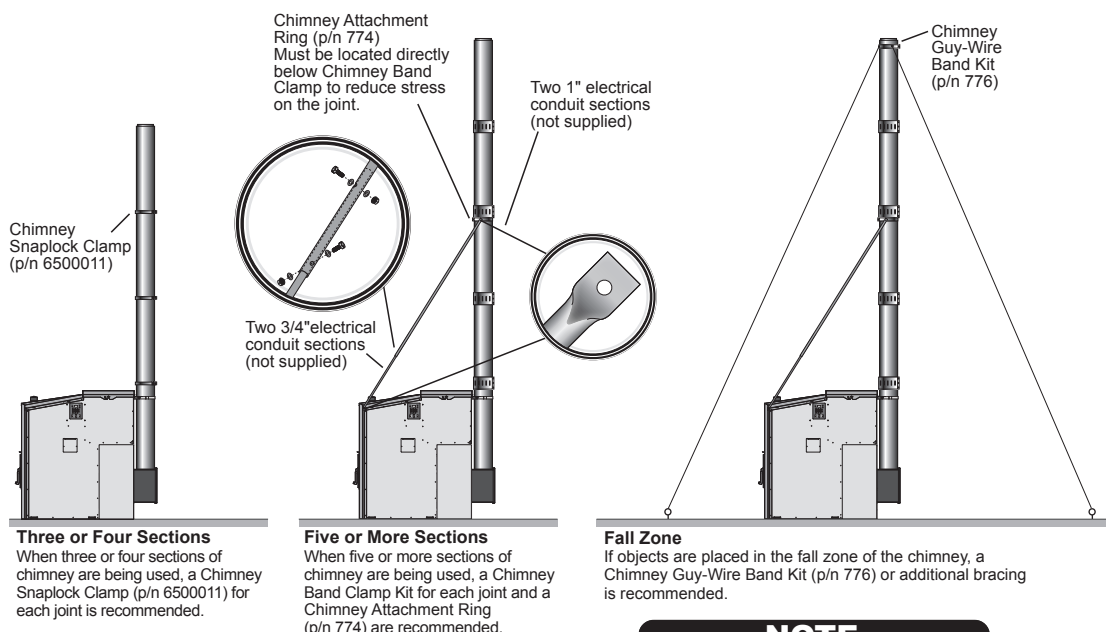

NOTE

- Additional bracing may be necessary in certain areas such as those subject to severe weather, winds, freezing rain, etc.
- Inspect all bracing bi-annually for integrity.

WATER QUALITY AND MAINTENANCE

Test Supply Water

Test a sample of the supply water (makeup water) that will be used to fill the outdoor furnace (softened water is recommended). Test strips for testing pH are included in the water test kit which is provided with the outdoor furnace.

1. Collect a small sample of the water to be used to fill the outdoor furnace in a clean container.
2. Dip a test strip from the test kit in the water sample for **1 second** and remove. Shake off excess liquid (very important to prevent water bleed from one pad to the other). Compare the pH test pad to the color chart at **30 seconds**.
3. If the pH level is between 6.5 and 8.0 and there are no other known water quality problems, then the outdoor furnace may be filled with this water.
4. Water that has a pH level of less than 6.5 or greater than 8.0, or that has other known water quality problems, should not be used to fill the furnace. Instead, water should be supplied from a different source.

Add Initial Water Treatment

⚠ CAUTION

Avoid damaging your furnace and voiding your warranty. Add water treatment BEFORE adding water to the system. Water treatment in your outdoor furnace is just as important as the oil in a car's engine.

MolyArmor 350 Corrosion Inhibitor (p/n 2900631) gives optimum protection for the furnace water jacket and system parts when it is used to initially treat the water and is maintained at a minimum of 350 ppm of moly and pH level between 8.0 and 9.5. One unit of MolyArmor 350 is a 1-gallon (3.78-liter) container.

MOLYARMOR 350 TREATMENT AMOUNTS	
Maxim M255 PE	1 gallons

Add the recommended amount of MolyArmor 350 to the outdoor furnace.

NOTE: If the system has a larger than normal water capacity, more MolyArmor 350 should be added at a recommended rate of 6.5 oz. (190 ml) per 10 gallons (37.8 liters) of system water. One unit (1 gallon or 3.78 liters) of MolyArmor 350 will treat 200 gallons (757 liters) of system water.

Fill with Water and Purge Air

NOTE: If adding antifreeze to the system, refer to **Adding Antifreeze to Outdoor Furnace System** section for important information.

⚠ CAUTION

If using antifreeze, use only a nontoxic boiler-type antifreeze. It is imperative that the entire system contain at least 30% antifreeze concentration mixed with water that is 6.5 to 8.0 pH. Softened water is recommended, if available. Do not use reverse osmosis or deionized water that has very low pH. Be sure to adhere to all warnings and precautions on the antifreeze label.

NOTE: If the outdoor furnace is being filled with water when the temperature is below freezing, circulate the water immediately after filling to prevent freezing the water lines.

NOTE: The circulation pump(s) must be installed in the hot supply line(s).

NOTE: All air must be purged from the water lines when filling the system. Be sure to purge the air from each pump circuit from the outdoor furnace.

NOTE: All valves in the outdoor furnace system should be opened before starting this procedure.

1. Connect a garden hose to the water source to be used to fill the outdoor furnace. Purge the garden hose of any impurities by running water through it until the water is clear.
2. Connect the hose to the drain valve on the outdoor furnace. Open the drain valve and fill with water to thoroughly mix the MolyArmor 350, which is heavier than water.

NOTE: If purging air from the system lines is necessary after the initial treatment with MolyArmor 350 and water has been added, use a transfer pump and the procedure provided in the Installation Guide. That procedure can be used to purge the system without diluting the system mixture.

Immediately Start the Pump(s) and Heat the System Water to 185°F (85°C)

⚠ CAUTION

Be sure the outdoor furnace is filled with water before firing. Water level is safe when the water level indicator rod is above the vent cap. MolyArmor 350 must be added before the initial fill.

1. Start the pump(s). Refer to Initial Fire Up - Start of Heating Season to start the outdoor furnace. Bring the water temperature up to operating temperature (185°F or 85°C) for two hours with the system circulating; then add water to the full mark. Continue to run the pump and circulate the water for 24 hours.

NOTE: It is important to bring the water in the system up to operating temperature (i.e., 185°F or 85°C) immediately after filling the system. This also applies any time water is added to the system.

NOTE: If there are multiple circuits connected to the outdoor furnace, repeat the process for each circuit.

⚠ CAUTION

The water in the system may be hot. Use caution and the appropriate personal protective equipment (PPE) when checking for leaks.

2. Check the system for leaks. Inspect all fittings and hose ends for any signs of leakage. Use several dry paper towels and wrap them around and squeeze each fitting, valve and pipe connection. The paper towels will get wet even if there is a very small leak. Immediately repair any leaks to eliminate the need for adding water. If a screw-type clamp has been used, it may be possible to stop a very slow leak at a hose clamp by tightening the clamp after the system has warmed up and the poly becomes more pliable. It might also be necessary to install a second hose clamp with the screw positioned on the opposite side.

NOTE: After a week of operating, use the procedure in step 2 to check the system for leaks again.

NOTE: If water is added, it is important to bring the water in the system up to operating temperature (i.e., 185°F or 85°C) immediately. Refer to the instructions provided in the test kit for water testing procedures. If indicated by test results, add MolyArmor 350 as required. Deterioration due to improper operation and/or maintenance is not covered by warranty.

Test the Treated System Water

After circulating the water in the system for at least 24 hours, test the treated system water for the recommended moly (at least 350 ppm) and pH level (between 8.0 and 9.5).

⚠ CAUTION

The water collected may be hot. Use caution when obtaining a sample.

A treated water sample from the outdoor furnace can be obtained either from the valve on the hot water heater or from the furnace drain valve.

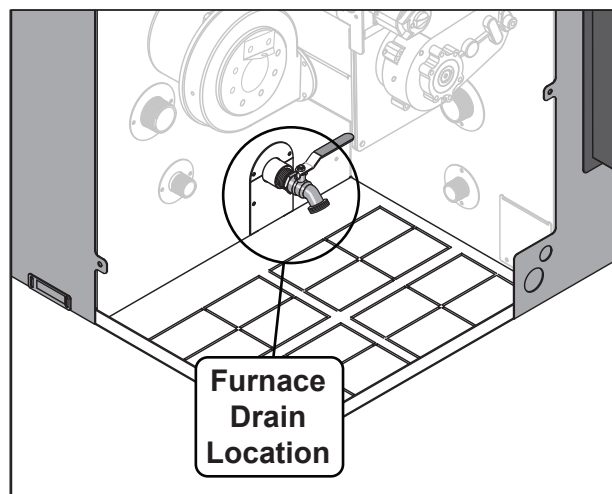
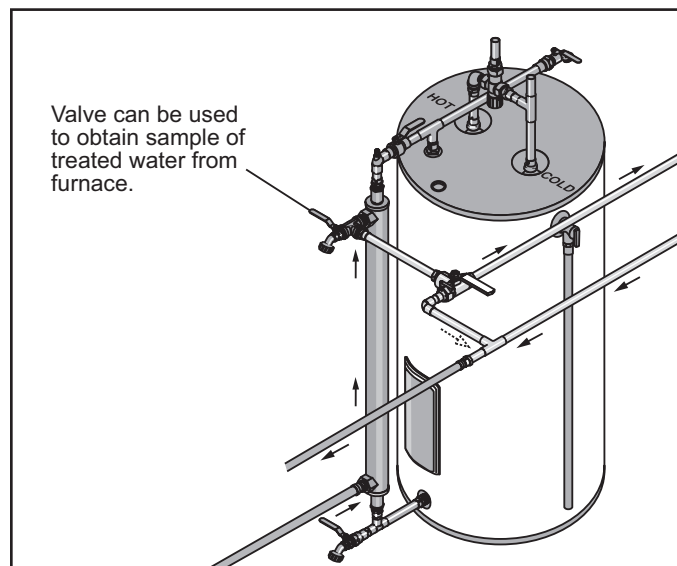

1. Before collecting the sample, drain about a quart (liter) of water; then carefully fill the sample container without contaminating the sample. **Be sure to properly close the valve when finished.**
2. Dip a test strip from the test kit in the water sample for **1 second** and remove. Shake off excess liquid (very important to prevent water bleed from one pad to the other). Compare moly test pad to the color chart within 10 seconds. The moly level must be **350 ppm or more.**
3. Compare pH test pad to the color chart at **30 seconds.** The pH of the treated water should be **between 8.0 and 9.5.** If the pH is higher than 10.0, dilute the water in the furnace by draining approximately 1/4 of the water from the furnace. Add MolyArmor 350 and refill with water that has a pH between 6.5 and 8.0. After refilling, circulate the water with furnace at operating temperature for at least 24 hours and test to confirm the moly is **350 ppm or more and the pH is between 8.0 and 9.5.**

Maintenance Levels

Test the pH and moly levels after the first three months and every six months thereafter, and after adding water to furnace.

NOTE: If using antifreeze, test the pH and Moly levels once each month. If the bacterial issues occur, the pH will decrease.

NOTE: It should not be necessary to add water to the outdoor furnace more frequently than once every twelve months. If it is more frequent, either there is a leak in the system or the outdoor furnace is boiling because of improper operation or maintenance (see Troubleshooting Section in the Owner's Manual). Be sure to locate and repair the problem immediately. Frequently adding water can cause deterioration in the water jacket. Each time water is added, refer to the instructions provided in the test kit for water testing procedures. If indicated by test results, add MolyArmor 350 as required. Deterioration due to improper operation and/or maintenance is not covered by warranty.

Draining Treated System Water

MolyArmor 350 is composed of common materials. Molybdenum compounds characterized as nontoxic in US Public Health Bulletin 293, by the Federal Hazardous Substances Labeling Act, and by the Occupational Safety and Health Act. However, in keeping with good safety and environmental practices, dispose furnace water in accordance with federal, state and local regulation. Unless regulation prohibits, you may drain the outdoor furnace to a home septic system. If doing so, however, be careful not to overflow the septic system.

Do not drain the outdoor furnace in such a manner that the drain water could in any way contact surface water, stream, river, estuary (where a river meets a sea), lake, pond, ocean or other types of waters.

Do not drain to any location within 50 feet (15 meters) of any water well.

SYSTEM MAINTENANCE

An important part of outdoor furnace maintenance is controlling the quality of the water in the outdoor furnace.

Water Test Kits and Test Results

DATE	pH LEVEL	MOLY LEVEL

Record the results of pH and Moly level tests in the table above. If additional space is needed, record on a separate sheet of paper.

It is very important to keep record of water test results (including the date, pH and Moly level). The pH and Moly test strips and indicator have a shelf life of approximately two years that can affect their accuracy. Test kits should be stored in a dry area at room temperature to obtain maximum accuracy over a longer period of time.

Biological contamination can occur if the furnace is not heated up to 185°F immediately after filling it with inhibitor and water as directed.

NOTE: ANY time water is added to the system, it is extremely important to bring the water temperature up to operating temperature (185°F) as soon as possible, even if it is during the off-season. Failure to bring the water in the system up to operating temperature immediately after filling the system can allow bacteria present in the water to multiply and may increase the potential for corrosion in the system.

If the test indicates a significantly lower-than-recommended pH level (below 8.0), add MolyArmor to increase the pH level.

POST HEATING SEASON MAINTENANCE

The water should be left in the outdoor furnace if the outdoor furnace is not being used for an extended period of time.

1. At the end of the heating season, clean all of the fuel from the hopper. Clean the fuel from the augers by pressing the Auger button until no fuel enters the burn chamber.
2. Remove the aerator and burn chamber; inspect and clean as explained in the Aerator and Burn Chamber section.
3. Clean all the ash out of the outdoor furnace. Scrape the walls and floor of the firebox.
4. Check the chimney box and flues. Clean out any excessive buildup. Any large or dry crusty deposits on the walls or heat exchanger area should be removed. When cleaning the firebox, be sure to wear the appropriate personal protective gear.

⚠ CAUTION

To minimize corrosion caused by accumulated ash, it is especially important to clean the chimney, chimney box and flues at the end of the heating season.

5. When the outdoor furnace is clean, carefully inspect the firebox for any signs of excessive corrosion or deterioration. If any corrosion or deterioration is found, call your dealer. It is always better to do maintenance during the non-heating season.
6. After the inspection is completed, apply a thin coat of new motor oil to the firebox and heat exchanger being sure to work oil into all corners.
7. Inspect the thermal valve as explained in the Thermal Valve section.
8. Place a cover over the chimney to keep rain from entering the outdoor furnace.

Flushing the System

If the system water is brown or orange, it is an indication that the corrosion inhibitor level has not been maintained correctly and corrosion is present in the water jacket. Sludge Conditioner (p/n 166) can be used by circulating the recommended amount through the furnace **for one week** to help clean some of the corrosion from inside the water jacket before flushing, draining and refilling with water and the correct amount of MolyArmor 350.

NOTE: Use one unit of Sludge Conditioner per 200 gallons of system water.

1. De-energize the pump(s) and close the supply and return valves on the outdoor furnace. Remove the inspection panel and insulation covering the drain to gain access to the drain valve. Remove the cap and connect a hose to the drain.
2. Open the drain to drain the system; then flush the water jacket using a wand placed in the vent.

⚠ CAUTION

Completely clean out the firebox before draining water from the outdoor furnace.

3. Close the drain valve securely and replace the cap on drain after flushing the outdoor furnace.
4. Add recommended amount of MolyArmor 350.
5. Fill the outdoor furnace following the procedure in the Fill with Water and Purge Air section. Start the pump(s) and bring the water temperature up to operating temperature (185°F) for 24 hours with the system circulating to thoroughly mix the MolyArmor 350.

NOTE: ANY time water is added to the system, it is extremely important to bring the water temperature up to operating temperature (185°F) as soon as possible, even if it is during the off-season. Failure to bring the water in the system up to operating temperature immediately after filling the system can allow bacteria present in the water to multiply, which may increase the potential for corrosion in the system.

6. Insulate the area using a mat of fiberglass insulation.
7. Install the inspection panel and secure with self-tapping screws.

Adding Antifreeze to Outdoor Furnace System

If using other antifreeze, use ONLY uninhibited, undyed, “raw” propylene glycol industrial grade with softened water and add the correct amount of MolyArmor 350 to achieve 350 ppm moly and 8.0 to 9.5 pH levels. Some distributors call this type of antifreeze PGI (shorthand for Propylene Glycol Industrial grade).

Most outdoor furnaces are installed **without** antifreeze when an existing heating system is in place and there is no anticipation of leaving the outdoor furnace unattended for extended periods of time (10 days or more). If the building being heated has an alternate heat source, system water may be kept from freezing by running the circulating pump(s) and drawing heat from the existing furnace or boiler in the home or building.

To prevent freezing if the outdoor furnace is not fired for extended time periods or if lengthy power outages are anticipated during cold weather, a nontoxic propylene glycol may be used in the system. Some types of antifreeze that contain various inhibitors have been known to create problems like coagulation and jelling. To prevent potential problems, **do not use propylene glycol that is premixed with inhibitors.** MolyArmor 350 is compatible with (raw) propylene glycol. It is important to use MolyArmor 350 with straight propylene glycol for corrosion protection. If adding antifreeze to the system, it is imperative that the entire system contain **at least 30% antifreeze concentration mixed with water that is 6.5 to 8.0 pH. Softened water is recommended, if available. Do not use reverse osmosis or deionized water that has very low pH.** Bacterial growth is likely to occur with low antifreeze concentrations and can cause corrosion in the furnace water jacket and/or clogging of heat exchangers. To confirm the antifreeze solution is adequate and to kill bacteria, immediately heat the system up to 185° F, allow the pumps to circulate for at least 24 hours and then obtain a sample of the system water. Using an antifreeze tester, the solution must be protected to 10°F (-12°C) or below.

NOTE: If using antifreeze, test the pH and Moly levels once each month. If the bacterial issues occur, the pH will decrease.

NOTE: Be sure to adhere to all warnings and precautions on the antifreeze label.

NOTE: Do not use automotive or RV types of antifreeze.

Fuel Selection

Before You Start Operating Your Maxim Outdoor Pellet Furnace

Be sure to read carefully and observe all of the information in the entire Owner's Manual.

If any questions arise that cannot be answered by the information in this manual, be sure to contact your dealer.

Use only premium quality wood pellets.

Feed rates and safe operation are not warranted with alternative fuels.

⚠ CAUTION

Do not use materials that will clog or jam the auger delivery system or damage the furnace. The heat exchanger must be cleaned regularly to maintain proper combustion air flow.

Fuel Quality and Storage

Fuel must be stored in a container or building that prevents rain or other moisture from contact with the fuel.

⚠ WARNING

Do not store fuel within the outdoor furnace installation clearances or within the spaces required for fueling, ash removal and other routine maintenance operations.

⚠ CAUTION

If fans are used in the fuel storage area, they should be installed so as not to create negative pressures in the non-habitable building where the outdoor furnace is located.

Other Important Information About Fuels

⚠ CAUTION

Do not burn plastic, garbage, treated wood or fuels not listed for this outdoor furnace.

NOTE: Chloride or sulfurous gases will generate if plastic or rubber is burned and will mix with the moisture from the wood pellets to form hydrochloric or sulfuric acids in the firebox, creating corrosion.

NOTE: Wood pellets with a high sawdust content may cause a feed rate interruption. An interruption in fuel flow may result in an empty burn chamber, or if the blockage frees itself after the fire has gone out, a burn chamber full of unburned fuel.

Operating Instructions

Filling the Hopper

Open the hopper lid and add fuel. After filling, make sure the hopper lid is securely closed to prevent moisture from entering the hopper. Do not over-fill the hopper.

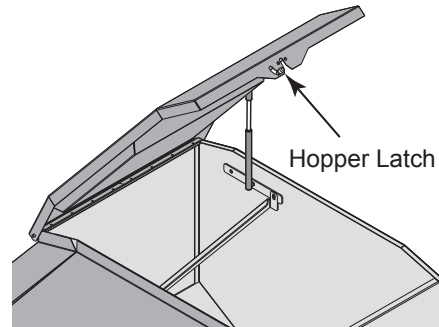

NOTE: The hopper lid may be locked to prevent unauthorized access.

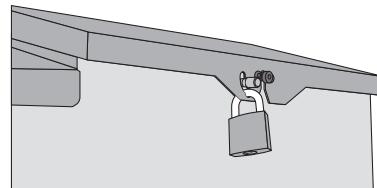

Power Up

Press the Power button to turn the FireStar controller on.

Basic Operation

The FireStar automatically controls combustion to allow the furnace to operate properly in most installations without adjustment.

Lighting Instructions

Ignition is automatic. The fan will start and the ignitor will operate until the fuel in the burn chamber is lit.

Auger Prime

If the hopper and auger are empty and fuel has been added, to expedite delivery of fuel to the burn chamber, start a prime cycle by pressing the Auger button. The prime cycle timer will count down. When starting from an empty auger, it may take two prime cycles. During the timer count down, prime can be stopped by pressing the Auger button again.

Relighting after a Fire Out

If the hopper runs out of fuel (causing a Fire Out alarm on the controller), press and hold the Reset button to restart the ignition sequence (after filling the hopper with fuel).

NOTE: Fuel must be flowing from the transfer auger to the burner auger when the burner auger is turning.

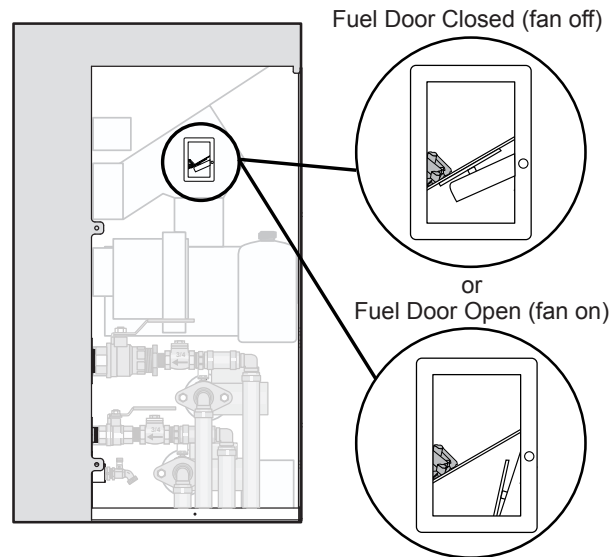

NOTE: Fuel must not build up so that it prevents the fuel door from closing as shown. This is an indication the burner auger is obstructed or has quit turning. If this condition exists, inspect the burner auger and clean or replace as necessary. If condition persists contact your WoodMaster dealer for more information.

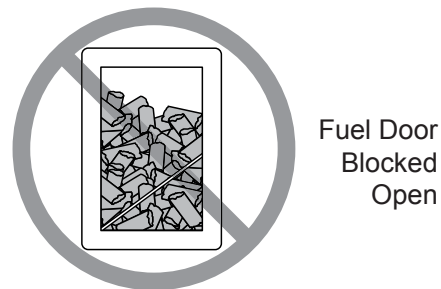

FireStar Controller

Settings on the combustion controller can be adjusted to optimize the performance of the Maxim for a variety of different conditions. See the FireStar Operation Manual for instructions on changing the controller and for more information.

Operating Precautions

NOTE: If the controller is flashing  the system senses a low water condition. This outdoor furnace is equipped with an automatic shut down system if the water level falls to an unsafe level. The water level in the outdoor furnace is safe when the water level indicator rod is above the vent cap.

1. Do not burn garbage, gasoline, rubber, engine oil, naphtha, plastics, treated wood, cord wood or combustibles other than the fuel specified.
2. Do not store combustibles within the installation clearances listed on the Important Precautionary Information page. Be sure to leave a safe amount of room for cleaning out ash without causing a fire hazard. **Keep the area around the outdoor furnace clear of combustible materials. Combustible debris may be easily ignited if embers spill out of the firebox.**
3. The outdoor furnace water jacket must not be allowed to pressurize. Inspect the vent cap periodically for any obstructions or restrictions. The vent cap must fit loosely over the vent. Do not extend or connect anything to the vent pipe.



4. All cover plates, enclosures and guards must be secured at all times except during maintenance, inspection, and servicing.
5. In case of a power outage, a small generator can provide enough electricity to operate the system.
6. If any questions should arise that cannot be answered by the information in this manual, be sure to contact either your dealer or qualified installer.

Smoke in Hopper

How air flows through the furnace is an important part of optimal operation. Smoke in the hopper is an indication that the air flow through the furnace is restricted, obstructed or different than it should be.

⚠ CAUTION

Operating for extended periods of time with air flow through the furnace restricted (i.e., smoke in the hopper) can damage components in the furnace.

If smoke in the hopper occurs, check the following:

Heat exchanger obstructed - clean the heat exchanger.

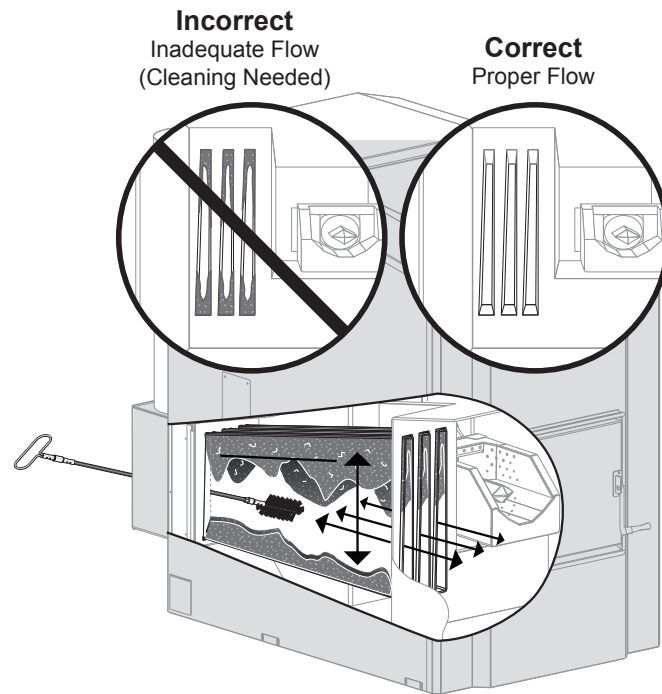

Aerator covered by ash - do not allow ash in the burn chamber to accumulate over the aerator. Use the cleaning rod to pull ash forward to ash collection area.

Carbon buildup - inspect the burner auger where it enters the firebox for carbon buildup and clean if necessary.

Chimney is obstructed - inspect the chimney and chimney connector and clean if dirty or obstructed. If a spark arrester is installed, ensure it is not dirty or obstructed.

Chimney too short - may need to increase the height of the chimney.

Routine Maintenance

⚠ CAUTION

Use only genuine WoodMaster Parts and Accessories if it ever becomes necessary to replace any component of the outdoor furnace.

Routine inspections and maintenance are essential to the proper operation and longevity of the outdoor furnace. The items indicated in the preventive maintenance schedule are intended to serve as a guideline. Actual intervals between inspections and maintenance may vary depending on a number of factors, including your heat load requirements, type of fuel used and outdoor temperatures.

PREVENTIVE MAINTENANCE SCHEDULE	SERVICE INTERVAL						SEE SECTION	
	Before first operation	Daily	Weekly	Monthly	Semi-Annually	Post-Season		
OPERATION								
Check water level.	●	●						1
Remove ash and hard deposits (clinkers).		[G]	[C]				●	2
Inspect firebox and firebox ash area.	●			[B]			●	3
Inspect gaskets.	●					●		4
Inspect and clean heat exchanger, chimney transition.			[C]				●	5
Inspect and clean aerator and burn chamber.		[A]						6
Lubricate door and hopper lid hinge points.							●	7
Check thermal valve.				[B]				9
Test thermal valve.	●						●	10
Check pH and moly levels of water.	●					[D]	●	[E]
Check that the outdoor furnace is level.						●		[F]
Check fuel door operation.			●					8

- [A] When the outdoor furnace is new, daily for the first week.
- [B] When new, after one month, then midway through the heating season and in the spring.
- [C] Weekly until interval for your application can be determined.
- [D] When new, after three months, then every six months thereafter.
- [E] Refer to **Testing Treated Water in the Outdoor Furnace**.
- [F] Refer to **Leveling the Outdoor Furnace**.
- [G] During the first few weeks of operation, or when switching to a new brand of wood pellets, check ash level daily to determine rate of accumulation.

Maintenance Sections

Refer to the Preventive Maintenance Schedule for the recommended intervals with which to perform these maintenance items.

Section 1 - Water Level

The water level in the outdoor furnace is safe when the water level indicator rod is above the vent cap. If adding water is necessary, refer to the Water Quality and Maintenance section.

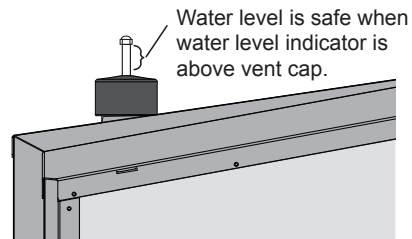

Section 2 - Ash Removal

An ash scoop is included with your outdoor furnace. For your protection, always wear the appropriate personal protective gear when cleaning ash from the firebox.

⚠ CAUTION

Always wear the appropriate personal protective gear when cleaning ash from the firebox.

⚠ CAUTION

When cleaning the outdoor furnace, be careful not to spill any hot ash outside of the noncombustible container.

1. Do not allow ash in the burn chamber to accumulate over the aerator as shown. Use the cleaning rod provided to pull the ash forward to the ash collection area.

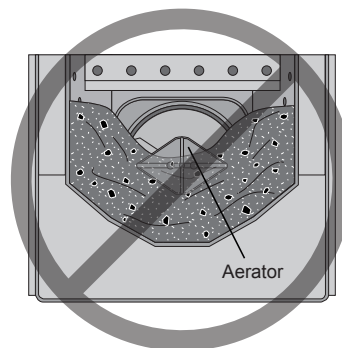

Use scraping tool to remove any crusty deposits or clinkers from corners and under the ignitors.

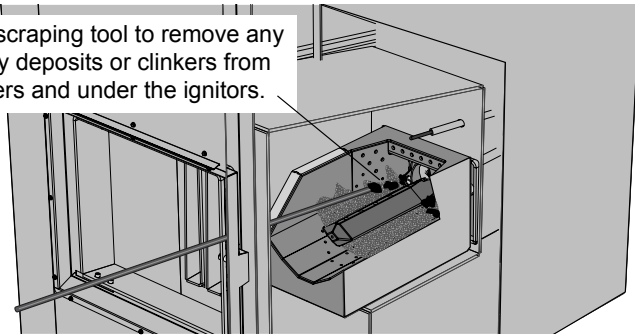

2. It is important to remove the ash in the firebox before it solidifies to prevent sealing in moisture on the bottom and along the edges. It is especially important to scrape all of the firebox where build up and ash are collected. Any heavy or solidified ash should be removed.

NOTE: If these maintenance operations are not performed as directed, deterioration can result from the moisture trapped between the ash and the steel.

3. If burning wood pellets with a high ash content (or corn), hard deposits may form in the burn chamber. Remove the deposits by scraping the burn chamber with the cleaning rod provided.
4. **Disposal of ash** - Place ash in a metal container with a tight-fitting lid. Store the closed container of ash on a noncombustible surface, well away from all combustible materials until ready for final disposal. Do not dispose (either by burying or other means) until all cinders have thoroughly cooled.
5. Each time the ash are cleaned out, inspect the outdoor furnace door rope gasket to make sure it is sealing properly.

Section 3 - Firebox

NOTE: Proper firebox maintenance is essential to the longevity of the outdoor furnace.

Remove ash as described in the Ash Removal section. Scrape all surfaces in the firebox, paying close attention to the corners. If needed, the aerator and burn chamber can be removed for a more thorough cleaning (see Aerator and Burn Chamber).

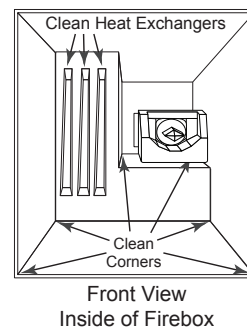

Section 4 - Gaskets

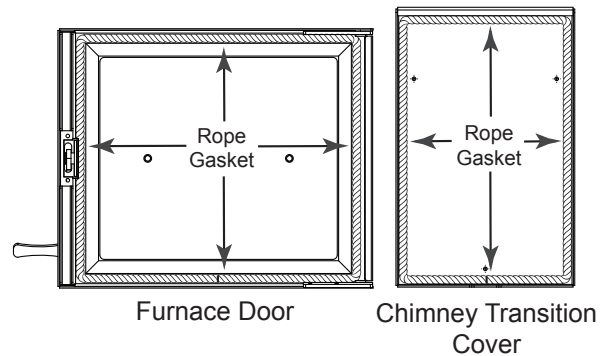

Inspect the rope gasket on the furnace door and on the chimney transition cover at the back of the furnace. A uniform indentation in the rope indicates the rope gasket is sealing properly. If it is not sealing properly, or if the rope gasket is damaged, replace the rope gasket.

Using the figure as a reference, inspect the hopper lid gasket and replace if necessary.

NOTE: Replacement gaskets for the furnace door, chimney transition cover and hopper are available from authorized WoodMaster dealers.

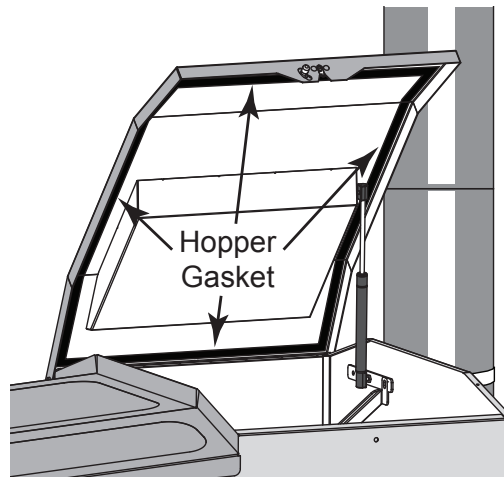

Section 5 - Heat Exchangers and Chimney Transition

The heat exchangers should be cleaned every time ash is removed, or if air flow through the heat exchangers becomes restricted.

To inspect the heat exchangers, **remove the chimney transition cover** on the back of the furnace and open the firebox door. It will probably be necessary to kneel down at the back of the furnace to look through each heat exchanger passageway. The heat exchangers taper up from the back of the furnace to the front. Pay particular attention to the top of each passageway as this is where ash tends to accumulate. The top of each heat exchanger passageway is where most air flow and heat transfer occur, so it is especially important to keep the top free of any buildup.

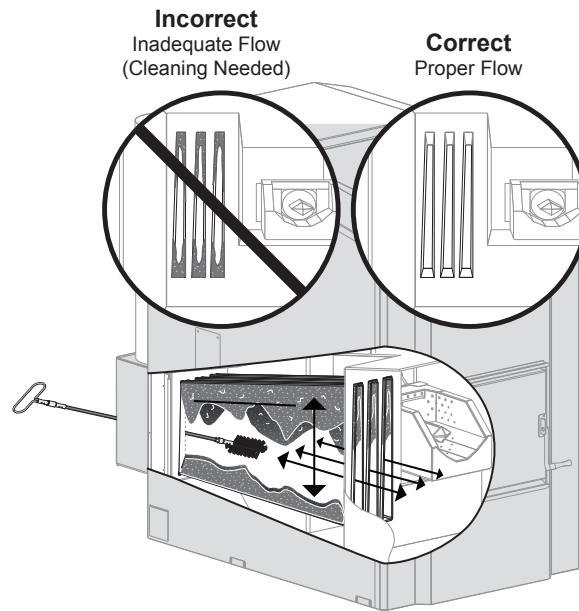

Remove deposits by scraping with the cleaning brush provided with your outdoor furnace. Use the cleaning brush from the back of the furnace, working from top to bottom, and from back to front in each passageway in the heat exchanger.

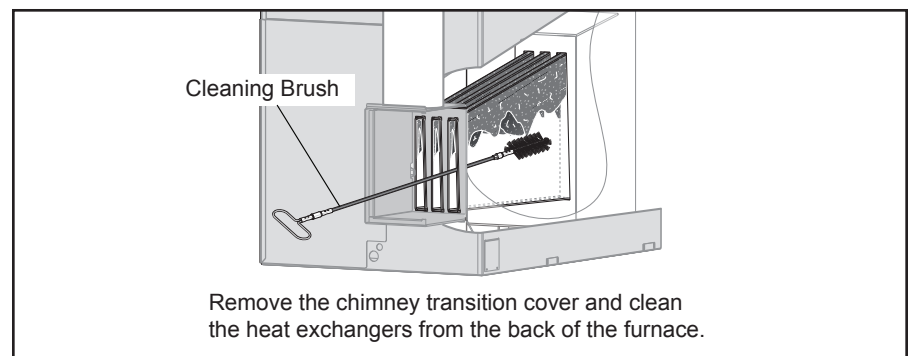

Inspect the chimney transition and clean if an excessive amount of buildup is present.

NOTE: Twice a month during the heating season, inspect the chimney transition for excessive buildup. If present, the buildup should be removed for proper operation and fire safety. In case of a chimney fire, close the firebox door.

Check the integrity of the chimney transition attachment bolts as they support the weight of the chimney.

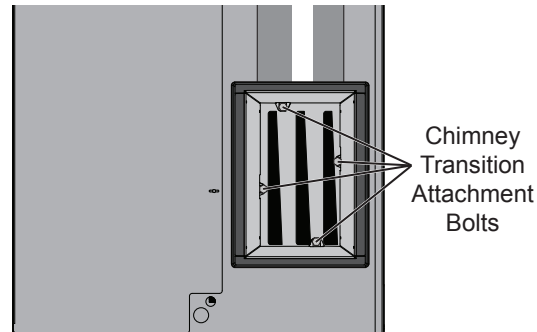

Section 6 - Aerator and Burn Chamber

As the quality of wood pellets varies from region to region, so will the requirements for component maintenance. The aerator and burn chamber should be inspected on a regular basis to ensure mineral deposits do not hinder burner performance. Regular inspection and removal of any deposits will ensure best furnace operation.

NOTE: Make it a habit to visually inspect the burner on a weekly basis during the heating season.

Maxim M255 PE models

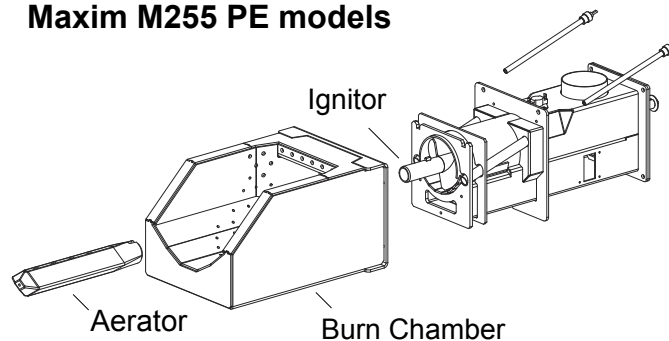

⚠ CAUTION

Before performing any maintenance on the burn chamber or aerator, shut off the burner, allow the outdoor furnace to cool and clean the firebox.

Disassembly

1. Turn the aerator $1/4$ turn counterclockwise and pull straight forward to remove.
2. Remove the side access panel from the furnace. Roll back the insulating tape securing the thermocouple and remove the thermocouple.
3. Open the firebox door. Using the illustration as a reference, place a $3/4$ " thick, 4-ft long board under the front of the burn chamber. Use the board to pry up the front of the burn chamber; then push the board in until it reaches the back of the firebox. Pry up the entire burn chamber to disengage the hooks on the back of the burn chamber. Remove the board with burn chamber through the door.

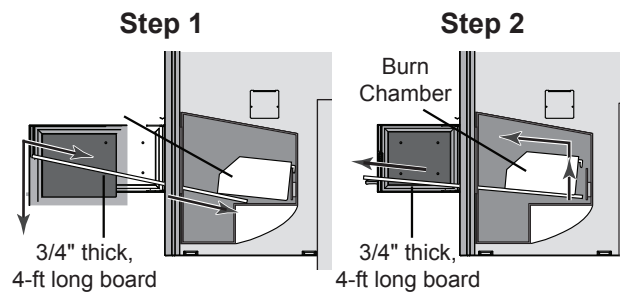

NOTE: It will be necessary to angle the burn chamber when removing it through the firebox opening.

Inspecting and Cleaning

1. Inspect the aerator and burn chamber for any build-up of mineral deposits, especially in and around the combustion air holes.
2. To clean combustion air holes, use a suitably sized drill bit, round wire brush or other suitable tool to remove any deposits. Be careful not to damage, deform or increase the size of the combustion air holes. Clean ash from inside the burn chamber.
3. Scrape carbon deposits from the auger, the surfaces of the aerator and the burn chamber.

⚠ CAUTION

Do not strike the aerator or burn chamber with a hammer or other hard item to remove deposits. Doing so could damage the parts and prevent proper operation of the burner.

⚠ CAUTION

Before placing the aerator in water, allow it to cool thoroughly. Do not put the aerator in snow to cool faster as the aerator can be damaged.

Assembly

1. Inspect the burn chamber gasket for damage and replace if necessary. Place the 3/4" thick, 4-ft long board used to remove the burn chamber in the firebox opening; then place the burn chamber on top of the board.

NOTE: It will be necessary to angle the burn chamber to install it through the firebox opening.

2. Push the board and burn chamber to the back of the firebox; then use the board to lift the burn chamber up so the hooks on the back of the burn chamber can engage. Remove the board.
3. Place the aerator on the end of the auger tube; then rotate it 1/4 turn clockwise to lock it in position.
4. Install the thermocouple and replace the insulating tape. Install the side access panel on the back of the outdoor furnace.

Section 7 - Door and Hopper

Lubricate the door pivot points and hopper lid latch with a light petroleum distillate (WD-40 or equivalent).

Section 8 - Check Fuel Door Operation

Make sure the fuel door is open when the combustion fan is running and closed when the fan is stopped. It is important to check the fuel door monthly to make sure it is operating properly. When operating properly, the fuel door will be closed when the combustion fan is not operating.

Section 9 - Thermal Valve

The thermal valve does not require electricity to operate. If during a power outage, a high temperature condition is detected in the burner auger area, the thermal valve is designed to release a small amount of water into the burner auger area to cool the area.

Twice each heating season, check to see if the thermal valve has activated:

1. Disconnect the electrical power at the main power source.
2. Remove the access panels from the back corner of the furnace and set aside.
3. Remove the 1/2" silicone tubing from the thermal valve, leaving it attached to the discharge tube. Blow air through the tubing to clean. Connect the silicone tubing to the thermal valve making sure not to kink the silicone tubing.

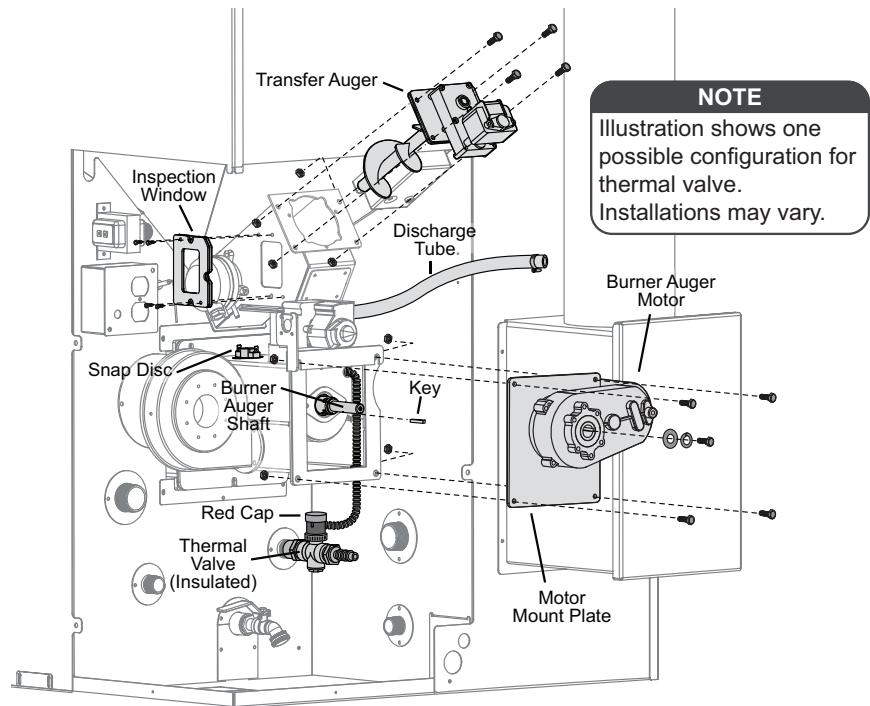

NOTE: The illustration shows one possible configuration for a thermal valve. Installations may vary slightly.

4. Install the access panels.
5. Connect the electrical power at the main power source.

⚠ CAUTION

Do NOT operate this appliance with any panels removed.

IF THE THERMAL VALVE ACTIVATES

If the thermal valve activates, it will be necessary to clean out the areas in which water from the thermal valve may have come in contact with the wood pellets. Do not use the furnace until these areas have been thoroughly cleaned. Read and understand these instructions before beginning the procedure.

NOTE: The previous illustration shows the disassembly required to clean the furnace if the thermal valve activates.

1. Disconnect the electrical power at the main power source.
2. Remove the access panels from the back corner of the furnace and set aside.
3. Open the hopper lid and empty the hopper. One option for emptying the hopper is to use a wet-dry shop vacuum to remove the unused wood pellets. Wood pellets at the bottom of the hopper may have been saturated with water causing them to expand and fill the opening. If it is necessary to use a tool to break up the expanded wood pellets, use extreme caution not to damage any components of the furnace.

Remove Transfer Auger

1. Disconnect the wires from the transfer auger motor.
2. Remove the bolts securing the transfer auger motor mount plate to transfer auger housing; then remove the transfer auger assembly.

NOTE: Do not pull straight out or force the transfer auger assembly while removing. Turn the assembly counterclockwise.

3. Remove the screws securing the inspection window to the side of the hopper; then remove the inspection window.
4. Remove the 1/2" silicone tubing from the thermal valve, leaving it attached to the discharge tube. Blow air through the tubing to clean.

Remove Aerator, Burner Auger and Burner Auger Motor

1. Inside the firebox, turn the aerator 1/4 turn counterclockwise and pull straight forward to remove.
2. Disconnect the burner auger motor wiring connector.
3. Remove the bolt and washer securing the burner auger to the burner motor. Set the bolt and washer aside for assembly.
4. Remove the four bolts securing the motor mount plate to the transition box; then remove the burner auger motor and motor mount plate.
5. Remove the key from the keyway slot on the auger shaft and set aside for assembly.
6. Using a wooden block, tap the burner auger into the firebox. Do not hit the bushing.
7. Remove the burner auger from inside the firebox.

Clean the Affected Areas

1. Inspect the bottom of the hopper and remove any wet fuel from the opening at the bottom.
2. Using a wet-dry shop vacuum, clean the transfer auger tube and the drop tube of any unused fuel or wet fuel; then clean the transition box that houses the burner assembly.

NOTE: Make sure that no fuel gets pushed back toward the combustion fan area or the combustion fan could be damaged.

3. Make sure the flightings on the augers are clean and dry.

Replace Snap Disc

1. Disconnect the two wires from the snap disc located on top of the transition box.
2. Remove the two screws securing the snap disc to the transition box; then remove the snap disc.
3. Place a new snap disc into place and secure with screws; then connect the two wires.

Install Burner Auger, Burner Auger Motor and Aerator

1. Apply grease to the portion of the burner auger shaft that will be seated in the bushing; then, from inside the firebox, install the burner auger into the burner assembly making sure it is properly aligned and seated in the bushing.
2. Install the motor mount plate on the transition box. Tighten the screws hand-tight only.
3. Align the keyway slot on the auger shaft with the keyway slot in the burner motor; then tap the key into the slot. Secure the burner auger with the bolt and washer removed earlier. Tighten securely.
4. Using a flashlight inside the firebox, check that the auger flightings are centered in the burner tube. If necessary, loosen the motor mount plate bolts and move the motor mount plate to center the auger flightings in the burner tube. Tighten the motor mount plate bolts securely.

Install Transfer Auger

1. Install the transfer auger assembly in the transfer auger housing. Make sure the end of the transfer auger tube fits over the brass guide in the transfer auger housing. Verify by visually checking from the top of the hopper. Secure with the bolts.

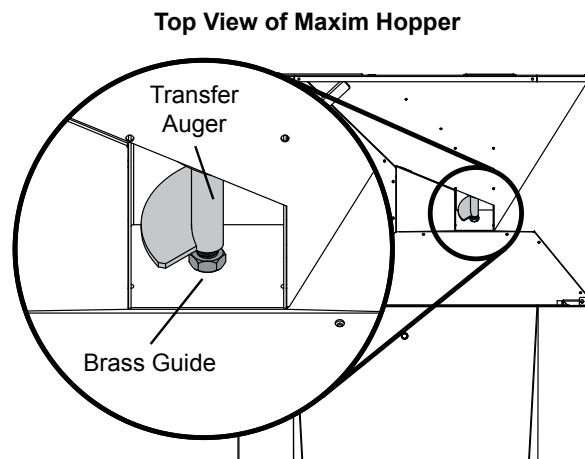

2. Connect the wires to the transfer auger motor.

Finish Installation

1. Install the inspection window and secure with the screws.
2. Attach the 1/2" silicone tubing to the thermal valve and secure with hose clamp.
3. Install the access panels.
4. Connect the electrical power at the main power source.
5. Before adding fuel to the hopper, start the furnace and verify that both augers are turning freely without binding. The transfer auger can be viewed from the hopper and the burner auger can be viewed using a flashlight from inside the firebox.
6. Once it has been determined the augers are turning freely, add fuel to the hopper and start the furnace following the procedure in Initial Start-up.

Section 10 - Test Thermal Valve

Twice each heating season (at the beginning and the end), check to make sure the thermal valve operates properly.

⚠ WARNING

Allow the outdoor furnace to thoroughly cool down before performing maintenance.

1. Disconnect the electrical power at the main power source.
2. Remove the access panels from the back corner of the furnace and set aside.
3. Remove the 1/2" silicone tubing from the thermal valve; then place a small cup under the outlet on the valve.
4. Push down on the red cap of the thermal valve and run a small amount of water through the valve to make sure it is operating properly.
5. Connect the silicone tubing to the thermal valve making sure not to kink the silicone tubing.
6. Install the access panels.
7. Connect the electrical power to the main power source.

TROUBLESHOOTING

A. FURNACE DOES NOT HEAT (BUILDING IS LOSING TEMPERATURE)

1. **Out of fuel** - Check firebox to see if fire is out. Add fuel as necessary.
2. **Fire out** - If the controller is flashing **FD** refer to FireStar Controller for Maxim Operating Instructions.
3. **Thermal valve opened** - If during a power outage, a high temperature situation is detected in the burner auger area, the thermal valve will open to release a small amount of water into the burner auger area to cool the area. To determine if this has happened, first look in the firebox for the presence of water. Also check the glass inspection port just above the burner auger. If the fuel appears to have expanded from absorbing water, the thermal valve has opened. Contact your WoodMaster dealer for assistance.
4. **Circulation valve(s) closed** - Be sure all valves in the system are open.
5. **Circuit breaker off** - Reset the circuit breaker that supplies power to the outdoor furnace.
6. **Circulation pump(s) not operating** - Disconnect power to the pump. Close valves at the pump. Disassemble the pump and try to turn the pump shaft. If the shaft is stuck, replace the pump cartridge. Replace only the cartridge whenever possible. If necessary, replace the pump. Follow instructions supplied with the pump.
7. **Air in system** - Check for air in the supply and return lines or heat exchangers. If you hear a gurgling sound in a heat exchanger, air is present in the system. Shut off the pump, wait 15 seconds and start the pump. If it is necessary to force air from lines, refer to Section 7.
8. **Outdoor furnace exhaust obstructed** - Check outdoor furnace exhaust for obstructions by removing the chimney transition cover to expose the heat exchanger. The heat exchanger can also be observed from the front of the furnace through the front door opening.
9. **Combustion fan blocked or obstructed** - Check the combustion fan for obstructions.
10. **Building(s) poorly insulated or uninsulated** - Poorly insulated or uninsulated buildings and/or buildings with uninsulated or poorly insulated ceilings can cause excessive fuel consumption and or heating problems.
11. **Supply and return lines installed incorrectly** - Make sure the hot supply water line is connected to the correct fitting on the outdoor furnace and heat exchanger.
12. **Circulation pump(s) installed incorrectly** - Circulation pump(s) must be installed in the supply line(s) with the arrow on each pump pointed away from the outdoor furnace. Remove the pump and install correctly. Refer to the System Installation section for installation guidelines.
13. **Underground supply and return lines insulated poorly** - Heat loss from poorly insulated underground supply and return lines is often indicated by an unusually high amount of snow melting above the lines when the ground temperature is 10°F (-12°C) or colder.
14. **Supply and return lines uninsulated** - Uninsulated supply and return lines in areas that are not intended to be heated (unheated crawl spaces, under mobile homes, etc.) may cause excessive heat loss. Insulate the supply and return lines.
15. **Low water** - If the controller is flashing **LD** the system senses a low water condition. Check water level and if necessary add water according to the Water Quality and Maintenance section. If adding water does not correct the problem, contact your WoodMaster dealer.

- Poor water quality** - Water with high amounts of solids, sand or dirt can create deposits inside the wall of heat exchanger components, reducing the amount of heat output. If this condition is suspected, contact your WoodMaster dealer.

B. FURNACE IS OVERHEATING (FIRESTAR LED DISPLAYS **HI**)

- FireStar controller set incorrectly** - Lower the water temperature setpoint and/or adjust the heat output settings in one or all of the three modes (see Setting the FireStar Controller for Heat Load and Efficiency).
- High limit switch tripped** - Lower the water temperature setpoint and/or adjust the heat output settings in one or all of the three modes (see Setting the FireStar Controller for Heat Load and Efficiency).
- Water is not circulating** - The pump should run and water should circulate continuously through the supply and return lines to keep water temperature uniform in the outdoor furnace.
- Circulation valve(s) closed** - Be sure the proper valves in the system are open to allow circulation.

C. BACK BURN (FIRESTAR DISPLAYS **b b**)

- High temperature in burner auger area** - Everything but the burner auger will be disabled. The burner auger will run for two minutes, pause for 10 minutes, and continue as required. The Back Burn alarm will not stop until the controller detects that the temperature in the burner auger area has dropped.

D. FREQUENT PUMP TROUBLE OR POOR WATER CIRCULATION

- Pump mounted incorrectly** - The pump must be mounted with the pump motor horizontal and the junction box either on the side or on top.

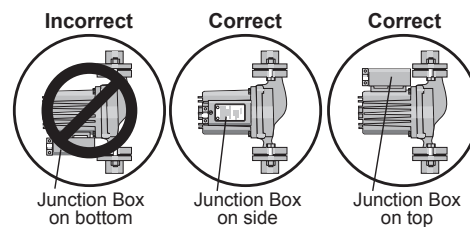

- Deposits in water lines/heat exchanger walls** - If water high in silica or other mineral content has been used to fill the outdoor furnace, material deposits may build up on the insides of the supply and return lines and on the heat exchanger walls. If this occurs, the system will need to be drained and then cleaned using Sludge Conditioner (p/n 166). The system must then be refilled with the proper amount of MolyArmor 350 and good quality water (softened water, if possible).
- Water will not circulate** - If the system has been drained and refilled, or if the system has been opened for any reason (e.g., replacement of pump, adding heat exchangers, repairing a leak), air must be purged from the system (see Filling System with Water and Purging Air section).
- Poor water quality** - Water with high amounts of solids, sand or dirt can cause frequent pump failure. Use softened and/or filtered water.

E. BURNING AN EXCESSIVE AMOUNT OF FUEL.

1. **High volume water heating** - High volume water heating (e.g., car wash, swimming pool, etc.) will require high fuel consumption.
2. **Excessive heat loss** - See items 8-12 of Furnace Does Not Heat.
3. **Supply and return line heat loss** - If not using ThermoPEX, supply and return lines buried in a wet, low-lying area may cause a large heat loss that will greatly increase the fuel consumption.
4. **High heat demand** - Concrete slabs (with radiant heat) that are poorly insulated or are exposed to water or cold outside temperatures will require increased fuel consumption. Bringing a concrete slab up to temperature the first time will take a considerable amount of time and fuel; once warm, fuel consumption will be reduced if the concrete slab and building are insulated properly. The following items will cause a high heat demand: poor insulation, large amounts of glass windows/doors (e.g., greenhouses), overhead doors, uninsulated crawl spaces, outdoor air infiltration and air leaking through foundation.

F. FUEL NOT BURNING PROPERLY

1. **Poor fuel or out of fuel** - See Fuel Quality and Storage section for recommendations about fuel types. Check firebox to see if fire is out. Add fuel as necessary.
2. **Combustion fan blocked or obstructed** - Check the combustion fan and air flow path for obstructions.
3. **Outdoor furnace exhaust obstructed** - Check outdoor furnace exhaust for obstructions. To inspect the heat exchangers, remove the chimney transition cover on the back of the furnace and open the firebox door. It will probably be necessary to kneel down at the back of the furnace to look through each heat exchanger passageway.

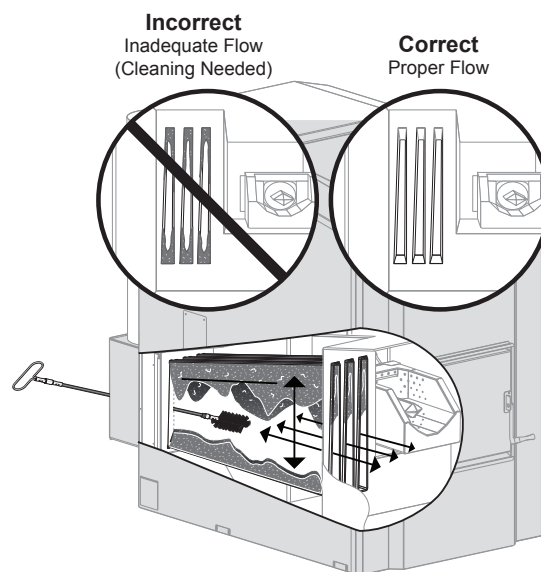

4. **Heat output set too high or too low** - For best results, determine the lowest water temperature setpoint the outdoor furnace can be set to that will supply enough heat to the heat emitters. See FireStar Controller Manual for more information.
5. **Air setting too high or too low** - See Setting the FireStar Controller for Heat

G. BURNER AUGER MOTOR NOT TURNING

1. **Fuel wet or swollen** - Check to see if the fuel has absorbed moisture and is swollen in the burner auger area. If the thermal valve has activated, it will be necessary to remove all of the fuel from the hopper; then remove the transfer auger, aerator, burner auger and burner auger motor and clean the entire area.
2. **Burn chamber obstructed** - Clean the burn chamber especially at the end of the auger.
3. **Motor overheated** - Clean the burner auger and allow the burner auger motor to cool.

H. IF CORROSION IS PRESENT

Corrosion in the firebox can occur when the outdoor furnace is being operated improperly. To maximize the life of your investment, it is important to identify signs of corrosion early (you can do this by performing the items in the Preventive Maintenance Schedule) and take measures to correct it as soon as possible. Some, but not all, causes of corrosion are listed below with possible solutions. If you are unsure how to proceed, contact your WoodMaster dealer.

1. **Water temperature is too low** - If the heat load in the system is too large, the water in the system will not reach high enough temperatures and corrosion can occur. Re-evaluate the system and match heat load to the outdoor furnace.

NOTE: To reduce condensation in the firebox, set the temperature to 185°F or higher.

2. **Heat load is too high** - Reduce heat load.
3. **Thermostatic valve is not installed** - A thermostatic valve must be installed on each set of supply and return lines in the system to maintain the outdoor furnace water temperature above 150°F (65°C).
4. **Firebox wasn't cleaned out at the end of the heating season** - Be sure to follow the post-heating season maintenance schedule which includes scraping out firebox and removing all ash.

I. WATER TEMPERATURE AT SUPPLY PORT LOWER THAN THE FIRESTAR INDICATES

1. **Water flow too low** - Add wraparound pump if using one set of lines. Install higher pressure-volume pumps if using two sets of lines.

J. LOW WATER (FIRESTAR LED DISPLAYS)

System leak - Try to identify the leak by inspecting all lines, fittings, heat exchangers, etc. in the system and repair as needed. If the leak cannot be found and **if there is no chance of the system or furnace freezing**, the following procedures can help determine whether the leak is in the furnace or somewhere else in the system:

- a. Turn off the FireStar controller; then completely empty the firebox of all coals, embers and ash.
- b. Allow the furnace to cool below 100°F (38°C).
- c. Refill the outdoor furnace with water until the water level indicator rod is above the vent cap. Add MolyArmor 350 if needed.
- d. Record the water level by measuring how far the water level indicator rod is above the vent cap.
- e. Close all shut-off valves on the hot supply and return lines at the outdoor furnace.
- f. Check the water level periodically during the next 48 hours (the water level may drop slightly as the water cools).

- g. Inspect the firebox and under and around the outside of the outdoor furnace for evidence of a leak each time the water level is checked.

During the 48-hour inspection period, the water lines should also be checked for leaks using a pressure gauge and the following procedure:

- a. Isolate the furnace by closing all shut-off valves on the hot supply and return lines at the furnace.

⚠ WARNING

Be sure to close all shut-off valves on the hot supply and return lines at the furnace. DO NOT ALLOW THE FURNACE TO PRESSURIZE.

- b. Isolate each zone in the system using shut-off valves.
- c. Pressurize each zone with domestic water or air; then check the pressure gauge after 12 hours. A drop in pressure indicates that a leak is present in the zone. Before resuming furnace operation, it will be necessary to repair the leak.

L. SMOKE IN THE HOPPER

How air flows through the furnace is an important part of optimal operation. Smoke in the hopper is an indication that the air flow through the furnace is restricted, obstructed or different than it should be.

⚠ CAUTION

Operating for extended periods of time with air flow through the furnace restricted (i.e., smoke in the hopper) can damage components in the furnace.

1. **Heat exchanger dirty or obstructed** - Because the gases moving through the heat exchanger are hot, most of the heat transfer occurs at the top of the heat exchangers. It is therefore important to ensure that the top of each heat exchanger passageway is clean and not obstructed or blocked from ash. Use the procedure from 9.5 Heat Exchanger in the Routine Maintenance section to inspect the heat exchanger for obstructions or restrictions and clean if necessary.
2. **Aerator covered by ash** - do not allow ash in the burn chamber to accumulate over the aerator. Use the cleaning rod to pull ash forward to ash collection area.
3. **Carbon buildup** - inspect the burner auger where it enters the firebox for carbon buildup and clean if necessary.
4. **Fan setting for HIGH mode set too high** - Decrease the fan setting for HIGH mode (see Setting the FireStar Controller for Heat Load and Efficiency).
5. **Chimney dirty or obstructed** - Inspect the chimney transition and chimney for obstructions or restrictions and clean if necessary.
6. **Spark arrestor (if present) dirty or obstructed** - Inspect the spark arrestor screen for obstructions and remove. Clean the spark arrestor if it is restricting air flow.
7. **Chimney not drafting properly** - Proper draft is necessary for the Maxim to operate optimally. Draft occurs when the temperature in the chimney is high enough to cause a negative pressure that "pulls" the exhaust up through the heat exchanger and out the chimney.

If poor draft is suspected, check that the chimney transition cover is properly sealing. Adding chimney sections may be required. However, due to a number of variables (e.g., objects like buildings and trees in close proximity, nearby terrain such as hills, valleys, etc.), poor draft can be an intermittent problem.

L. SMOKE IN THE HOPPER

1. **Outdoor furnace not level** - The furnace should be leveled so that the back of the transition box (i.e., the burner auger motor end) is slightly higher than the front. If the burner auger is not sloped down toward the front of the furnace, condensation can form in the burner auger tube and drip into the transition box. See Leveling the Outdoor Furnace section.
2. **Ash covering aerator** - Do not allow ash in the burn chamber to accumulate over the aerator.

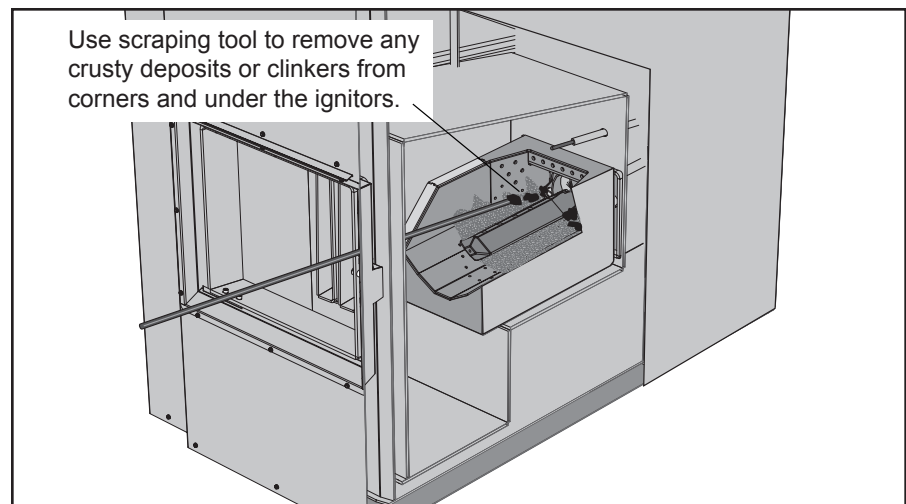
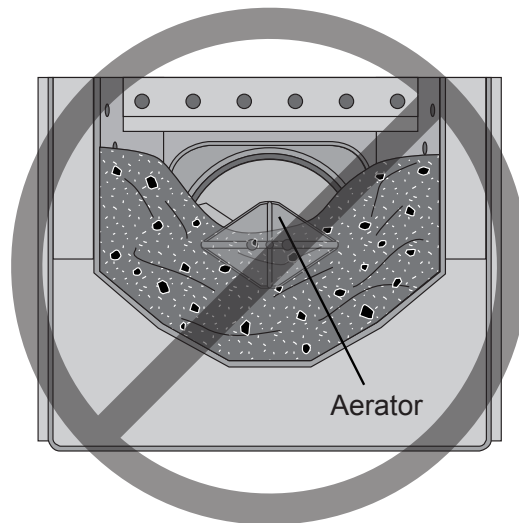

GENERAL INFORMATION

Make note of these precautionary statements, also found on the outdoor furnace.

⚠ DANGER

- Risk of fire or explosion - DO NOT burn garbage, gasoline, drain oil or other flammable liquids.
- If you smell gas: DO NOT light this appliance. Extinguish any open flames. DO NOT touch any electrical switch; DO NOT use a phone located in the building where the appliance is installed. Call your fuel supplier and follow their instructions.
- Risk of electrical shock - disconnect power before servicing unit.

MAINTENANCE SCHEDULE

DAILY
Check water level, inspect firebox and remove ash as needed.

WEEKLY
Inspect flues, aerator and burn chamber and clean as needed.

SEMI-MONTHLY
Twice a month during the heating season, inspect chimney and chimney transition and clean as needed.

MONTHLY
Inspect rope gaskets on the furnace door and chimney transition cover. Inspect chimney transition and clean as needed.

SEMI-ANNUALLY
Shut down and completely clean and inspect firebox, flues, chimney and burner assembly. Remove the tubing from the thermal valve; then clean the tubing and discharge tube by blowing air through it. Check the pH and nitrite levels of the water semiannually or if water is added, and add water treatment as necessary. **READ OWNER'S MANUAL FOR COMPLETE INSTRUCTIONS.**

⚠ WARNING

- Risk of fire - DO NOT store fuel or other combustible material within marked installation clearances.
- DO NOT install or operate this appliance before first reading and understanding the Owner's Manual.
- DO NOT allow others to install or operate this appliance without first reading and understanding the Owner's Manual.
- DO NOT leave this appliance unattended with firebox door unlatched.
- Avoid breathing smoke. Wear appropriate personal protective gear when servicing firebox or flues.
- DO NOT operate with flue draft exceeding -0.05 inches of water column.

⚠ CAUTION

- Hot surfaces.
- Keep face away from door area.
- DO NOT start fire until water level is full.
- Comply with all applicable state or local codes and regulations.
- Store ash in a covered non-combustible container.
- Take care when opening the door to prevent hot ash from spilling out.
- Keep children away from this appliance.
- Maximum draft marked on nameplate.

APPLIANCE LOCATION:

- When installing this appliance, consider the direction that smoke will travel with prevailing winds and chimney height.

⚠ CAUTION

Failure to perform proper care and maintenance will reduce the life and performance of your furnace. For best results, always follow these guidelines:

1. Add water treatment *before* filling with water.
2. Do not burn anything other than the recommended fuels.
3. Clean and inspect the furnace regularly.
4. Do not operate with the water temperature below 150°F (66°C).
5. Maintain the recommended water treatment levels at all times.
6. Clean the firebox thoroughly and keep it dry when not in use.
7. See Owner's Manual for more information about regularly scheduled maintenance.

⚠ CAUTION

CLEAN OUT THE LOWER AUGER BEFORE DISCONNECTING POWER.

To prevent the thermal valve from activating, turn off the Auto Re-light function and clean out the lower (burner) auger using the Clean Out Mode before disconnecting power.

To start Clean Out Mode, press the Auger button two times within one second. The Clean Out Mode light will turn on and only the lower (burner) auger will operate to empty all of the fuel from the lower (burner) auger. To empty the fuel faster, press and hold the Auger button while in Clean Out Mode until the lower (burner) auger is empty. After the lower (burner) auger is empty, clean the burn chamber.

NOTICE

Furnace must be leveled properly.

If the lower auger is not sloped down toward the front of the furnace, condensation can form in the lower auger tube and drip into the transition box.

NOTICE

To lock and unlock the FireStar controller, press the 'Water Temp' button, located on the controller, four times rapidly. When locked, the display on the controller will indicate 'LOC' for five seconds and any time a button on the controller is pressed.

NOTICE

Fuel door must operate properly.

It is important to check the fuel door (located behind this panel) monthly, to make sure it is operating properly.

NOTICE

After appliance has been installed, seal these holes with silicone to prevent rodents from entering.

NOTICE

DO NOT operate this appliance with this panel removed.

⚠ CAUTION

HOT GASES - Keep face away when viewing fire and from door area.

CAUTION

Do not plug, block or seal vent opening. Sealing can result in a dangerous buildup of pressure.

ATTENTION

Ne pas bloquer, obturer ou sceller l'ouverture du conduit d'évacuation. Sceller l'ouverture pourrait entraîner une augmentation dangereuse de la pression.

CAUTION

ANY TIME WATER IS ADDED the furnace **MUST BE** immediately heated to 185°F, circulated, and the inhibitor level tested. **FAILURE TO DO SO WILL RESULT IN DAMAGE** to your furnace's water jacket!

Carefully follow the steps in your Owner's Manual for adding water and testing inhibitor levels.

The Online Support Center at CentralBoiler.com allows you to access the Owner's Manual and view videos and other resources specific to your furnace.

CentralBoiler.com
Support

NOTICE

DO NOT alter this equipment in any way.

⚠ CAUTION

HOT Surfaces

DO NOT Touch During Operation

CAUTION

Smoke in the hopper is an indication that air flow through the furnace is restricted and may prevent proper furnace operation. If restricted air flow is suspected, inspect the following for obstructions or restrictions and clean if necessary:

1. Heat exchanger passageways.
2. Aerator - do not allow ashes in the burn chamber to accumulate over the aerator.
3. Chimney transition box/chimney.
4. Spark arrester (if present).

Refer to the Owner's Manual for more information.

NOTICE

Fuel door must operate properly.

It is important to check the fuel door regularly to make sure it is operating properly. When operating properly, the fuel door will be closed when the combustion fan is not operating.

CAUTION

For the furnace to operate optimally, air flow through the heat exchanger must be unrestricted. Failure to regularly care for and maintain the heat exchanger will reduce the life and performance of your furnace. Refer to the Owner's Manual for maintenance procedures and frequency.

WIRING DIAGRAM

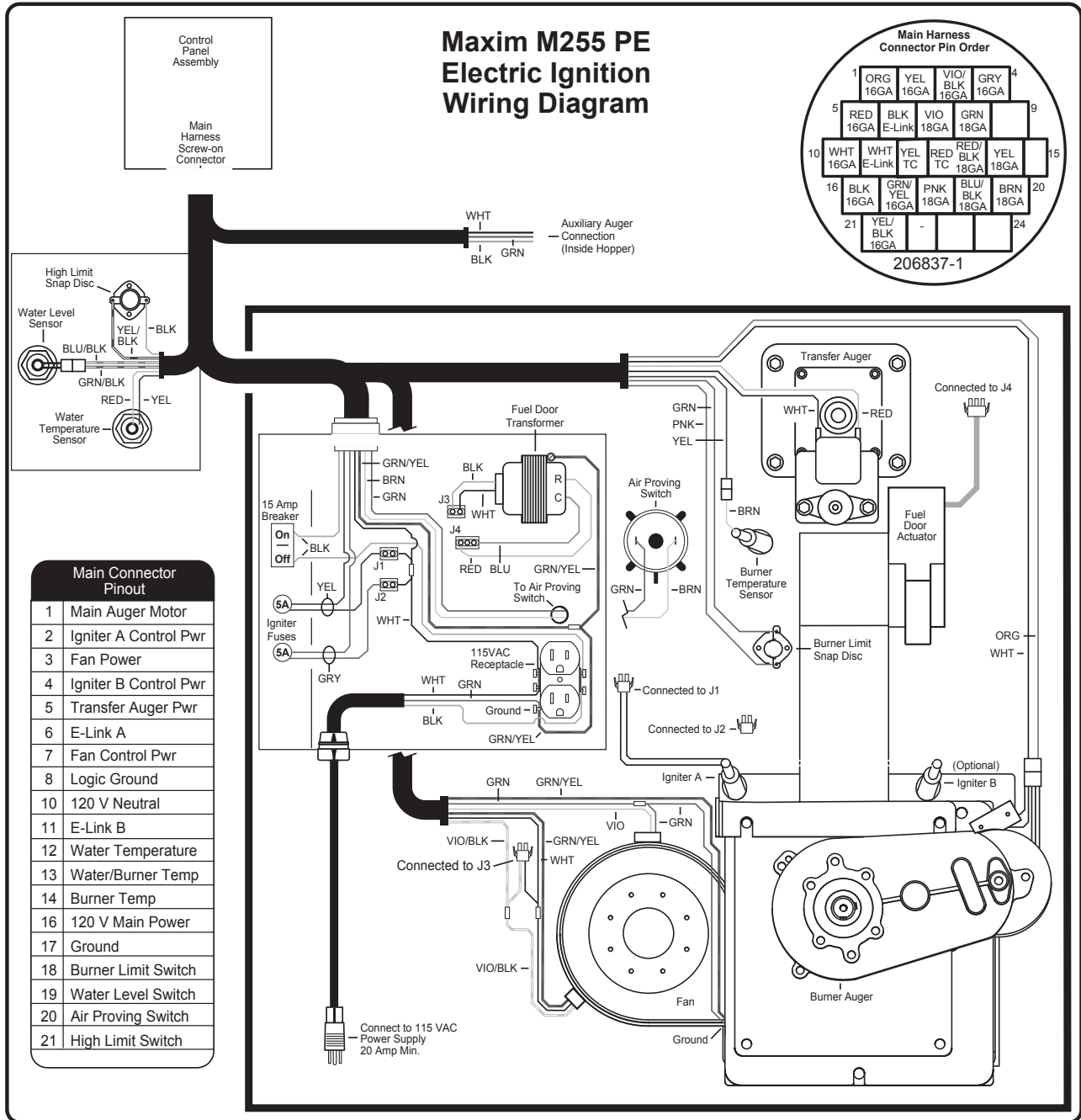

MAXIM LIMITED WARRANTY

WoodMaster, Inc. ("WoodMaster") warrants to the original owner, except (a) parts manufactured by others and excluded from warranty coverage below; and (b) parts or items specified below as covered by a limited one-year warranty, WoodMaster Maxim furnaces against defects in workmanship for a period of FIVE (5) YEARS from the date of original retail purchase, provided that the Limited Warranty Registration Form is completed and sent to WoodMaster within seven (7) days of the original owner taking possession of the furnace; otherwise this Limited Warranty shall be for a period of ONE (1) YEAR from the date of manufacture or one year from original retail purchase if proof of purchase date can be provided.

If a defect exists, at its option WoodMaster will (1) repair the defective part at no charge, using new or refurbished replacement parts, (2) exchange the furnace with a comparable model furnace that is new or which has been manufactured from new or serviceable used parts and is at least functionally equivalent to the original furnace, or (3) refund the purchase price of the furnace based on the pro-ration scale. A replacement furnace/part assumes the remaining warranty of the original furnace/part or ninety (90) days from the date of replacement or repair, whichever provides longer coverage for you. If a furnace or part is qualified for replacement under the provisions of this limited warranty, at WoodMaster's discretion, the furnace or part may be required to be returned to WoodMaster for inspection and recycling or disposal.

Parts Manufactured By Others. Parts that are factory-installed by WoodMaster, but are manufactured by others, may be covered by their own manufacturer's warranty and are not covered by this limited warranty, except the FireStar® controller is warranted against defects in workmanship for a period of two (2) years from the date of original retail purchase, provided that the Limited Warranty Registration Form is completed and sent to the WoodMaster within seven (7) days of the original owner taking possession of the furnace; otherwise, this limited warranty shall be good for a period of ONE (1) YEAR from the date of original retail purchase. This limited warranty covers the controller part only; service calls, mileage, and labor to diagnose the problem and install a new part are not covered.

Parts Covered by a Limited One Year Warranty. The following parts are covered by a limited warranty for workmanship defects for one year: aerator, burn chamber, thermocouple, hopper lid shock, chimney transition, firebox door parts, chimney box parts, paint, burner assembly, auger, auger motor and fan.

This Limited Warranty applies only to WoodMaster Maxim outdoor furnaces. This limited warranty covers only those defects that arise as a result of normal use of the outdoor furnace and does not cover any other defects or problems, including those that arise as a result of: (a) improper maintenance (b) operation outside the furnace's specifications (see owner's manual), accident, abuse, misuse, misapplication, or parts that are not factory-installed; (c) service performed by anyone other than WoodMaster unless authorized by WoodMaster in writing; (d) modifications undertaken without the written permission of WoodMaster; or (e) if any WoodMaster serial number has been removed or defaced. This warranty is void if the owner (fails to maintain the proper amount of corrosion inhibitor in the systems or) burns materials in the firebox other than premium-grade wood pellets.* This warranty excludes the cost of shipping, labor to remove or reinstall the furnace, plumbing labor and/or parts and the cost of alternative heat if the furnace is out of service for repairs. Warranty excludes replacement of water, inhibitors or other additives, and parts used in the system whether or not mounted on the furnace, such as pumps, valves, and piping.

WoodMaster is not liable for damage or repairs required as a consequence of faulty installations or applications by others or any event of force majeure. WoodMaster is not liable for incidents or accidents which can be prevented by the owner or that occur from the operation of the outdoor furnace. A backup heating system must be in place to prevent damage in case of failure to refuel the outdoor furnace or mechanical failure of the outdoor furnace or system occurs. Heat replacement representations found in WoodMaster promotional information should be used only as a guideline. Heat loss for all applications with all weather extremes and other heat variables must be considered when sizing an outdoor furnace for different applications.

THIS WARRANTY AND REMEDIES SET FORTH ABOVE ARE EXCLUSIVE AND IN LIEU OF ALL OTHER WARRANTIES, REMEDIES AND CONDITIONS, WHETHER ORAL OR WRITTEN, EXPRESS OR IMPLIED. WOODMASTER SPECIFICALLY DISCLAIMS ANY AND ALL IMPLIED WARRANTIES, INCLUDING, WITHOUT LIMITATION, WARRANTIES OF MERCHANTABILITY AND FITNESS FOR A PARTICULAR PURPOSE. IF WOODMASTER CANNOT LAWFULLY DISCLAIM IMPLIED WARRANTIES UNDER THIS LIMITED WARRANTY, ALL SUCH WARRANTIES, INCLUDING WARRANTIES OF MERCHANTABILITY AND FITNESS FOR A PARTICULAR PURPOSE ARE LIMITED IN DURATION TO THE DURATION OF THIS WARRANTY. No WoodMaster dealer or employee is authorized to make any modification, extension, or addition to this warranty. WOODMASTER IS NOT RESPONSIBLE FOR DIRECT, SPECIAL, INCIDENTAL OR CONSEQUENTIAL DAMAGES RESULTING FROM ANY BREACH OF WARRANTY OR CONDITION, OR UNDER ANY OTHER LEGAL THEORY. Some states and provinces do not allow the exclusion or limitation of incidental or consequential damages or exclusions or limitations on the duration of implied warranties or conditions, so the above limitations or exclusions may not apply to you. This warranty gives you specific legal rights, and you may also have other rights that vary by state or province.

*This voiding of warranty is required under the federal New Source Performance Standards for New Residential Hydronic Heaters and Forced Air Furnaces (40 CFR Part 60, Subpart QQQQ) and applies only if burning wood pellets mixed with other fuels for residential applications. Warranty disclaimer does not apply to devices using fuels other than wood pellets or units used solely for non-residential purposes (e.g., commercial or industrial purposes) that otherwise are operated in accordance with the Owner's Manual.

To obtain warranty service, contact the WoodMaster dealer from whom you purchased your furnace or contact WoodMaster by telephone (800-932-3629) or mail (600 Polk Ave. SW, Red Lake Falls, MN 56750). Please provide the dealer's name, original date of sale, model number and serial number in all communications. WoodMaster reserves the right to require the warranty service to be performed at WoodMaster facility when deemed necessary by WoodMaster.