

NOTE

When using a universal flow check valve (3 ports, FIP) a plug must be used to seal the unused port.

Radiant Heat (with Flow Check Valve)

NOTE

ON / OFF switch must be in the "ON" position for this install.

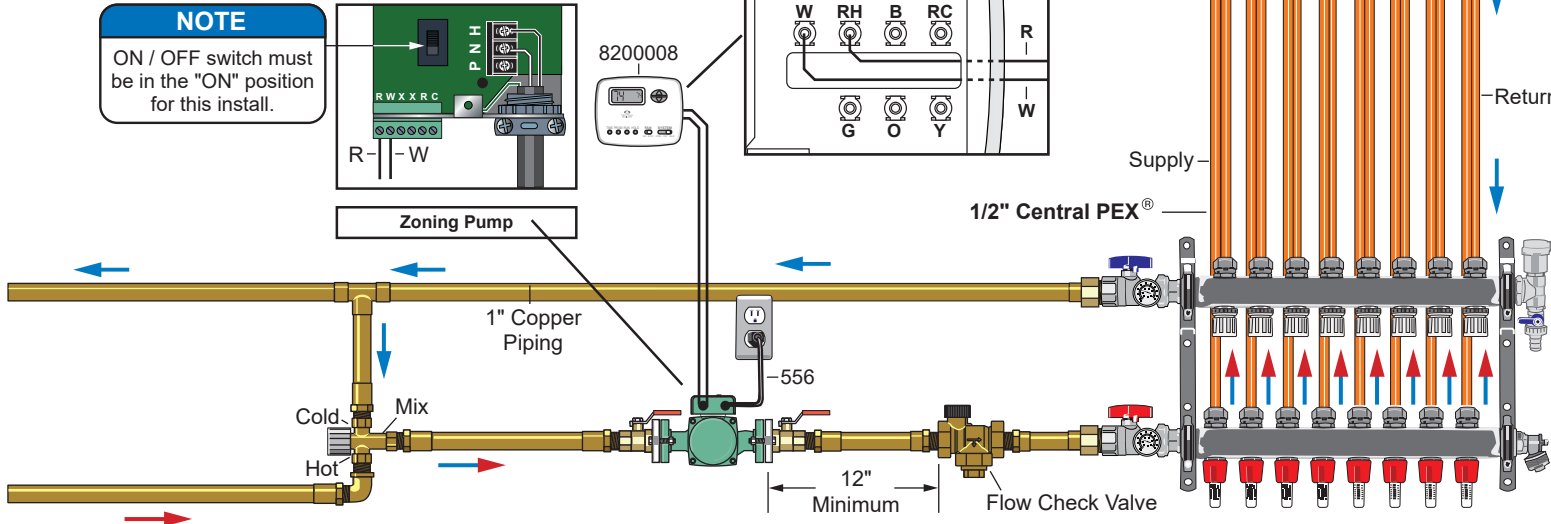

NOTE

If heating loops are above manifolds, additional controls (e.g. zone valve or flow check) may be needed to prevent ghost flow.

Flow Check Valve

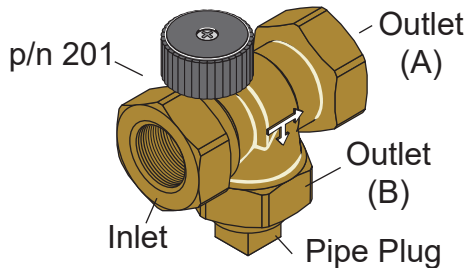

Flow Check Valve

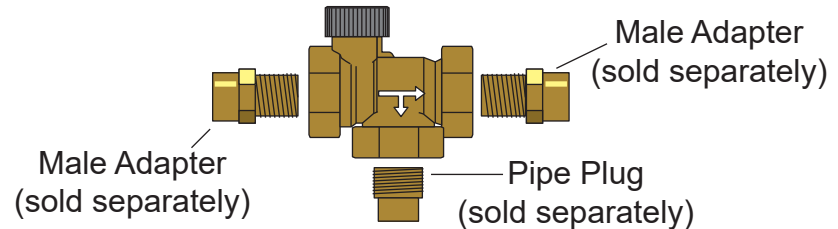

The flow check valve will open automatically when the pump starts to circulate the water. When the room thermostat reaches the set temperature and the pump shuts off, the flow check will close immediately preventing gravity circulation or "ghost flow." "Ghost flow" is caused by hot water rising and cold water sinking. Hot water rises in the vertical supply PEX pipes and cold water sinks in the vertical return PEX pipes. In systems with multiple zones, "ghost flow" usually occurs if a flow check or zone valve is not installed. A minimum of 12 inches of space between the pump and flow check valve is required for proper operation. Installing a flow check valve can increase the restriction in the line. The flow check valve must be disassembled (sweat only) prior to installation, as to not damage the internal components. Flow check valves are not needed when pipes (loops) are below the manifolds.

